

GO ANYWHERE



MAGNUM 1000 SERIES

TOP OF ITS CLASS



MAGNUM XF 1000 LE

UPGRADE YOUR WORKHORSE

It's time to take a step back, weigh your options, and come out on top. The ARGO® Magnum™ XF 1000 LE is chasing the title you deserve: Best-in-Class! At ARGO, we combine function and fun with our premium side-by-sides. Power and dependability start with the 997cc V-Twin SOHC EFI 4-stroke engine featuring engine braking and passes through an automatic CV transmission with Electronic Drive Belt Detection.

The class leading rear cargo box is up for the challenge to transport heavy equipment and material while you enjoy the industry's best-in-class cab space and on-board storage. The Magnum XF 1000 LE includes: Selectable Turf Mode/2WD/4WD, Tri-Mode EPS, aluminum wheels, roof, heavy-duty front bumper and a 4,500 lb. winch.

MAGNUM XF 1000 LE HIGHLIGHTS

- 997cc V-Twin EFI Liquid-Cooled 4-Stroke Engine
- Automatic CVT with Engine Braking
- Speed Keys
- Tri-Mode Electric Power Steering (EPS)
- Selectable Turf/Turf Assist/2WD/4WD and 4WD Lock Modes
- 14" Aluminum Alloy Black and Polished Wheels
- 27" 6-Ply Maxxis Big Horn Tires
- Front and Rear Hydraulic Disc Brakes
- Double A-Arm Front Suspension with 11" Travel
- Double A-Arm Rear Suspension with 11" Travel and Sway Bar
- 14.2" Ground Clearance
- 2" Receiver Hitch
- 2,500 lb. Towing Capacity
- 1,000 lb. Rear Cargo Capacity Box with Tilt-Assist Shock
- Premium Painted Plastic Body Panels
- Industry-Leading Cab Leg Room
- Tilt Steering Wheel
- Full Color Display
- Bench Seating and Headrests for three
- Adjustable Driver's Seat
- Rear View Mirror
- 3-Point Seatbelts with Anti-Cinch
- Multiple Dash and Underseat Storage Areas
- Full Length Skid Plate
- Poly Sport Roof
- Heavy-Duty Front Bumper
- 4,500 lb. Winch with Synthetic Rope

ACCESSORIES

- Front Windshield with Wiper
- Rear Window
- Heater and Ventilation
- Plow Kit
- Full Doors
- Side Mirrors



CAB

Best-in-class cab space, period. Pair this open cockpit with a certified ROPS, adjustable sliding driver's seat, 3-point seatbelts with anti-cinch and individual headrests for three and you get one of the most comfortable and confidence inspiring side-by-sides on the market!



LARGE CAPACITY CARGO BOX

Leading the pack with best-in-class cargo space, this utility cargo box touts a plethora of resourceful features including: 1,000 lb load capacity, 47-degree dump angle, tilt assist shock, D-ring anchor points and stake sides.



HIGH-CAPACITY STORAGE

More storage compartments than you know what to do with. Enjoy the easy-access design of the dual glovebox, spacious under-seat stowage, fold-down center counsel with cup holders, and in dash receptacle with cupholders.



TRI-MODE EPS

Conveniently set from the digital display, the Tri-Mode Electric Power Steering allows the rider to select no assist, minimum assist or maximum assist steering providing the driver optimal control and effort.



SUSPENSION

Featuring a long travel independent double A-arm front and rear suspension touting 11" of travel for optimal comfort and control in all riding conditions.



SPEED KEYS

Maximum usage without the speed. The speed key system utilizes two different ignition speed keys. One that limits the max speed to 25 MPH (40 km/h) and one that opens up the full potential.

SELECTABLE FRONT & REAR DIFFERENTIAL

Take control of any situation with five different traction modes. The electronic selectable front and rear differential exceeds expectation by not only delivering 2WD, 4WD and 4WD Lock, but also adds in Turf Mode delivering power to one rear wheel and Turf Mode Assist which directs power to one rear wheel and one front wheel for that added assist when trying to tread lightly.

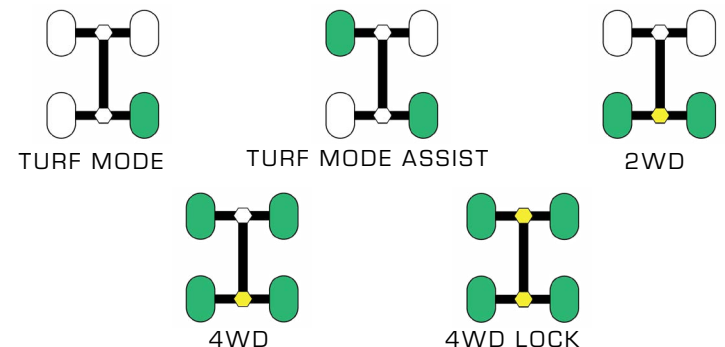

MAGNUM XF 1000 LE

DISPLACEMENT	997CC
ENGINE STROKE	4-STROKE
CYLINDER ARRANGEMENT	SOHC V-TWIN CYLINDER
VALVE CONFIGURATION	4 VALVE
FUEL SYSTEM	EFI
COOLING SYSTEM	LIQUID
START METHOD	ELECTRIC START
IGNITION	ECU
TRANSMISSION TYPE	CVT AUTOMATIC
FINAL DRIVE	SHAFT DRIVE
DIFFERENTIAL FUNCTION	SELECTABLE FRONT & REAR
DRIVE SYSTEM TYPE	TURF/TURF ASSIST/2WD/4WD/4WD LOCK
ELECTRIC DIFFERENTIAL LOCK	YES
GEAR SELECTION	H/L/N/R/P
REVERSE	YES
ENGINE BRAKING SYSTEM (EBS)	STANDARD
LENGTH	122 IN (3100 MM)
WIDTH	64.0 IN (1625 MM)
HEIGHT	78.7 IN (2000 MM)
SEAT HEIGHT	37.3 IN (946 MM)
GROUND CLEARANCE	14.2 IN (360 MM)
WHEELBASE	83.5 IN (2120 MM)
TOWING CAPACITY	2,500 LBS (1 134 KG)
DRY WEIGHT	1,642 LBS (745 KG)
WET WEIGHT	1,714 LBS (778 KG)
FUEL TANK CAPACITY	11.09 GAL (42 L)
RIDER CAPACITY	3
SUSPENSION - FRONT/REAR	INDEPENDENT DOUBLE A-ARM
SUSPENSION TRAVEL - FRONT	11 IN (27.9 CM)
SUSPENSION TRAVEL - REAR	11 IN (27.9 CM) WITH SWAY BAR
BRAKE - FRONT/REAR	HYDRAULIC DISC
TIRE SIZE FRONT/REAR	27 x 9-14/ 27 x 11-14
WHEEL RIM	ALUMINUM
ELECTRIC POWER STEERING	TRI - MODE EPS
HITCH	2" STANDARD RECEIVER
FRONT BUMPER	HD STANDARD

WINCH	4,500 LB WITH SYNTHETIC ROPE
SKID PLATE	PLASTIC
REAR BOX STORAGE	1,000 LB (454 KG)
REAR BOX DIMENSIONS (INNER)	42.5 x 63 x 12.6 IN (1080 x 1600 x 320 MM)
CARGO BOX LIFT	MANUAL WITH SHOCK ASSIST
STORAGE	DUAL GLOVE BOX, DASH, ARM REST, UNDERSEAT
PASSENGER HANDLES	STANDARD
PASSENGER BACKREST	STANDARD
REAR VIEW MIRROR	STANDARD
ROOF	YES
12V CHARGER	STANDARD
LIGHTING	DUAL LED HIGH/LOW BEAM, LED TAIL LIGHT
INSTRUMENTATION	DIGITAL INSTRUMENT PANEL
COLOR	GRAPHITE GREY METALLIC with ORANGE



GO
ANYWHERE™

ARGOxtv.com

Some vehicle applications shown are for demonstration purposes, originating from third parties and not available from ARGO®. In all cases vehicle load limits have been considered. Never overload your ARGO vehicle. Always remain seated while in your ARGO vehicle. ARGO vehicles can be hazardous to operate. Improper use can cause severe injury or death. Riders must wear an approved helmet, eye protection, and protective clothing. Use handholds and stay completely inside the vehicle. Each rider must read and understand the operator's manual before riding. Follow all instructions and warnings. Avoid abrupt maneuvers, paved surfaces, hard acceleration when turning, and side hilling: slow down before entering a turn. Never engage in stunt driving. Avoid excessive speeds and be particularly careful on difficult terrain. Magnum Series models are for users over 16 years old only. Never operate on public roads. ARGO vehicles are designated for off-highway use only — collisions with cars and trucks can occur. Never drive or ride under the influence of alcohol or drugs. Do not shoot from or lean firearms or bows against ARGO vehicles. ARGO recommends that all riders take an approved ATV or UTV training course. For safety or training information in the U.S., call the ATV Safety Institute at (800) 887-2887. In Canada, please contact the Canada Safety Council at (613) 739-1535 or see your dealer. Along with concerned conservationists everywhere, ARGO urges you to respect public and private lands. Ride only on designated areas or trails. Preserve your future riding opportunities by showing respect for the environment, local laws and the rights of others when riding. All materials and specifications are subject to change without notice. All specifications, claims and information contained within are based on current knowledge and readily available as printed material as of May 2024. ARGO, Frontier, Aurora, Conquest, Magnum, and XTV are trademarks of Ontario Drive and Gear Limited.