



2025 OPERATOR'S MANUAL



**Xplorer XR 500
Xplorer XR 500 SE**

***This vehicle is not a toy. Never allow anyone under
16 years of age to operate this ATV.***

Part #: 085-3618

Effective Date 6/2024

NOTE

Read this manual before you operate your ARGO ATV. It contains safe operating instructions and warns the user about potential hazards that can result in personal injury.

Warnings are identified in the text by the following symbol:



WARNING

Warning text warns the user about potential hazards that can result in personal injury or death.

Cautions are identified in the text by the following symbol:



CAUTION

Caution text contains cautions that can prevent damage to the ATV.

This manual is based on the latest product information available at the time of printing. ARGO reserves the right to make changes at any time and without obligation.

Reproduction of any part of this publication is prohibited without prior written permission.

© 2024 ARGO



WARNING

CALIFORNIA PROPOSITION 65

WARNING: This product may contain fuels, oils and fluids, battery posts, terminals and related accessories which contain lead and lead compounds and other chemicals identified by the State of California to potentially cause cancer, birth defects, and other reproductive harm. These chemicals are found in vehicles, vehicle parts and accessories, both new and replacements. During maintenance, these vehicles generate used oil, waste fluids, grease, fumes and particulates, all identified by the State of California to potentially cause cancer, birth defects, and other reproductive harm.

For more information go to:

www.P65Warnings.ca.gov

PREFACE

This manual describes the controls, operation and basic maintenance procedures for the ARGO ATV from date of printing. Please take the time to read this manual carefully, for your safety and that of others. By following these instructions, you will ensure extended, trouble free operation of your ATV.

Before you drive your ARGO ATV, make sure you understand how to use all controls, particularly the brakes and steering system. Learn how to drive your ATV in an open level area, away from buildings, trees and other obstacles, until you are completely familiar with its operating characteristics. Drive very slowly until your driving skills improve, and drive with caution and consideration at all times. The risk of accident or injury is greatest during the first weeks of use. Take special care during this period. ALWAYS RESPECT OUR ENVIRONMENT.

CAUTION TO THE ARGO OWNER/OPERATOR:

Before you operate your new ATV, we highly recommend these important points:

- Read your Operator's Manual.
- Never allow anyone under 16 years of age to operate this ATV.
- Take the training course before operating your ATV, ask your dealer for more information.
- This ATV is designed for one person only.
- This Operator's Manual is provided to make the operator aware of proper operating procedures. It also includes useful information related to general care and maintenance of your ATV.
- Prior to any ATV operation, it is absolutely essential to read and comprehend each section in this manual as well as watch the safety video provided with your ATV to develop an understanding of your ATV and to ensure your safety. After reviewing this manual and watching the safety video, store them in a dry and easily accessible place for future reference.
- This manual is designed to help familiarize you with safety, assembly and operation. Read this manual and follow the recommendations to help ensure safe and efficient operation.
- The information contained within this manual was current at the time of printing. Constant improvement in the design and quality of components may result in discrepancies between the actual ATV and information presented in this manual.
- To view the most up-to-date manuals or to order a replacement Operator's Manual, please contact an authorized dealer or visit the ARGO website.
- This manual has been prepared to instruct you in the safe and responsible operation of your ATV. Read and abide by all safety alert information about this ATV. If you do not understand any part of this manual, contact your local dealer for additional information and clarification. As the operator of this ATV, you are in complete control. Only you can prevent an accident from happening.
- Right-hand and left-hand, as used in this manual, are determined when properly seated on the vehicle.
- Never modify the vehicle in any way that will alter the weight distribution of the vehicle, decrease its stability or increase the speed beyond the factory specifications. Such modifications can cause serious personal injury or death. The manufacturer prohibits and disclaims responsibility for any such modifications or any other alteration which would adversely affect the safety of the vehicle. The vehicle manufacturer reserves the right to incorporate engineering and design changes to products in this manual, without obligation to include these changes on units sold previously. The information contained in this manual may be revised periodically by the manufacturer, and therefore is subject to change without notice.

TABLE OF CONTENTS

SECTION 1 - Introduction

Introduction	1
Getting Acquainted With Your ATV	4

SECTION 2 - Safety Information

Safety Information	7
Warnings	12
Hangtags and Warning Labels	21

SECTION 3 - Specifications

Specifications	25
----------------------	----

SECTION 4 - Description and Identification

Identification Number Records	27
Location of Parts and Controls	28
Control Functions	
Ignition Switch	30
Handlebar Switches	30
Emergency Stop Switch	30
Headlight Switch	31
Starter Button	31
Reverse Override Switch	31
2WD / 4WD Selector Switch	32
Transmission Ranges	32
Brakes	33
Left Hand Brake Lever	33
Rear Brake Pedal	34
Throttle Lever	34
Speed Limiter	35
Gauge	36
Fuel Tank Cap	37
Seat Removal	37
Seat Installation	38
Safety Flag Bracket	38
Fuses	38
Electrical Output Terminals	38
Storage Compartment	39
Tool Kit	39

SECTION 5 - Getting to Know Your ATV

Getting to Know Your ATV	41
Before Riding	41
Rider Preparation - Age Recommendation	41
Pre-Operation Checks	41
Safe Riding Rules	41
Protective Apparel	41
Weight Limits	42
Accessories	42

No Modifications	42
For Off-Road Use Only	42
Environment	42
Weather	42
Terrain	43
Night Riding	43
Paved Surfaces	43
Trail Riding	43
Turning Your ATV	44
Leaning, Weight Shift, and Balance	44
Wide Turns	44
Sharp Turns	45
Quick Turns	45
K-Turns	46
Climbing Uphill	47
Riding Downhill	48
Crossing A Slope	48
Swerving	49
Riding Over Rough Terrain	49
Crossing Through Shallow Water	50
Sliding or Skidding	51
Crossing Roads	51
Cold Weather Operation	51
Braking	52
Reversing	52
Parking	53
Parking on a Hill or Slope	53
Stopping the Engine	54
Trailering and Towing	54
Transporting Your ATV	55
What To Do If	56

SECTION 6 - Before You Ride

Engine Break-In	57
Pre-Operation Checks	57
Pre-Operation Check Table	58
Front and Rear Brakes	59
Fuel	59
Engine Coolant Reservoir	60
Coolant Level Inspection	60
Engine Oil	61
Oil Level Inspection	61
Front Differential / Rear Drive	62
Throttle Lever	62
Fittings and Fasteners	62
Lights	62
Switches	62
Tires	63
How to Measure Tire Pressure	63
Tire Wear Limit	63

SECTION 7 - Operation

Mounting the ATV	65
Starting the Engine	65
Warming up the Engine	66
Braking / Stopping	66
Transmission Ranges	67
Parking	68
Dismounting the ATV	68

SECTION 8 - General Maintenance

General Maintenance	69
Maintenance Schedule	70
Radiator	71
Shock Absorbers	71
Engine Oil - Inspection	72
Engine Oil and Oil Filter Change	72
Front Gear Case Oil Inspection	74
Rear Gear Case Oil Inspection	74
Front / Rear Gear Case Oil (Inspection / Change	74
Brake Hoses	75
Hydraulic Brakes	75
Brake Fluid	76
Parking Brake Lock	76
Rear Foot Brake	77
Brake Pads	77
Protective Rubber Boots	78
Ball Joint Boots	78
Tie Rod Boots	78
Drive Axle Boots	79
Wheel Removal	80
Wheel Installation	80
Drive Select Lever Adjustment	80
Battery	81
Battery Capacity	81
Charging / Maintenance Charging	83
Jump Starting	83
Spark Plug	84
Throttle Cable Adjustment	84
Air Filter	85
Air Filter Housing Drain	86
Draining the V-Belt Cover	86
Tires	87
Tire Replacement	87
Muffler / Spark Arrester	88
Light Bulb Replacement	88
Headlight	89
Running Lights	89
Taillight / Brakelight	90
Checking / Adjusting Headlight Aim	90

Headlight Aim Adjuster 91
Fuses..... 91
Noise Regulation 92
Troubleshooting 93

SECTION 9 - Preparation For Storage

Preparation For Storage 95

SECTION 10 - Warranty

Limited Warranty 97
Emissions Warranty..... 99

Maintenance Record 101

SECTION 1

Introduction

ARGO welcomes you to its growing family of new product owners. This All-Terrain Vehicle (ATV) has been designed with care and built by skilled workers using quality materials.

Proper setup, maintenance and safe operating practices will help you get years of satisfactory use from this ATV.

Your safety and the safety of all ARGO users is of the greatest concern to us. You will find numerous safety statements in this manual. Please read and follow them carefully. Always be safety conscious when you operate your ARGO and remember it is a motorized vehicle.

Please take the time to develop your driving skills before attempting new challenges. Observe the recommendations outlined in this Operator's Manual and remember; some things are just impossible, even with an ARGO.

WELCOME TO THE WORLD WIDE ARGO FAMILY!



Introduction

Thank you for choosing this quality ARGO ATV. It has been designed and manufactured to provide you with reliable and enjoyable operation. This Owner's Manual should be considered a permanent part of your ATV and must remain with the ATV in the event of a resale.

This manual was prepared to provide you with the information required to operate and maintain your ATV. This manual also covers rider-related instructions, as well as service and storage instructions. If your ATV ever requires repair or service, contact an authorized ARGO ATV dealer for professional service.

As the owner and rider of an ARGO ATV, you should become thoroughly familiar with your ATVs basic operation, maintenance and storage procedures. Please read and understand the entire Owner's Manual before operating your ARGO ATV to ensure safe and proper use. Always operate your ATV within your level of skill and current terrain conditions.

At the time of publication, all of the information and illustrations in this manual are technically correct. Some illustrations herein are used to best represent a certain procedure or item and are not intended to depict actual conditions. Because ARGO is constantly refining and improving its products, there may be differences between the vehicle images and the text depicted in this manual and your ATV. As such, no retroactive obligation to the product is available.

REPLACEMENT PARTS, ACCESSORIES and SERVICE

- Most replacement parts and accessories are typically available from your dealer. For immediate availability and convenience, it is recommended items be ordered from an authorized dealer. Take this manual and all supplements to the dealer when ordering parts in person.
- Orders may be subject to a minimum fee. A listing of authorized service providers in your area is also available on the website.
- Unapproved installation of parts or accessories can create a substantial safety hazard and increase the risk of personal injury.
- Use authorized parts only.

PLEASE TAKE A FEW MOMENTS TO GET ACQUAINTED WITH YOUR ATV BY READING THIS OWNER'S MANUAL

NOTE:

The manufacturer **DISCLAIMS LIABILITY FOR ERRORS IN THIS MANUAL**, and **SPECIFICALLY DISCLAIMS LIABILITY FOR INCIDENTAL AND CONSEQUENTIAL DAMAGES** resulting from the use of the information and material in this manual.

Name: _____

Address: _____

Telephone: _____

Purchase Date (mm/dd/yyyy): _____

Model: _____

Frame Number: _____

Engine Number: _____

Key Number: _____

- Before operating this ATV, the owner and each operator must understand that this ATV was not designed or manufactured to meet specifications for use on public roads, streets, highways or thoroughfares.
- The owner and operator(s) must read and understand all the instructions for proper assembly and safe operation, as well as the instructions concerning the engine and all other portions of the ATV, as described and illustrated in this manual.
- This ATV is **NOT** to be operated by anyone under 16 years of age.
- This ATV is **NOT** a toy.
- Be sure to follow the recommended maintenance schedule and service your ATV accordingly.

PREVENTATIVE MAINTENANCE IS EXTREMELY IMPORTANT TO THE SAFE OPERATION AND LONGEVITY OF YOUR ATV

We advise you to follow the recommended maintenance program as outlined in this manual. This program is designed to ensure all critical components on this ATV are thoroughly inspected at specified intervals.

Precautionary Measures

Protect Your Sport

- Know all State and local laws relating to ATV riding,
- Respect your ATV
- Respect the environment, and
- You will gain the respect of other fellow riders.

GETTING ACQUAINTED WITH YOUR ATV

This manual will provide you with a good basic understanding of the features and operation of this ATV. This manual includes important safety information. It provides information about special techniques and skills necessary to ride the ATV. It also includes basic maintenance and inspection procedures. If you have any questions regarding the operation or maintenance of your ATV, please consult dealer.

IMPORTANT SAFETY MESSAGE:

- The Consumer Product Safety Commission has concluded that ALL-TERRAIN VEHICLES (ATVs) may present a risk of DEATH or SEVERE INJURY in certain circumstances. While accidents may occur for many reasons:
 - As of September, 2022 the year 2019 is the most recent year of reporting for fatalities that CPSC considers complete. CPSC is aware of 1,513 people, including many children, have died in accidents associated with ATVs during a 3-year period from 2017 through 2019.
 - Many people have become severely paralyzed or suffered severe internal injuries as a result of accidents associated with ATVs.
 - Every month, thousands of people are treated in hospital emergency rooms for injuries received while riding an ATV.
 - **You should be aware that AN ATV IS NOT A TOY AND CAN BE HAZARDOUS TO OPERATE.** An ATV handles differently from other vehicles, including motorcycles and cars. A collision or rollover can occur quickly, even during routine maneuvers such as turning and driving on hills and over obstacles, if you fail to take proper precautions.
 - Read this manual carefully and completely before operating your ATV. Make sure you understand all instructions.
 - For Type 1 ATVs, Category G (General Use) ATV. An ATV intended for recreational and/or utility use by an operator age 16 or older.
 - Pay attention to the warning and notice labels on the ATV.
 - Never operate an ATV without proper training or instruction. For a training course, please consult a dealer or visit argoxtv.com for a link to RIDER SAFETY.
 - This ATV is designed for a single rider, do not carry a passenger.
 - This ATV is designed exclusively for off-road use. It is not designed, properly equipped or licensed to be safely operated on public streets and highways.
 - This ATV complies with all applicable off-road noise level and spark arrester laws and regulations in effect at the time of manufacture.
 - Please check your local riding laws and regulations before operating this ATV.
 - For your safety, follow and understand all CAUTIONS, WARNINGS and LABELS contained in this Operator's Manual.
 - For your safety, watch the safety video provided with your ATV.
 - Keep this Operator's Manual with your ATV at all times for reference.
- FAILURE TO FOLLOW THE WARNINGS and CAUTIONS CONTAINED IN THIS MANUAL CAN RESULT IN SERIOUS INJURY OR DEATH.**

IMPORTANT

Operate this ATV with safety constantly in mind. Off-road vehicles face unpredictable and often hazardous terrain conditions. It is ultimately the operator's responsibility to handle the ATV safely within its limitations and to decide when and where to travel.

FOR MORE INFORMATION ON OUR FULL PRODUCT OFFERING, VISIT OUR WEBSITE www.argoxtv.com

- For a detailed description of warranty coverage for your ATV, refer to the Warranty section found in this Owner's Manual or visit our website.
- For a detailed description of the emissions warranty for your ATV, refer to the Emissions Warranty section of this Owner's Manual or visit our website.

ARGO WANTS YOU TO BE SATISFIED WITH YOUR NEW ATV. IF YOU DO NOT UNDERSTAND ANY PART OF THIS MANUAL OR ARE NOT SATISFIED WITH THE SERVICE RECEIVED, PLEASE TAKE THE FOLLOWING ACTIONS:

Discuss the matter with your dealership service manager. Make sure they are aware of any problems so they can assist you.



WARNING

All engine exhaust contains carbon monoxide, a deadly gas. Carbon Monoxide is a colorless, odorless, tasteless gas, which may be present even if you do not see or smell any engine exhaust.

Avoid Carbon Monoxide Poisoning.

- Do not run engine indoors. Even if you try to ventilate engine exhaust with fans or open windows and doors, carbon monoxide can rapidly reach dangerous levels.
- Do not run engine in poorly ventilated or partially enclosed areas such as barns, garages or carports.
- Do not run engine outdoors where engine exhaust can be drawn into a building through opening such as windows and doors.

SECTION 2

Safety Information

An ATV is NOT a Toy and Can Be Hazardous To Operate

An ATV handles differently from other vehicles such as motorcycles and cars. A collision or rollover can occur quickly, even during routine operation such as turning, driving over obstacles, on hills or rough terrain, if you do not take necessary precautions.

SEVERE INJURY OR DEATH can result if you do not follow these instructions:

- Read this manual and all CAUTION/WARNING labels carefully and follow the operating procedures described.
- Never operate an ATV without proper instruction. Take a training course. Beginners should receive training from a certified instructor. Contact the ATV Safety Institute at: U.S. - 1-800-887-2887 or Canada - 1-613-739-1535 to find out about a training course nearest you. Visit www.atvsafety.org to register for free ATV safety training. ARGO is offering a \$100 incentive for completion of the ASI approved safety training.
- * FOR MORE INFORMATION ABOUT ATV SAFETY in the United States, call the Consumer Product Safety Commission at 1-800-638-2772 or visit www.cpsc.gov or visit www.atvsafety.org.
- Never allow anyone under 16 years of age to operate this ATV.
- Never carry a passenger.
- Never permit a guest to operate this ATV unless the guest has read this manual and all product labels and has completed the training course.
- Never operate an ATV on any paved surfaces, including sidewalks, driveways, parking lots, and streets.
- Never operate this ATV on any public street, highway, or road (dirt or gravel).
- Never operate an ATV without wearing an approved helmet that fits properly. You should also wear eye protection (goggles or face shield), gloves, boots, long-sleeved shirt or jacket, and long pants.
- Never consume alcohol or drugs before or while operating this ATV.
- Never operate at excessive speeds. Always travel at a speed which is proper for the terrain, visibility and operating conditions, and your experience.
- Never attempt wheelies, jumps, or other stunts.
- Always inspect this ATV each time you use it to make sure it is in safe operating condition. Always follow the inspection, maintenance procedures and schedules described in this manual.
- Always keep both hands on the handlebars and both feet on the footrests of the ATV during operation.
- Always go slow and use caution when operating on unfamiliar terrain. Always be alert to changing terrain conditions when operating the ATV.
- Never operate the ATV on hills too steep for the abilities of the operator or the ATV. Practice on smaller hills before attempting larger hills.
- Never operate on excessively rough, slippery, or loose terrain.
- Always follow proper procedures for turning as described in this manual. Practice turning at slow speeds before attempting to turn at faster speeds. Do not turn at excessive speed.
- Always have the ATV inspected by an authorized ARGO dealer if it has been involved in any type of accident.
- NEVER OPERATE UP OR DOWN HILLS STEEPER THAN 25 DEGREES.

An ATV is NOT a Toy and Can Be Hazardous To Operate

- Always follow proper procedures for climbing hills as described in this manual. Check the terrain carefully before you start up any hill. Never climb hills with slippery or loose surfaces. Shift your weight forward. Never accelerate suddenly. Never go over the top of any hill at a high rate of speed.
- Always follow proper procedures for going down hills and for braking on hills as described in this manual. Check the terrain carefully before you start down any hill. Shift your weight towards the back of the ATV. Never go down a hill at a high rate of speed. Avoid going down a hill at an angle which would cause the ATV to lean sharply to one side. Go straight down the hill whenever possible.
- Always follow proper procedures for crossing the side of a hill as described in this manual. Avoid hills with slippery or loose surfaces. Shift your weight to the uphill side of the ATV. Never attempt to turn the ATV around on any hill until you have mastered the turning techniques described in this manual on level ground. Avoid crossing the side of a steep hill if possible.
- Always use proper procedures if you stall or roll backward when climbing a hill. To avoid stalling, maintain a steady speed when climbing a hill. If you stall or roll backwards, follow the special instructions for braking described in this manual. Dismount the ATV on the uphill side or to either side if pointed straight uphill. Turn the ATV around and mount the ATV following the special instructions described in this manual.
- Always check for obstacles before operating in a new area.
- Never attempt to operate over large obstacles, such as large rocks or fallen trees. Always follow proper procedures when operating over obstacles as described in this manual.
- Always use caution when skidding or sliding. On slippery surfaces, such as ice, go slow and be very cautious in order to reduce the chance of skidding or sliding out of control.
- Never operate an ATV in fast flowing water or in water deeper than the footrests. Remember that wet brakes may have reduced stopping capability. Test your brakes after exiting any water. If necessary, apply the brake lightly several times to let friction dry out the pads.
- Always use the size and type of tires specified in this manual.
- Always maintain proper tire pressure as described in this manual.
- Never improperly install or improperly use accessories on your ATV.
- Never exceed the stated load capacity for this ATV.

An ATV is NOT a Toy and Can Be Hazardous To Operate

IMPORTANT MESSAGE

Your safety is very important to ARGO. That is why we urge you to read this message before you operate this ATV. Off-road riding can be fun. However, an ATV is not a toy and it can be hazardous to operate. As with any activity involving speed and skill such as bicycling or skateboarding, poor judgment can result in injuries and we don't want that to happen! You can help prevent accidents by making good decisions about if, when, and how you ride this ATV.

Evaluate Riding Readiness

The first decision you'll need to make is whether you're ready to ride. Riding readiness varies widely from one person to another, and while the minimum age for this ATV is 16 years of age, there are other factors that you should consider.

Physical size and ability are important considerations. To help determine whether a rider is big enough for this ATV, stand up on the footboards and grasp the hand grips. While holding this position, ensure you have at least three inches (8cm) of clearance between the ATV seat and the rider's "seat of the pants". At least three inches (8cm) of clearance is needed so you can stand up for balance and comfort, and to shift your body forward, backward and from side to side.

Also make sure you can comfortably reach and operate all the controls. For example, can you turn the handlebars all the way to the right and left? Can you operate the throttle and brake levers while holding onto the hand grips? If not, you are not physically ready to ride this ATV.

Before you operate an ATV, decide whether you are physically, mentally and emotionally ready to ride.



Patience And Practice

Even if you take a certified training course, it's up to you to ensure your safety. Remember, learning to ride a ATV is a gradual step-by-step process. It takes time, patience and practice.

To help you regulate your rate of learning, your ATV was delivered with an **adjustable throttle limiter**. The limiter may be adjusted to reduce the maximum speed of the ATV. For adjustment instructions, see page 29.

Personal Choices

A safe, enjoyable ATV ride is dependent on many personal choices. An ATV, like all motorized vehicles, can be dangerous to operate if you choose to ignore safety precautions, take unnecessary chances, or ride beyond your ability or your ATV's capability. Don't allow the thrill of freedom or adventure to affect your ability to make good, safe choices.

An ATV is NOT a Toy and Can Be Hazardous To Operate

Always Supervise Inexperienced Riders

Supervision is another important obligation of the owner. Even after riders become skilled off-road riders, it also helps to regularly remind all riders to follow the instructions and warnings in this manual. And remember, it's the owner's responsibility to see that the ATV is properly maintained and kept in safe operating condition.

If you choose to lend your ATV to another rider, make sure the rider is 16 years old or older and has completed the safety training course. You should understand that the decision to lend the ATV is yours.

Use the below safety gear before operation:

Clothing and Gear

While riding your ATV, you will find it important to dress correctly to prevent personal injury. Below is the minimum protection recommended to wear during every ride:

1. Helmet
2. Eye Protection
3. Long Pants
4. Long Sleeve Shirt
5. Gloves
6. Boots/Ankle Protection

Helmet

There are many different types and styles of helmet to choose from today. Be sure to choose a helmet that complies with the current standards of the U.S. Department of Transportation (DOT), The Snell Memorial Foundation, or the American National Standards Institute (ANSI). Helmets that comply with one or more of the above standards have a defined label located on the inside or outside of the helmet.

These helmets should provide full-face protection.

If you damage your helmet, obtain a new one immediately.

Remember: Your helmet is not providing any safety if the chin strap is not securely fastened.

Eye Protection

Wear eye protection, such as goggles, to completely surround your eyes to prevent any dirt or other items from getting into your eyes. Sunglasses are not a form of protection as they are open on the sides.

Long Pants and Long Sleeve Shirt

Protection from sticks, branches, long grass, airborne objects, or anything that could possibly scrape your skin. The heavier the material, the better the protection.

Gloves

Gloves will provide protection to your hands from any debris or incimate weather. Choose a glove that provides a gripping surface as well as protection.

An ATV is NOT a Toy and Can Be Hazardous To Operate

Boots/Ankle Protection

Choose a boot that protects the largest possible of your leg (preferable up to your knee) and can handle impact of rocks, dirt or branches. Choose a boot that has low heel and a good tread will help prevent your feet from slipping off the footrests in wet or rugged conditions.

First Aid and Survival

Prepare for the unexpected. Emergencies and accidents happen and are ever worse when you are not prepared for them. Below is a recommended list of items you should have before every ride:

1. Tools

Routine maintenance will generally eliminate the need for emergency repairs during your ride. Riding on rough terrain could cause some fasteners to loosen. Carrying the right tools can prevent down time. Below is a recommended list of tools to carry on your ride:

- a. Spark plug
- b. Spare parts
- c. Rope
- d. Tool kit
- e. Duct tape
- f. Headlight/Taillight bulbs

2. Water

Water is an important part of your ride regardless of the duration. Heat exhaustion and heat stroke can suddenly shorten your ride. If you become dehydrated, you may find yourself unable to safely operate your ATV.

3. Identification

If something happens to you while operating your ATV, emergency personnel will need to know who you are and who to call in the event of an emergency. It may be possible, you are unable to provide that information due to injury. Put identification in your pocket before you ride.

4. First Aid Kit/ Emergency Kit with Flashlight

Several items are recommended in your Emergency Kit including a *Flashlight*; *Matches* in the event you need to start a fire; *Flares* for signaling help; *First Aid Kit* to include bandages, tape, gauze, antiseptic spray, etc. if an injury should occur; *Money*.

5. Communication device - it may be necessary to make an urgent phone call.

6. Map/GPS

Warnings



WARNING

POTENTIAL HAZARD

Failure to follow the age recommendations for this ATV.

WHAT CAN HAPPEN

If children use ATVs that are not recommended for their age, severe injury or death can result.

Even though a child may be within the age group for which an ATV is recommended, he or she may not have the skills, abilities, or judgment needed to operate the ATV safely and may be involved in a serious accident.

HOW TO AVOID THE HAZARD

Never allow anyone under 16 years of age to operate this ATV.

Never allow continued use of the ATV if he or she does not have the abilities to operate it safely.



POTENTIAL HAZARD

Operating this vehicle without proper instruction.

WHAT CAN HAPPEN

The risk of an accident is greatly increased if the operator does not know how to operate this vehicle properly in different situations and on different types of terrain.

HOW TO AVOID THE HAZARD

All operators of this vehicle must read and understand this Operator's Manual and all warning and instruction labels prior to operating this vehicle.

POTENTIAL HAZARD

Operating this ATV on paved surfaces.

WHAT CAN HAPPEN

The ATV tires are designed for off-road use only and are not for use on pavement.

Paved surfaces may seriously affect the handling and control of the ATV and may cause the ATV to go out of control.

HOW TO AVOID THE HAZARD

Whenever possible, avoid operating the ATV on any paved surfaces including streets, parking lots, sidewalks, and driveways. If operating on paved surfaces is unavoidable, travel slowly (less than 10 mph) and avoid sudden turns and stops.



WARNING

Indicates a potential hazard that could result in a serious injury or death.

Warnings

POTENTIAL HAZARD

Carrying a passenger on this ATV.

WHAT CAN HAPPEN

Greatly reduces your ability to balance and control this ATV. Could cause an accident, resulting in personal injury or death to you and/or your passenger.

HOW TO AVOID THE HAZARD

Never carry a passenger. The longer seat is to allow the operator to shift positions as needed during operation.



POTENTIAL HAZARD

Operating this ATV on public streets, roads, or highways.

WHAT CAN HAPPEN

You can collide with another vehicle.

HOW TO AVOID THE HAZARD

Never operate this ATV on any public street, road, or highway, even a dirt or gravel one. In many states it is illegal to operate an ATV on public streets, roads, or highways.

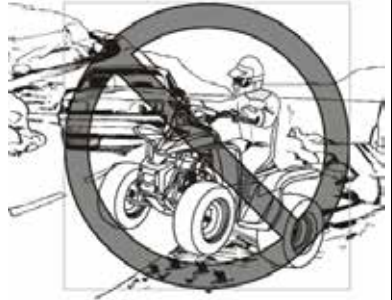

POTENTIAL HAZARD

Operating this ATV after or while consuming alcohol or drugs.

WHAT CAN HAPPEN

Can seriously affect your judgment.
Can cause you to be slow to react.
Can affect your balance and perception.
Can result in an accident.

HOW TO AVOID THE HAZARD

Never consume alcohol or drugs before or while operating this ATV.



POTENTIAL HAZARD

Failure to inspect the ATV before operation.
Failure to properly maintain the ATV.

WHAT CAN HAPPEN

Increases the possibility of an accident or equipment damage.

HOW TO AVOID THE HAZARD

Always inspect the ATV every time you use it. Ensure it is safe operating condition.
Always follow the inspection and maintenance procedures and schedules described in this Operator's Manual.



WARNING

Indicates a potential hazard that could result in a serious injury or death.

Warnings

POTENTIAL HAZARD

Operating this ATV without wearing an approved motorcycle helmet, eye protection, and protective clothing.

WHAT CAN HAPPEN

Operating without an approved helmet increases your chances of a severe head injury or death in the event of an accident.

Operating without eye protection can result in an accident and increases your chances of a severe injury in the event of an accident.

Operating without protective clothing increases your chances of severe injury in the event of an accident.

HOW TO AVOID THE HAZARD

Always wear an approved helmet that fits properly.

You should also wear:

Eye protection (goggles or face shield)

Gloves

Boots

Long sleeved shirt or jacket

Long pants

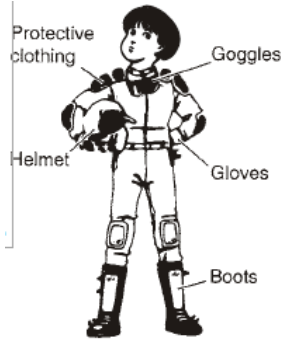

POTENTIAL HAZARD

Operating this ATV at excessive speeds.

WHAT CAN HAPPEN

Increases the chance of losing control of the ATV, which can result in an accident.

HOW TO AVOID THE HAZARD

Always operate at a speed that is proper for the terrain, visibility, operating conditions, and your age and experience.

POTENTIAL HAZARD

Failure to use caution when operating this ATV on unfamiliar terrain.

WHAT CAN HAPPEN

You may encounter hidden rocks, bumps, or holes without enough time to react.

Could result in the ATV going out of control.

HOW TO AVOID THE HAZARD

Use caution when operating on unfamiliar terrain. Always be alert to changing terrain conditions.



WARNING

Indicates a potential hazard that could result in a serious injury or death.

Warnings

POTENTIAL HAZARD

Attempting wheelies, jumps and other stunts.

WHAT CAN HAPPEN

Increases the chance of losing control of the ATV, which can result in an accident.

HOW TO AVOID THE HAZARD

Never attempt stunts, such as wheelies or jumps. Don't try to show off.

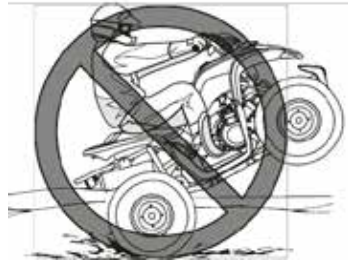

POTENTIAL HAZARD

Failing to keep hands on handlebars or feet on footrests during operation.

WHAT CAN HAPPEN

Removing even one hand or foot can reduce your ability to control the ATV or could cause you to lose your balance and fall off the ATV. If you remove a foot from the footrest, your foot or leg may come into contact with the wheels, which could cause personal injury or cause an accident.

HOW TO AVOID THE HAZARD

Always keep both hands on the handlebars and both feet on the footrests during operation.



POTENTIAL HAZARD

Improper handling of gasoline.

WHAT CAN HAPPEN

Gasoline can ignite and you could be burned. Gasoline is poisonous and can cause injury.

HOW TO AVOID THE HAZARD

Always turn off the engine when refueling.
Do not refuel right after the engine has been running and is still very hot.
Do not spill gasoline on the engine or exhaust pipe/muffler when refueling.
Never refuel while smoking, or while in the vicinity of sparks, open flames, or other sources of ignition such as the pilot lights of water heaters and clothes dryers.

**Never Operate Up or Down Hills
Steeper than 25°**

25° MAX



WARNING

Indicates a potential hazard that could result in a serious injury or death.

Warnings

POTENTIAL HAZARD

Operating on steep hills.

WHAT CAN HAPPEN

This ATV can overturn more easily on steep hills than on level surfaces.

HOW TO AVOID THE HAZARD

Never operate this ATV on hills too steep for the ATV or for your abilities. Practice on smaller hills before attempting larger hills.

POTENTIAL HAZARD

Failure to use caution when operating this ATV on rough, slippery, or loose terrain.

WHAT CAN HAPPEN

You may lose traction or control, which could result in an accident.

HOW TO AVOID THE HAZARD

Do not operate this ATV on rough, slippery, or loose terrain until you have learned and practiced the skills necessary to control this ATV on such terrain.

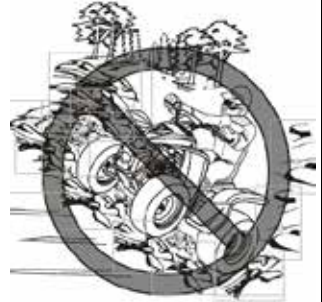

POTENTIAL HAZARD

Climbing hills improperly.

WHAT CAN HAPPEN

You may lose control, which could result in an accident.

HOW TO AVOID THE HAZARD

Always follow proper procedures for climbing hills.

Always check the terrain carefully before you start up any hill.

Never climb hills with slippery or loose surfaces.

Shift your weight forward.

Never open the throttle suddenly. The ATV may flip over backwards.

Never go over the top of any hill at high speeds. An obstacle, sharp drop, or another vehicle or person may be on the other side.



POTENTIAL HAZARD

Failure to use caution in turns; turning too sharp or aggressive.

WHAT CAN HAPPEN

You may lose control, which could result in an accident.

HOW TO AVOID THE HAZARD

Always follow proper procedure for turning. Practice turning at slower speeds before attempting to turn at faster speeds. Do not attempt to turn at excessive speeds or too sharp for the conditions and for your experience level.



WARNING

Indicates a potential hazard that could result in a serious injury or death.

Warnings

POTENTIAL HAZARD

Going down a hill improperly.

WHAT CAN HAPPEN

You may lose control, which could result in an accident.

HOW TO AVOID THE HAZARD

Always follow proper procedures for going down hills.

Always check the terrain carefully before you start down any hill.

Shift your weight backward.

Never go down a hill at high speeds.

Avoid going down a hill at an angle that would cause the ATV to lean sharply to one side. Go straight down the hill where possible.

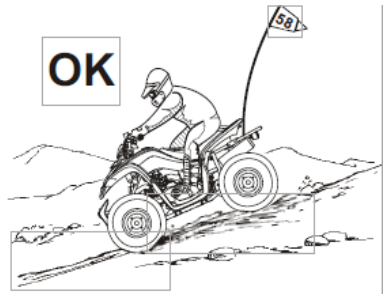

POTENTIAL HAZARD

Stalling, rolling backwards, or improperly dismounting while climbing a hill.

WHAT CAN HAPPEN

You may lose control, which could result in an accident.

HOW TO AVOID THE HAZARD

Use proper gear and maintain steady speed when climbing a hill.

If you lose all forward momentum:

Keep weight uphill.

Apply the brakes.

Engage the parking brake after you are stopped.

If you begin rolling backwards:

Keep weight uphill.

Gradually apply the brakes while rolling backwards.

When fully stopped, engage the parking brake.

Dismount on the uphill side or to a side if pointed straight uphill.

Turn the ATV around and mount following the procedure described in this Operator's Manual.



POTENTIAL HAZARD

Operating the ATV with improper tires or improper or uneven tire pressure.

WHAT CAN HAPPEN

You may lose control, which could result in an accident.

HOW TO AVOID THE HAZARD

Always use the size and type of tires specified in this Operator's Manual.

Always maintain proper tire pressure.



WARNING

Indicates a potential hazard that could result in a serious injury or death.

Warnings

POTENTIAL HAZARD

Operating the ATV in deep or fast flowing water.

WHAT CAN HAPPEN

Tires may float, causing loss of traction and loss of control, which could result in an accident.

HOW TO AVOID THE HAZARD

Never operate the ATV in fast flowing water or in water deeper than the footrests.

Remember that wet brakes may have reduced stopping capability.

Test the brakes after exiting the water. If necessary, apply the brakes several times to dry out the brake pads.



POTENTIAL HAZARD

Skidding or sliding.

WHAT CAN HAPPEN

You may lose control, which could result in an accident.

HOW TO AVOID THE HAZARD

Learn to safely control skidding or sliding by practicing at slow speeds on level, smooth terrain.

On extremely slippery surfaces, such as ice or snow, go slow and use caution in order to reduce the chance of skidding or sliding out of control..

POTENTIAL HAZARD

Operating this ATV with improper modifications.

WHAT CAN HAPPEN

Improper installation and improper use of accessories or modification of the ATV may cause changes in operation or handling which, in some situations, may lead to an accident.

HOW TO AVOID THE HAZARD

Never modify this ATV through improper installation or improper use of accessories.

All parts and accessories added to this ATV should be components designed for use on this ATV and should be installed and used according to instructions.

Never install a twist grip throttle. If you have questions, please contact an authorized dealer.

POTENTIAL HAZARD

Improperly operating over obstacles.

WHAT CAN HAPPEN

You may lose control, which could result in an accident.

HOW TO AVOID THE HAZARD

Before operating on unfamiliar terrain, check for obstacles.

Never attempt to operate over large obstacles, such as large rocks or fallen trees.

When going over obstacles, always follow proper procedures.



WARNING

Indicates a potential hazard that could result in a serious injury or death.

Warnings

POTENTIAL HAZARD

Failure to release the parking brake before operating the ATV.

WHAT CAN HAPPEN

Operating the ATV with the parking brake engaged could cause a change in handling or loss of brakes and cause an accident.

HOW TO AVOID THE HAZARD

Always release the parking brake before operating the ATV.

POTENTIAL HAZARD

Improperly crossing hills or turning on hills.

WHAT CAN HAPPEN

You may lose control, which could result in an accident.

HOW TO AVOID THE HAZARD

Avoid crossing the side of hill or turning on a hill whenever possible. Never attempt to turn the ATV around on any hill until you have mastered the turning technique as described in this Operator's Manual. Practice first on level ground.

If you must cross the side of a hill or turn on a hill: Always follow proper procedures described in this Operator's Manual.

Avoid hills with slippery or loose surfaces.

Shift your weight to the uphill side of the ATV.



POTENTIAL HAZARD

Starting or running engine in a closed area.

WHAT CAN HAPPEN

Exhaust fumes are poisonous and may cause loss of consciousness and death within a short period of time.

HOW TO AVOID THE HAZARD

Always operate your ATV outdoors or in an area with adequate ventilation.

POTENTIAL HAZARD

Hot exhaust system.

WHAT CAN HAPPEN

Someone coming in contact with the exhaust system during or after operation could be burned.

HOW TO AVOID THE HAZARD

Do not touch the hot exhaust system.

Do not park the ATV in a place where others might be likely to come in contact with the exhaust system.

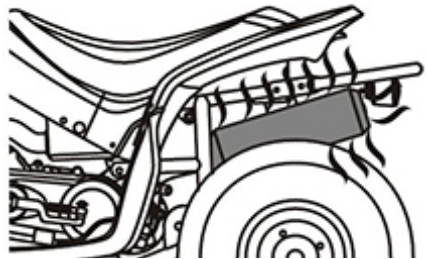

WARNING

Indicates a potential hazard that could result in a serious injury or death.

Warnings

POTENTIAL HAZARD

Operating in areas where you might not be seen by other off-road ATV's.

WHAT CAN HAPPEN

You may be in a collision which may result in personal injury.

HOW TO AVOID THE HAZARD

Always mount a caution flag on the ATV to make you more visible.

Watch carefully for other ATV riders and other vehicles.



POTENTIAL HAZARD

Turning improperly.

WHAT CAN HAPPEN

ATV could go out of control, causing a collision or overturn.

HOW TO AVOID THE HAZARD

Always follow proper procedures for turning as described in this Owner's Manual.

Practice turning at low speeds before attempting to turn at faster speeds. Do not turn at speeds too fast for your skills or the conditions.

Do not turn at excessive speeds.

POTENTIAL HAZARD

Overloading this ATV.

WHAT CAN HAPPEN

Could cause changes in ATV handling, stability and braking which could lead to an accident or injury.

HOW TO AVOID THE HAZARD

Never exceed the stated maximum weight capacity for this ATV.



WARNING

Indicates a potential hazard that could result in a serious injury or death.

Hangtags and Warning Labels

Your ARGO ATV comes with various hangtags and several labels containing important safety information related to the vehicle. Anyone who operates the ATV should read and understand the important safety information before operating.

The hangtags and labels are considered to be a permanent part of the ATV. If a label becomes hard to read or comes off the vehicle, contact your ARGO ATV dealer for a replacement.

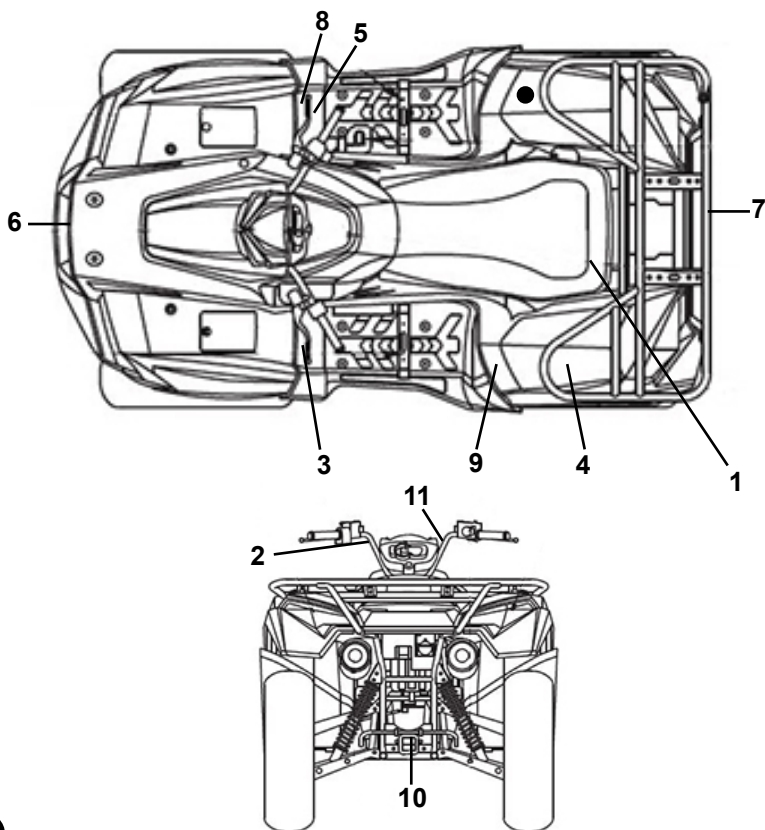

①

VEHICLE EMISSION CONTROL INFORMATION / VEHICLE EVAPORATIVE EMISSION CONTROL INFORMATION	
MODEL NAME: _____	THIS VEHICLE IS CERTIFIED TO OPERATE ON UNLEADED GASOLINE.
ENGINE DISPLACEMENT: _____	
ENGINE FAMILY: _____	ENGINE TUNEUP SPECIFICATIONS:
FERRIATION FAMILY: _____	IGNITION TIMING: _____
EVAPORATIVE FAMILY: _____	IDLE SPEED: _____
ENGINE EXHAUST CONTROL SYSTEM: _____	IDLE MIXTURE: NOT ADJUSTABLE
THIS VEHICLE MEETS U.S. EPA AND CALIFORNIA EXHAUST REGULATIONS FOR _____ MODEL YEAR NEW ATVS AND IS CERTIFIED TO _____ EXHAUST:	VALVE CLEARANCE: INTAKE: _____
EXHAUST EMISSION STANDARDS IN CALIFORNIA.	SPARK PLUG: NGK CR7E
THIS VEHICLE CONFORMS TO CALIFORNIA EVAPORATIVE EMISSIONS REGULATIONS APPLICABLE TO _____ MODEL YEAR NEW ATVS AND IS CERTIFIED TO _____ EVAPORATIVE EMISSION STANDARD IN CALIFORNIA.	FUEL: UNLEADED GASOLINE ONLY - 87(R+N)/2 OCTANE
	OIL: 5W-30 (SEE OWNER'S MANUAL)
	NO OTHER ADJUSTMENT NEEDED.
	MANUFACTURED: _____ / _____ (MONTH/YEAR)

Argo

Hangtags and Warning Labels

General Use Hangtag

②

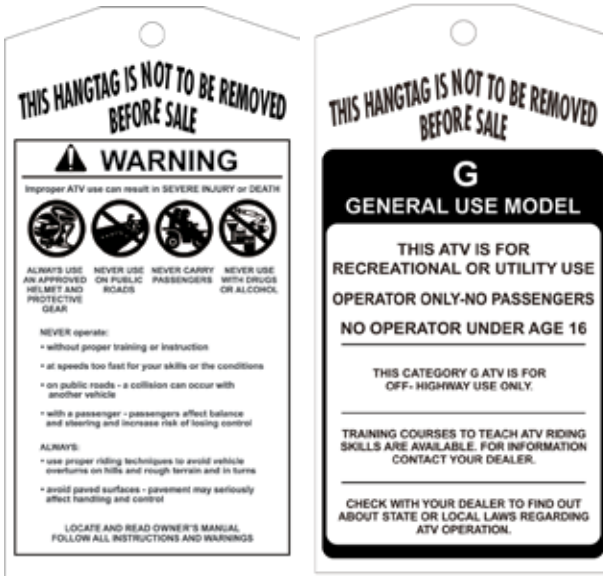

③



Hangtags and Warning Labels

④



⑤



⑥



⑦



⑧



⑨

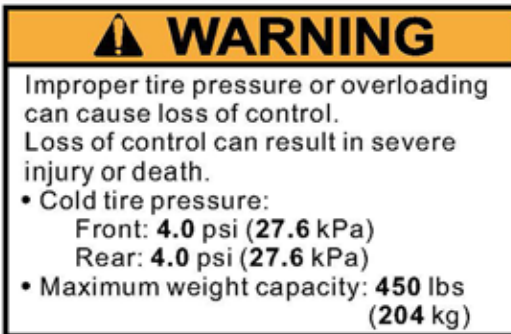

Hangtags and Warning Labels

10

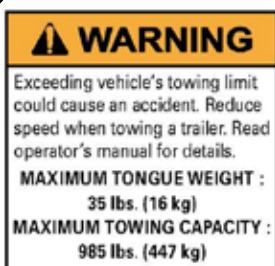

11

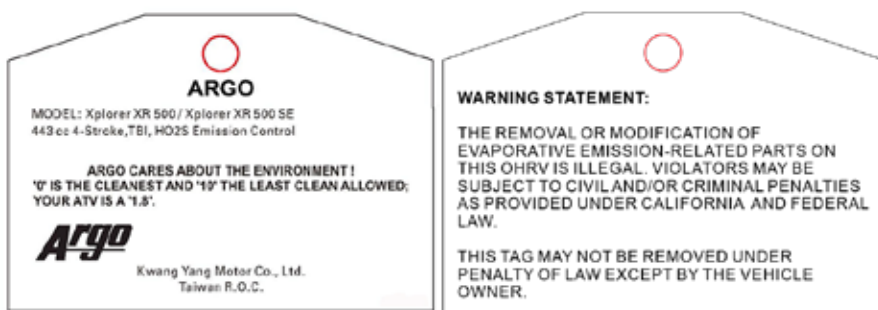

SECTION 3

Specifications

Specifications

ENGINE AND DRIVE	
Type	Four-Cycle/Liquid Cooled
Bore x Stroke	89 x 71.2 mm (3.56 x 2.80 in.)
Displacement	443 cc (27.03 cu in.)
Cylinder Arrangement	Single
Compression Ratio	9.0:1
Starting System	Electric
Lubrication System	Wet sump
Ignition System	ID (Inductive Discharge Ignition)
Generator System	A.C. magneto
Battery Type	12V, 18AH MF
Spark Plug Type	NGK CR7E
Spark Plug Gap	0.028 - 0.032 in (0.7 - 0.8 mm)
Brake Type	Front: Dual disk brake Rear: Single disk brake
Air Filter	Foam (oiled)
Clutch Type	Wet, centrifugal automatic
Fuel Delivery	Electronic Fuel Injection (EFI)
CHASSIS	
Length (Overall)	75 in (190.5 cm)
Width (Overall)	47.6 in (121 cm)
Height (Overall)	47.6 in (121 cm)
Basic Weight (Approx. w/ fuel and oil)	608 lb (275.8 kg)
Seat Height	31.8 in (80.8 cm)
Wheel base	48.2 in (122.5 cm)
Minimum Ground Clearance	10.5 in (26.7 cm)
Suspension	Front: 7.0 in (17.6 cm) Rear: 7.4 in (18.8 cm) Front / Rear: Dual A-arm
Tires	Type: Tubeless XR 500 Front: 24x8-12 Rear: 24x10-12 XR 500 SE Front: 24x8-12 Rear: 24x10-12
Tire Pressure:	Front: 4.0 psi (27.6 kPa) Rear: 4.0 psi (27.6 kPa)

Specifications

MISCELLANEOUS	
Rims	XR 500: Steel XR 500 SE: Aluminum
Fuel (Recommended)	87 Octane Regular Unleaded
Gas Tank Capacity (Rated)	4.0 U.S. Gal. (15 L)
Engine Oil (Recommended)	5W-30
Engine Oil Capacity	Rebuild: 3.02 qt (2.85 L) Change: 2.33 qt (2.20 L) Change w/filter: 2.54 qt (2.40 L)
Front / Rear Gear Case Oil (Recommended)	80W-90 Hypoid
Front Gear Case Capacity	Rebuild: 9.1 fl oz (270 ml) Change: 8.5 fl oz (250 ml)
Rear Gear Case Capacity	Rebuild: 8.5 fl oz (250 ml) Change: 7.78 fl oz (230 ml)
Headlight	12V / 35W / 35W x 2
Tail Light / Brake Light	12V / 5W / 21W
Maximum load capacity: (Including weight of operator, cargo and accessories).	450 lb (204 kg)
Front Rack - Maximum	75 lb (34 kg)
Rear Rack - Maximum	150 lb (68 kg)
Tongue Weight	35 lb (16 kg)
Tongue and Rear Cargo Weight - Maximum	185 lb (84 kg)
Towing Capacity	985 lb (447 kg)
Specifications subject to change without notice.	

SECTION 4

Description and Identification

Identification number records

Record the key identification number, frame serial number, engine serial number and model code information for assistance when order replacement parts.

KEY NO. _____

FRAME NO. _____

ENGINE NO. _____

MODEL CODE _____



Key identification number

The key identification number is stamped on each key. Use this number when ordering a replacement key.

Frame and Engine Serial Number

The frame serial number is stamped on the front of the frame.

The engine serial number is stamped on the left crankcase.

These numbers are required by the dealer to complete any Warranty process. No warranty will be allowed by ARGO if the VIN or ESN has been tampered with in any way.

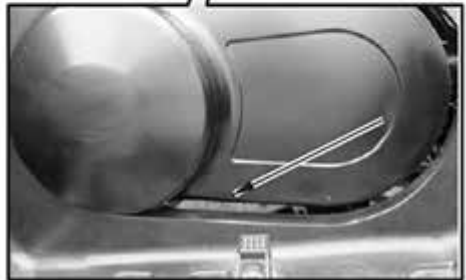

Location of Parts and Controls

Front View

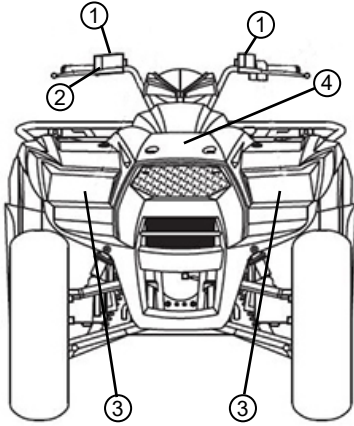

1. Brake Reservoir
2. Throttle Limiter
3. Headlights
4. Electrical Access Panel

NOTE: The machine you have purchased may differ slightly from those shown in the illustrations of this manual.

Rear View

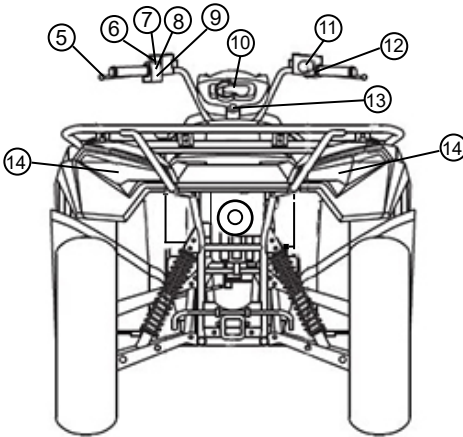

5. Hand Brake Lever (Front/Rear)
6. Headlight Hi/Lo Switch
7. Starter Switch
8. Engine Stop Switch
9. Reverse Override Switch
10. Instrument and Indicators
11. 2WD/4WD/LOCK Selector Switch
12. Throttle Lever
13. Ignition Switch
14. Taillight / Brakelight

Right Side View

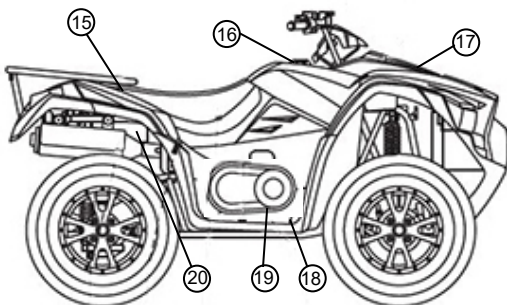

15. Seat Latch
16. Fuel Fill Cap
17. Coolant Reservoir
18. Foot Brake Pedal (Front/Rear)
19. V-Belt Cover Drain
20. Battery

Location of Parts and Controls

Left Side View

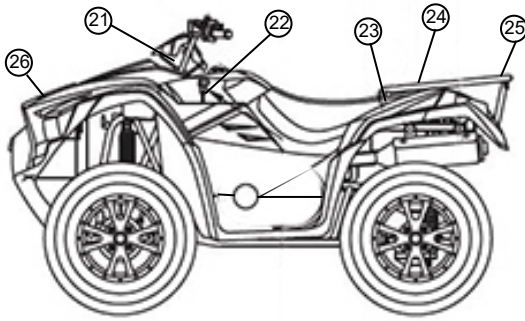

- 21. Accessory Socket
- 22. Drive Select Lever
- 23. Storage Compartment
- 24. Rear Cargo Rack
- 25. Flag Pole Bracket
- 26. Front Cargo Rack

Control Functions

Ignition Switch

Functions of the respective switch positions are as follows:

“OFF” position:

All electrical circuits (except the accessory plug) are switched off. The engine will not start or run. The key can be removed in this position.

“ON” position:

The ignition circuit is complete and the engine can start and run. The key cannot be removed in this position.

“LIGHTS” position:

The ignition circuit is complete and the engine can start and run, and the headlights and taillights are on. The key cannot be removed in this position.



NOTE: The accessory plug is powered by the battery at all times.



CAUTION

Always leave the ignition switch in the “OFF” position when the engine is not running. Leaving the ignition switch in the “ON” position when the engine is not running may cause the battery to discharge.

Handlebar Switches

- (1) Engine start switch
- (2) Headlight switch
- (3) Emergency stop switch
- (4) Reverse override switch

Emergency Stop Switch

When the switch is at the “RUN” position, the engine will operate. When the switch is at the “OFF” position, the engine will not operate.

This switch is intended primarily as a safety or emergency control, and it should normally remain at the “RUN” position.

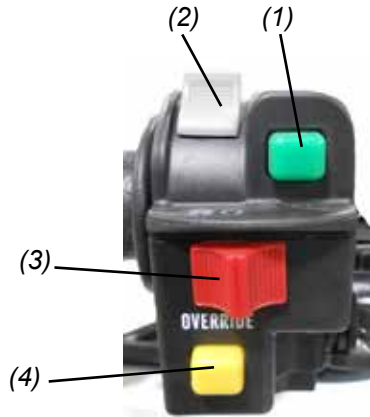

NOTE: If you stop your ATV by turning the emergency stop switch to the “OFF” position, be sure to turn the ignition switch to the “OFF” position to prevent battery discharge.

Control Functions

Headlight Switch

The headlight switch has three position locations - running lights, low beam and high beam. The lights will illuminate when turning the ignition key to the "Lights" position..

High beam headlight

Low beam headlight

Headlight "OFF"



Engine Starter Button

With the transmission in "N" (neutral), the key switch in the "ON" position and the emergency stop switch to the "RUN" position, depress the starter button to start the engine.

NOTE: The engine can be started in any gear if the brake lever is applied. However, it is recommended to shift into "N" (Neutral) or "P" (Park) before starting the engine. If either indicator light fails to illuminate when the gear select lever is in the neutral or park position, have an ARGO dealer inspect the electrical circuit.



CAUTION

If the starter button is pushed with the ignition switch in the "ON" position and the emergency stop switch in the "OFF" position, the starter motor will be activated but the engine will not start. Premature starter failure may occur. Ensure the emergency stop switch is in the "RUN" position.

Reverse Override Button

By pressing the reverse override button when the ATV is in REVERSE will bypass a feature of your ATV ignition that reduces engine RPM in reverse.



CAUTION

Be alert when using the reverse override button as the ATV's engine performance and speed will be increased. Always look for obstacles before operating your ATV in reverse.

Control Functions

2WD / 4WD Selector Switch

The 2WD/4WD selector switch allows you to operate your ATV in either two-wheel drive (rear wheels powered) or four-wheel drive (open front differential).

The 2WD/4WD/LOCK select switch is located above the throttle lever. To select the LOCK mode, rotate the switch to the LOCK position. Present drive mode is displayed on the multi-functional gauge. To disengage power to the front wheels, depress the 2WD/4WD switch.



CAUTION

Never operate the 2WD/4WD selector switch while your ATV is in motion as you may damage the differential.

Transmission Ranges

This ATV is equipped with an automatic, dual-range transmission with reverse capability. To shift your ATV into the different drive modes, follow the below steps.

To properly change transmission range:

1. Apply brake.
2. Move shift lever to the desired range.
3. Release brake.

NOTE: The HIGH range is for normal riding conditions with light loads. The LOW range is for carrying heavy loads, slow speeds or trailer towing. LOW range position provides slower speed and greater torque to the wheels.



Low Range High Range Neutral Reverse



CAUTION

Always shift the transmission into LOW range when operating on wet or uneven terrain, when towing or pushing heavy loads, or when using a plow. Failure to follow this caution may result in premature V-belt failure or other damage to the drive system.

3. To shift into REVERSE gear from Neutral, move the shift lever outward and back to the "R" position.



CAUTION

Never shift the transmission while your ATV is in motion. Should your ATV be on a surface that is not level, engage the parking brake (brake lever lock) before shifting into another gear or into reverse.

Control Functions

Brakes

Your ATV is equipped with front and rear hydraulic brakes that can be activated with hand and foot controls.

LEFT HAND BRAKE LEVER - Activates front and rear brakes

FOOT BRAKE PEDAL - Activates rear brakes

Left Hand Brake Lever and Parking Brake Lock (Front and Rear Wheels)

The left hand brake mounted on the left handlebar activates the front and rear brakes on your ATV. To apply the front and rear brakes, squeeze the lever towards the handlebar grip.

To engage or release the parking brake, use the following procedure.

1. Squeeze the hand brake lever two or three times to achieve maximum brake pressure; then release.
2. Depress and hold the brake lever.
3. While holding in the hand brake lever, engage the parking brake lock.



Parking brake lock

Brake lever

NOTE: The parking brake lock will click as it engages and the brake lever will not return to its released position.

4. Release the parking brake lock by squeezing the brake lever. Once the locks are disengaged, the lever will return to its released position.

Use the following procedure to verify that the parking brake lock locks the front and rear wheels when engaged:

1. Squeeze the hand brake lever two or three times.
2. Engage the parking brake lock.
3. Attempt to push the ATV.

NOTE: The parking brake lock must lock the ATV's front and rear wheels. If it does not, take your ATV to an authorized ARGO dealer for service.



WARNING

Ensure the parking brake lock has been disengaged before operating your ATV. An accident can result if the parking brake lock is left engaged while the ATV is being operated. Never rely on the parking brake as the sole means of securing the ATV when parking on a hill. Always block the downhill side of the ATV's wheels or park the ATV perpendicular to the hillside.

Control Functions

Rear Brake Pedal

Depressing the foot brake pedal with your right foot will apply the rear brakes.



WARNING

- Before operating, check whether there is appropriate resistance on the brake at the brake lever. Also check there is sufficient quantity of brake fluid in the reservoir.
- Before operating, check the brake system. The gap of the brake lever end should be 12 mm approximately. Inform your local dealer of possible deviations.
- Irregularities of brakes such as leaks and poor performance should be inspected by an authorized ARGO dealer.



WARNING

Prolonged and repetitive use of the ATVs hydraulic brake for high speed stops will cause overheating of the brake fluid and premature brake pad wear which can cause unexpected loss of braking ability. Note the position of your right foot so it is not resting or applying pressure to the rear foot brake. Premature brake failure may occur.

Throttle Lever

The position of the throttle lever controls engine RPM. Pushing it forward increases engine RPM, allowing the lever to return to its original position decreases engine RPM.



WARNING

POTENTIAL HAZARD

Throttle malfunction.

WHAT CAN HAPPEN

The throttle could be hard to operate, making it difficult to speed up or slow down when you need to. This could cause an accident.

HOW TO AVOID THE HAZARD

Check the operation before you start the engine. If it does not work smoothly, check for the cause.

Correct the problem before riding the ATV.

Consult an authorized ARGO dealer if you can not locate or solve the issue yourself.

Control Functions

Speed Limiter

The speed limiter keeps the throttle from fully opening, even when the throttle lever is pushed to the maximum. Turning IN the adjuster limits the top speed of the ATV. Turning OUT increases the top speed of the ATV.

1. Adjuster
2. Locknut
- A. 0.52 in (13 mm maximum)

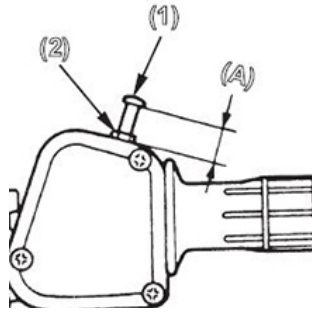

NOTE: Your ATV is equipped with an ignition limiter that retards timing when approaching maximum engine RPM. When this RPM limiter is activated, it can be misinterpreted as a high-speed ignition misfire.



WARNING

POTENTIAL HAZARD

Improper adjustment of the speed limiter and throttle.

WHAT CAN HAPPEN

The throttle cable could be damaged. Improper throttle operation could result causing you to lose control of the ATV and be injured or cause an accident.

HOW TO AVOID THE HAZARD

Do not turn the speed adjuster out more than 0.52 in (13 mm). Always make sure the throttle lever free play is adjusted to 0.12 - 0.2 in (3 - 5 mm).

Control Functions

Multifunction Meter



Adjust / Set Button (1) - Use in conjunction with the **Mode Button (2)** to set the clock and reset the trip meter to zero. This button is also used to toggle between MPH and km/h.

NOTE: Depress and hold the **Adjust / Set Button (1)** and the **Mode Button (2)** simultaneously for three seconds to activate the gauge setting functions. Approximately ten seconds after releasing these buttons, the display will return to normal operating mode.

Mode Button (2) - Use this button to toggle between the Clock, Hour Meter, Odometer and Trip Meter display (5) on the LCD. Use in conjunction with the Adjust / Set Button (1) to set the clock or reset the trip meter to zero.

Gear Position Indicator (3) - Indicates which transmission mode is selected: **R** = Reverse, **N** = Neutral, **L** = Low Range, **H** = High Range. An "E" will be displayed if the transmission is not engaged in a selected gear.

Speedometer (4) - Indicates the approximate ATV speed in miles per hour (MPH) or kilometers per hour (km/h).

Clock / Hour Meter / Odometer / Trip Meter (5) - Displays time, total engine hours, total miles / kilometers traveled, or trip miles / kilometers traveled. To set the clock, the steps A through C below. To reset the trip meter, proceed to step D.

- A. To set the clock, press and hold the Mode Button (2) until CLOCK is displayed.
- B. Press and hold the Adjust / Set Button (1) and Mode Button (2) approximately three seconds until the hour display starts to flash, then release the buttons and press the Mode Button (2) to set the hour.

NOTE: The hour display will read from 1 to 24 and may be cycled rapidly by holding the Mode Button (2) down for three seconds.

- C. After you have selected the desired hour, press and release the Adjust / Set Button (1) to toggle the clock to the minute display (the minute digits will flash, then press the Mode Button (2) to set the minutes. After approximately ten seconds, the minute display will stop flashing and the gauge will return to normal operation.

Control Functions

NOTE: Power for the clock memory is supplied through the 15 amp accessory fuse; the gauge verifies when the ATVs ignition is turned to the “ON” position. If the clock loses its memory power supply (failed fuse, etc.), the gauge will “power up”, reset, and shut down repeatedly until clock memory power supply is restored. Always check the 15 amp accessory fuse first if this gauge begins to cycle through this “power up” sequence.

- D. To reset the tip meter, press and hold the Mode Button (2) until TRIP is displayed in the display; then press and hold the Adjust / Set Button (1) and Mode Button (2) until the trip meter reads zero (0).

Fuel Gauge (6) - The fuel gauge shows the approximate fuel supply available in a graduated display. The normal operating fuel range is with the section between the segment “F” and segment “E”. When the segment “E” or the fuel indicator flashes, fuel will be low and you should refill the tank as soon as possible.

CELP Indicator (7) - If flashing, it indicates that a fault has been detected in the EFI or electrical system. Requires immediate inspection by an authorized ARGO dealer.

NOTE: The CELP indicator illuminates momentarily when the ATV is turned “ON” before the engine is running.

Coolant Temperature Warning Symbol (8) - When the coolant is over the specified temperature, the coolant temperature warning symbol will flash. If this occurs, stop the engine and check the reserve tank coolant level.

High Beam Indicator Light - This light is illuminated when the headlight “high beam” is on.

Tachometer - Indicates the engine speed in the revolutions per minute (RPM).

Fuel Tank Cap

After refueling, be sure to tighten the fuel tank cap.



Seat Removal

To remove the seat, lift upward on the seat lock lever and pull up the seat at the rear of the ATV.



Control Functions

Seat Installation

To install the seat, slide the front of the seat into the seat retainers and press the rear of the seat down firmly until it locks into place.

NOTE: Ensure the seat is properly fitted into position and locked before operation.

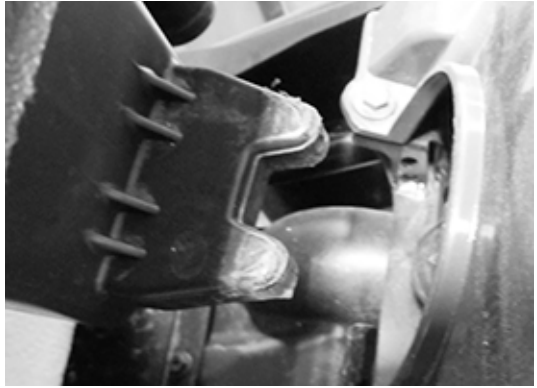

Safety Flag Bracket

To mount a safety flag into the bracket.

NOTE: Safety flags are required in some riding areas. Check local regulations before riding.



Fuses

The ATV fuses are located in a power distribution module in front of the steering post under the electrical access panel. If there is any type of electrical system failure, always check the fuses first.

NOTE: To remove a fuse, compress the locking tabs on either side of the fuse cover and lift it out.



CAUTION

Always replace a failed fuse with a fuse of the same type and rating. If the new fuse fails after a short period of use, consult an authorized ARGO dealer immediately.

Electrical Output Terminals

The accessory plug is located on the front body panel.



CAUTION

Always use electrical accessories on your ATV that draw less than 180 W.

Control Functions

To use the accessory socket:

1. Turn the ignition switch to the "ON" position, then start the engine.
2. Turn the headlights "OFF".
3. Open the accessory socket cap and then insert the accessory plug into the socket.

Be sure the engine is running and the headlights are turned off before using the accessory socket, otherwise you may drain the battery.

The accessory socket rated capacity is DC 12V, 120 W (10A) or less. If you exceed this capacity, you may fail a fuse.

Storage Compartment

The storage compartment is located under the seat.

Be careful not to flood this area when washing your ATV or riding through water, and never put any electric conduction material in the storage compartment.



Tool Kit

A tool kit is provided with your ATV. It is recommended to put the tool kit in the vinyl bag and always carry them in the storage compartment under the seat.



1. Rubber band
2. Tool bag
3. Screwdriver handle
4. Standard/Phillips screwdriver
5. Spark plug wrench
6. Spanner wrench
7. 10/12 mm wrench
8. Air pressure gauge



SECTION 5

Getting to Know Your ATV

Getting To Know Your ATV

This ATV is for recreation use. This section, riding your ATV, provides general ATV riding instructions for recreational riding. The skills and techniques described in this section, however, are appropriate for all types of riding. Riding your ATV requires special skills acquired through practice over a period of time. Take the time to learn the basic techniques well before attempting more difficult maneuvers.

Riding your new ATV can be a very enjoyable activity, providing you with hours of pleasure. But it is essential to familiarize yourself with the operation of the ATV to achieve the skill necessary to enjoy riding safely. Before you begin to ride, be sure you have read this Owner's Manual completely and understand the operation of the controls. Pay particular attention to the safety information and special safety messages. Please also read all caution and warning labels on your ATV.

Before Riding

Before operating the ATV, read and understand the "Important Message" section (beginning on page 7) carefully.

You need to prepare before riding. This includes getting proper instruction, making sure your ATV is in good operating condition, and learning some basic safe-riding rules.

Rider Preparation - Age Recommendation

The minimum age for this ATV model is 16. For safety, never let anyone under 16 years old operate this vehicle.

Pre-operation Checks

Always inspect your ATV each time you use it to make sure the ATV is in safe operating condition. Perform the pre-operation checks listed in this manual. Always follow the inspection and maintenance procedures and schedules described in the Owner's Manual.

Safe Riding Rules

Please note that the safe Riding Rules apply to all ATV riders.

Even if you are an experienced rider, or after you become one, continue to follow these guidelines for your own safety and enjoyment.

Protective Apparel

Always wear an approved motorcycle helmet when riding your ATV. You should also always wear goggles or a face shield, gloves, boots, a long-sleeved shirt or jacket, and long pants.

Getting To Know Your ATV

Weight Limits

There are limits to how much weight can be carried on your ATV. See Weight Limits section in the Specifications section. Modifying your ATV, using non-standard equipment or riding on terrain that is not flat and smooth could further reduce these limits.

Never exceed the stated load capacities for this vehicle. Cargo should be properly distributed and securely attached. Reduce speed when carrying cargo or pulling a trailer and allow greater distance for braking.

Accessories

Genuine ARGO accessories have been specifically designed for and tested on this vehicle. Because ARGO cannot test all other accessories, you are personally responsible for properly selecting, installing, and using non- ARGO accessories.

1. Carefully inspect the accessory to make sure it does not block any lights, reduce ground clearance, or limit suspension travel, steering travel, or other controls.
2. Make sure the accessory does not interfere with your ability to shift body position on the seat or operate hand and foot controls.
3. Do not add electrical equipment that will exceed the vehicle's electrical system capacity. A failed fuse could cause a loss of lights or engine power.

No Modifications

Modifying this ATV or removing original equipment may render the vehicle unsafe or illegal. Spark arresters and mufflers are required in most areas. Don't modify your exhaust system or emission control system components. Remember, excessive noise bothers everyone and creates a bad image for off-road vehicles.

For Off-Road Use Only

This ATV is designed and manufactured for off-road use only.

Do not ride in areas posted "no-trespassing". Do not ride on private property without getting permission.

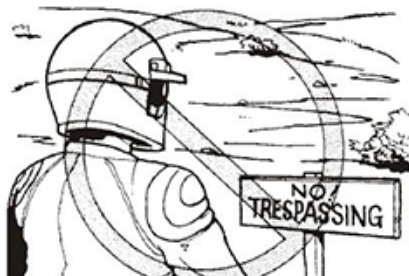

Environment

The environment that you will operate your ATV in is often harsh and sometimes dangerous if you don't take proper precautions.

Weather

You need to consider the weather when you participate in an outdoor activity such as riding an ATV. It is dangerous to ride your ATV when the weather is bad or could potentially become bad. Before starting out on your ATV, check the weather forecast for the location and duration of your ride.

Getting To Know Your ATV

Terrain

Always pay close attention to the terrain you're on, even if it is in an area familiar to you. Do not assume that the landscape you're used to doesn't change. Changes to landscape can happen at any time; fences can be constructed and excavations dug in a short period of time. Weather, climate, and development take their toll as well as erosion and other changes that can affect your ATVs ability to ride smoothly and securely.

Because terrain can constantly change in configuration, you may not know how it has changed until you get there. Whether it's familiar or not, check out your surroundings before and during your ride.

Night Riding

It is best to avoid riding your ATV at night when visibility is limited. With little to no light, it is difficult to see what is around you.

If you must ride at night, proceed slowly and never ride at a speed that would prevent you from reacting to something that could come up in the limited view of your ATVs headlamps.

Paved Surfaces

Avoid riding your ATV on paved surfaces. Your ATV was not designed for use on pavement and its handling will become more difficult and unpredictable that when riding on non-paved surfaces.

Trail Riding

Use sound judgment when trail riding with your ATV. You should only ride on trails that suit your riding ability. If the trail is very rugged, standing up on your footrests will make it easier for you to endure the rough terrain.

Make yourself visible to others by using your ATVs headlights and taillights. If you stop, pull completely off the trail in a way to protect yourself, your ATV, and the environment.

Sloped trails (trails that slant to allow rain to run off) make trail riding more challenging. To ride on sloped trails, keep your weight shifted towards the uphill of the slope. Proceeding slowly with your weight shifted towards the slope will help you from sliding off the trail.

Be aware of the rules and the laws that govern the area in which you will be riding your ATV. Learn which trails you can legally and safely ride on and who else might be on those trails. Be aware of the signs posted in the areas you ride that would designate trail types and restrictions.

Getting To Know Your ATV

Turning Your ATV



WARNING

Always follow proper procedures for turning as described in this Owner's Manual. Practice turning at low speeds before attempting to turn at faster speeds. Do not turn at speeds too fast for your skills or the conditions. ATV could go out of control causing a collision or overturn.

Leaning, Weight Shift, and Balance

When turning your ATV, the goal is to move forward and slide over to the side of the seat that is on the inside of the turn. Support your body weight on the outside footrest and lean your body into the inside of the turn. Pay attention to the ATV's handling. If you feel the tires coming off the ground, reduce speed, shift more of your body weight to the side of the ATV that is lifting, and make the turn wider if possible.



Wide Turns

About 20% of ATV accidents happen during turns. If you don't understand turning techniques, you can lose control of your ATV by losing traction, plowing, or tipping. Use this riding method for wide turns:

1. Ease off the throttle as you approach the turn to slow down.
2. Use the principles of leaning, weight shifting, and balancing: shift your body weight to the inside of the turn.
3. Gradually increase your speed as you come out of the turn.



Getting To Know Your ATV

Sharp Turns

After mastering wide turns, practice the advanced skill of sharp turns. Use this riding method for sharp turns:

1. Ease off the throttle as you approach the turn to slow down.
2. Use the principles of leaning, weight shifting, and balancing: shift your body weight to the inside of the turn.
3. You may have to lean into the turn more than you do in a wide turn.
4. If shifting your weight and balance are not enough to keep the ATV tires on the ground, straighten out the handlebars as much as you can.
5. Gradually increase your speed as you come out of the turn.



Quick Turns

Quick turns are the most difficult turns, and should only be attempted after you have become very familiar with the handling characteristics of your ATV. Use this riding method for quick turns:

1. Ease off the throttle as you approach the turn to slow down.
2. Turn the handlebars, shift your weight, and balance at the same time as you enter the turn (use the principles of leaning, weight shifting, and balancing: shift your body weight to the inside of the turn).
3. Follow your weight shift with slight acceleration.
4. For multiple turns, repeat this movement as needed.
5. To make your turn quicker, try raising yourself off the seat a few inches as you shift your weight to your outside foot.



Getting To Know Your ATV

K-Turns

Use the K-turn maneuver if you accidentally stall your ATV while riding uphill. Use a K-turn will enable you to point the ATV downhill in a controlled manner and prevent the ATV from rolling back. Use this turning method for K-turns:

1. Stop where you are, apply the brakes, and shift the transmission into neutral ("N").
2. Shut off the ATVs engine.
3. Keep your body weight shifted forward.
4. Dismount the ATV on the uphill side.
5. If you are to the left of the ATV, turn the handlebar all the way to the left.
6. Partially release the brake, but lightly hold the brake lever so you can control the ATV rolling.
7. Let the ATV roll slowly to your right side until it faces slightly downhill.
8. Re-apply the brakes firmly.
9. Re-mount the ATV from the uphill side, and keep you weight shifted uphill when you sit down on the seat.
10. Start the engine and follow the method for riding downhill.

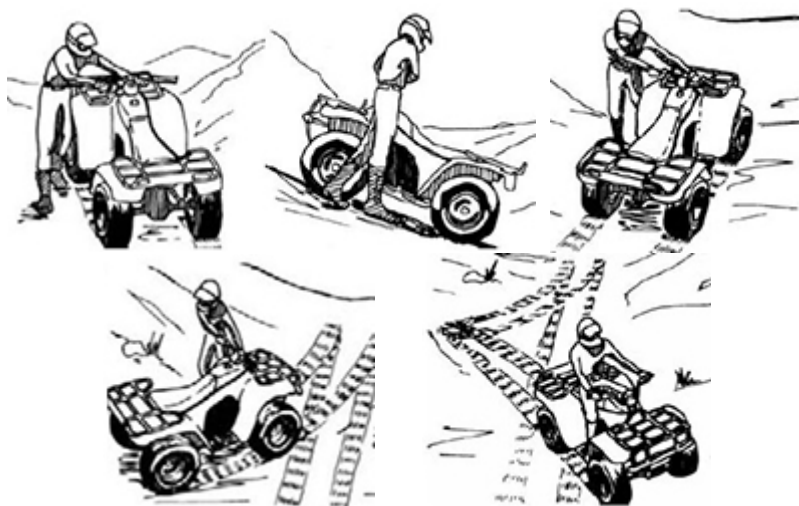

Getting To Know Your ATV

Climbing Uphill



WARNING

Climbing hills improperly can cause overturns or loss of control. Use proper riding techniques described in this Owner's Manual.

Approximately 20% of ATV accidents that happen while riding on hills and as a result of the ATV rolling or flipping over. Use extreme caution when riding your ATV on hills. Use this method for riding uphill:

1. Slightly accelerate before you start to climb a hill and maintain a steady pace.
2. Lean as far forward as possible. For steeper hills, lift slightly off the ATV seat, stand and lean forward.
3. If you lose speed, carefully apply more throttle. Be prepared to release the throttle so your front tires do not lift.
4. If you still have forward momentum and the terrain permits, do a U-turn and go back down the hill.
5. If you have lost all forward motion, use the K-turn maneuver and go safely down the hill.

Never Operate Up or Down Hills Steeper than 25°

25° MAX



WARNING

Stalling, rolling backwards or improperly dismounting while climbing a hill could result in ATV overturning. If you cannot control the ATV, dismount immediately on the uphill side.

Getting To Know Your ATV

Riding Down Hill



WARNING

Going down a hill improperly could cause overturns or loss of control. Always follow proper procedures for going down hills as described in this Owner's Manual.

Success in riding downhill depends on how familiar and skilled you are with using your brakes. Use care and balance braking force and downhill speed so you don't lose control. Use this method for riding downhill:

1. Shift your body weight as far back on the seat as possible.
2. Do not shift the ATV into neutral ("N").
3. Lightly apply the brakes and use very little throttle.



Crossing a Slope



WARNING

Improperly crossing hills or turning on hills could cause loss of control or cause the ATV to overturn.

Side-hilling requires advanced ATV riding skills as the terrain can be difficult and unpredictable. Whether your skills are advanced or not, try to avoid this kind of riding. If you are in a situation where you absolutely have to side-hill on your ATV, use this riding method:

1. Keep the ATV speed low and consistent.
2. Shift all your body weight to the uphill side of the seat; also, support your weight on the uphill footrest.
3. Steer as if you are driving into the hill.
4. If your ATV feels like it may tip over, turn the handlebar downhill. If that is not possible because of the terrain or other conditions, stop and get off the ATV. Dismount your ATV on the uphill side.



Getting To Know Your ATV

Swerving

Swerving is an emergency maneuver required to avoid an obstacle, but is similar to a quick turn. Swerving differs as a quick turn involves slight acceleration during the turn. Do not accelerate if you swerve to maintain better control of your ATV. If you are in a situation where you feel you must swerve, use this riding method:

1. Ease off the throttle as you approach the obstacle.
2. Turn the handlebar, and at the same time, shift your weight and balance as you swerve. Using the principles of leaning, weight shifting, and balancing, shift your body weight to the inside of the turn.
3. Avoid using the brakes until the obstacle avoidance swerve is complete and you have regained full control of your ATV.



Riding Over Rough Terrain



WARNING

Riding improperly over obstacles could cause loss of control or a collision. Before operating in a new area, check for obstacles. Never attempt to ride over large obstacles, such as large rocks or fallen trees. When you go over obstacles, always follow proper procedures as described in the Owner's Manual.

Crossing obstacles is dangerous, and even experienced ATV riders should avoid this practice if possible. Riding over logs, rocks, and ruts means you must combine all the active riding skills into one big motion. Your ATV will respond differently for different obstacles (logs, rocks, etc.), but these are general guidelines for overcoming two-track (both tires contacting the obstacle at the same time) obstacles.

1. Keep the ATVs speed very low - less than 5 MPH.
2. Approach the obstacle head-on.
3. Lift up slightly off the seat.
4. Keep your weight on the footrests.
5. Apply a slight amount of throttle when the front tires make contact with the obstacle.
6. Lean forward and release the throttle when the front tires clear the obstacle.
7. Keep your body loose to absorb any shock from going over the obstacle.
8. If the ATV begins to tip, shift your weight to maintain balance.

Getting To Know Your ATV

To clear a single-track (only one tire contacts the obstacle) hazards, follow the same guidelines, except:

1. Use the ATVs momentum to clear the obstacle.
2. Do not pull up on the handlebar.
3. Do not apply any throttle.



Crossing Through Shallow Water



WARNING

Operating this vehicle through deep or fast flowing water can lead to loss of control or an overturn. To reduce your risk of drowning or other injuries, use care when crossing through water. Never operate this ATV water deeper than the depth specified in your Owner's Manual, as tires may float, increasing the risk of an overturn.

The ATV can be used to cross slow moving, shallow water up to the bottom of the running boards. Before entering the water, choose your path carefully. Enter where there is no sharp drop off, and avoid rocks or other obstacles, which may be slippery or upset the ATV. Drive slowly and carefully.

Test your brakes after leaving the water. If necessary, apply them several times to let the friction dry out the linings. Do not continue to ride your ATV without verifying that you have regained proper braking ability.



WARNING

Wet brakes may have reduced stopping ability, which could cause loss of control.

After riding your ATV in water, be sure to drain the trapped water by removing the check hose at the bottom of the air filter case to drain any water that may have accumulated.



CAUTION

Riding your ATV through water deeper than the footrests may lead to severe engine damage due to water ingestion.

Getting To Know Your ATV

Sliding and Skidding



WARNING

Skidding or sliding improperly may cause you to lose control of this ATV. You may also regain traction unexpectedly, which may cause the ATV to overturn.

Care should be used when riding on loose or slippery surfaces since the ATV may slide. If unexpected and uncorrected, sliding could lead to an accident.

To reduce the tendency for the front wheels to slide in loose or slippery conditions, positioning your weight over the front wheels will sometimes help.

If the rear wheels of your ATV start to slide sideways, control can usually be regained by steering in direction of the slide. Applying the brakes or accelerating is not recommended until you have corrected the slide.

With practice, over a period of time, skill at controlled sliding can be developed. The terrain should be chosen carefully before attempting such maneuvers since both stability and control are reduced.

Bear in mind that sliding maneuvers should always be avoided on extremely slippery surfaces, such as ice, since all control may be lost.

Crossing Roads

Use extreme caution while crossing a road, avoid if at all possible. If you must cross a road:

1. Stop completely before crossing a road.
2. Check both directions for oncoming traffic.
3. NEVER attempt to cross a road or intersection at a blind crossing.
4. Drive straight across to the opposite side.
5. Allow plenty of time to safely cross the road.
6. Know your state and local laws. It is illegal to cross public roads in some places.

Cold Weather Operation

NOTE: Ensure all control levers operate as intended. Make sure the footrests are free and clear of ice and snow.



WARNING

For your personal safety, it is important to wear the proper type and amount of cold-weather clothing according to the coldest anticipated temperatures.

1. With the transmission in neutral ("N") and the brake lever lock released, move the ATV forward and backward to ensure the wheels roll freely. If the ATV does not move, the tires may be frozen to the ground or the brake pads may be frozen to the rotors or drums.
2. If the tires are frozen to the ground, pour warm water around them to melt any ice around the tires.



CAUTION

Before operating, manually move the ATV forward and backward to ensure the wheels roll freely.

Getting To Know Your ATV

3. If the brakes are frozen, move the ATV to a warm location to thaw out the brakes.



WARNING

For your personal safety, do not attempt to free frozen brakes by pouring warm water on the brakes.

NOTE: After the brakes have thawed, dry them by compressing the brake lever several times while riding slowly.

NOTE: After riding through snow, slush, water or mud, it is recommended to dry the brake system before parking the ATV.



WARNING

For your personal safety, go slow and be extra careful while riding on snow or ice-covered terrain. Always be alert to the changing terrain while operating the ATV.

1. Practice driving in an open snow or ice-covered area at slow speeds.
2. Learn how the ATV responds to steering and braking on snow or ice-covered terrain.

Braking

Practice starting and stopping at slow speeds. Gradually work up to faster starts and stops.

1. Steer straight ahead. Close the throttle completely, remove your thumb from the throttle lever.
2. To apply both the front and rear brakes, compress the left hand brake lever located on the handlebars. To apply rear brakes, depress the foot brake pedal.

Gradually increase the lever pressure as you feel the brakes slowing your speed. The pressure used depends on your speed and the condition of the terrain you are riding. Slick, slippery or muddy ground requires gentler braking.

Compressing the brake lever too hard may cause the front and/or rear wheels to skid or slide out of control. If this happens, release all pressure on the lever immediately. Steer straight ahead to regain control. Then gently reapply the brakes.

Independent use of only the front or rear brakes reduces stopping performance. Extreme braking may cause the wheels to lock, reducing control of the ATV.

When possible, reduce speed or brake before entering a turn. Closing the throttle or braking in mid-turn may cause wheel slippage which will reduce control of your ATV.

Never hold the brake and accelerate at the same time. This will cause the brake system to overheat.

Reversing

Remember, it is difficult to see behind you as you back up your ATV.

1. Proceed slowly, using a slight amount of throttle.
2. Keep the handlebar straight.
3. Avoid backing down hills; use a U-turn or a K-turn to turn around.

Getting To Know Your ATV

Parking

Parking requires following the previous rules of braking; then:

1. When the ATV comes to a complete stop, shift ATV into the neutral “N” position.
2. Stop the engine using the engine stop switch located on the handlebar.
3. Turn the ignition switch to the “OFF” position.
4. Engage the parking brake lock.

NOTE: If parking on a hill or slope, shift the ATV into forward or reverse gear.



Parking brake lock

Brake lever

Parking on a Hill or Slope

1. Bring the ATV to a complete stop, shift ATV into a forward or reverse gear position.
2. Stop the engine using the engine stop switch located on the handlebar.
3. Turn the ignition switch to the “OFF” position.
4. With the front and rear brake (left brake lever) applied, apply the parking brake lock.



Parking brake lock

Brake lever



WARNING

POTENTIAL HAZARD

Parking on a hill or other incline.

WHAT CAN HAPPEN

ATV could roll out of control, increasing the risk of an accident or injury.

HOW TO AVOID THE HAZARD

Whenever possible, avoid parking on hills or other inclines. If you must park on an incline, apply the parking brake, and block the front and rear wheels with rocks or other objects. Do not park the ATV at all on hills that are so steep you could not walk up them easily.

Getting To Know Your ATV

Stopping the Engine

To stop the engine, slide the engine stop switch to the “OFF” position or turn the ignition switch key to the “OFF” position.

NOTE: If you stop your ATV by turning the engine stop switch to the “OFF” position, be sure to turn the ignition switch to the “OFF” position to prevent battery discharge.

Trailer and Towing



WARNING

Never use the cargo racks as a towing or trailering point.

Your ARGO ATV is equipped with a frame-mounted receiver for a standard 2 inch (5.1 cm) receiver hitch. A standard receiver hitch must be purchased separately.

When loading a trailer properly, two items are critical. Gross Trailer Weight (the weight of the trailer PLUS the weight of the cargo) and Trailer Tongue Weight. See the Specification section.



WARNING

Ensure the load in the trailer is properly secured and will not shift while moving. Also, do not overload the trailer’s capacity.



WARNING

NEVER EXCEED ANY OF THE ATVs WEIGHT RESTRICTIONS

Trailer Tongue Weight is the downward force exerted on the hitch by the trailer coupler when the trailer is fully loaded and the coupler is at its normal towing height. Refer to the Load Capacity Ratings Chart of this manual for tongue weight information.

Always maintain a slow speed when trailering and towing, and avoid sudden accelerations, quick maneuvers, and sudden stops. Braking distance will be affected when towing a trailer. When towing a trailer, always maintain slow speed and allow for more stopping distance than when not towing a trailer.



WARNING

Riding your ATV while towing a trailer requires extreme caution or the activity will be hazardous. Trailer towing will affect the handling and braking of your ATV. You should only tow at low speeds and never exceed 10 MPH. Avoid sudden accelerations and stopping. Do not make quick maneuvers. Avoid uneven surfaces and do not tow on hills. Never carry passengers in a trailer unless the trailer is designed for use and has a rigid tow bar. Allow for more stopping distance when towing a trailer.

Getting To Know Your ATV

Transporting Your ATV

When transporting your ATV, ARGO recommends to set the ATV in its normal operating position (level, on all four wheels) and use the following procedure:

1. Engage the parking brake and place the transmission in forward gear.
2. Secure the ATV with hold-down straps rated to hold a load in excess of the weight of your ATV.

NOTE: Suitable hold-down straps are available from your ARGO ATV dealer. Ordinary rope is not recommended because it will stretch under load.



CAUTION

When attaching hold-down straps, care must be taken not to damage the ATV.

When transporting the ATV, make sure the parking brake (brake lever lock) is engaged, the transmission is in forward gear, and the ATV is properly secured.

Getting To Know Your ATV

WHAT TO DO IF

This section is designed to be a reference guide only. Be sure to read each section on riding techniques completely.

WHAT TO DO....

If your ATV doesn't turn when you want it to:

Bring the ATV to a stop and practice the turning maneuvers again. Be sure you are putting your weight on the footboard to the outside of the turn. Position your weight over the front wheels for better control.

If your ATV begins to tip while turning:

Lean more into the turn to regain balance. If necessary, gradually let off the throttle and /or steer to the outside of the turn.

If your ATV starts to slide sideways:

Steer in the direction of the slide if you have the room.

Applying the brakes or accelerating is not recommended until you have corrected the slide.

If your ATV can't make it up a hill you are trying to climb:

Turn the ATV around if you still have forward speed. If not, stop, dismount on the uphill side of the ATV and physically turn the ATV around. If the ATV starts to slip backwards DO NOT USE THE REAR BRAKE - the ATV may tip over on top of you. Dismount the ATV on the uphill side.

If your ATV is traversing a sloping surface:

Be sure to ride with your weight positioned towards the uphill side of the ATV to maintain proper balance. If the ATV starts to tip, steer down the hill (if there are no obstacles in your way) to regain balance. If you discover that the ATV is going to tip over, dismount on the uphill side.

If your ATV encounters shallow water:

Ride slowly and carefully through slow moving water, watching for obstacles. Be sure to let water drain from the ATV and CHECK YOUR BRAKES FOR PROPER OPERATION when you come out of the water. Do not continue to ride your ATV until you have regained adequate braking ability.

SECTION 6

Before You Ride

Engine Break-In

There is never a more important period in the life of your ATV than the first 10 hours of operation. Always use a light throttle, keeping engine RPM well below the maximum. Varying the engine RPM during the break-in period allows the engine and transmission components to mate together so they will operate smoothly in the future. Applying some higher engine RPM and other loads during the break-in period is not detrimental when done in moderation. Do not pull a trailer or haul heavy cargo during the break-in period.

When the engine starts, allow it to warm up properly. Permit the engine to idle for several minutes until it has reached normal operating temperature. However, do not allow the engine to idle for excessively long periods of time, as this additional heat can affect future engine integrity.



CAUTION

BRAKE PADS MUST BE BURNISHED TO ACHIEVE FULL BRAKING EFFECTIVENESS.

Braking distance will be greater until the brake pads are properly burnished.

To properly burnish the brakes, use the following procedure:

1. Choose an area sufficient to safely accelerate to 30 mph and smoothly brake to a stop.
2. Accelerate to 30 mph, then compress the brake lever to decelerate to 0-5 mph.
3. Repeat procedure 10 times.
4. Stop the vehicle and allow the brake pads to cool to ambient temperature.



WARNING

Do not attempt sudden stops or put yourself into a situation with your ATV where a sudden stop will be required until the brake pads are properly burnished.

After the completion of the break-in period, your ATVs engine oil and filter should be changed. Other maintenance after break-in should include checking all prescribed adjustments and tightening all fasteners. It is your responsibility as the owner and rider of your ATV to arrange for and pay for this initial service.

Because of the technical ability and resources available at an authorized ARGO dealer, it is best to take your ATV to the dealer for service rather than attempting to perform this initial service yourself.

Pre-Operation Checks

Inspect your vehicle each time you use it to make sure the vehicle is in safe operating condition.

Always follow the inspection and maintenance procedures and schedules described in your Owner's Manual.



WARNING

Failure to inspect or maintain the vehicle properly increase the possibility of an accident or equipment damage. Do not operate the vehicle if you find any problem. If a problem cannot be corrected by the procedures provided in this manual, have the vehicle inspected by the dealer.

Operation - Before You Ride

Before operating this ATV, check the following points:

ITEM	ROUTINE
Fuel	<ul style="list-style-type: none">• Check fuel level in fuel tank and add recommended fuel if necessary.• Check fuel line for leakage. Correct if necessary.
Engine Oil	<ul style="list-style-type: none">• Check oil level in engine and add recommended oil to specified level if necessary.• Check ATV for oil leakage. Correct if necessary.
Differential/Rear Drive Gear Oil	<ul style="list-style-type: none">• Check ATV for oil leakage. Correct if necessary.
Brakes	<ul style="list-style-type: none">• Lubricate cables if necessary.• Check lever free play and adjust if necessary.• Check operation, if soft or spongy, have the dealer bleed the hydraulic system.• Check brake pads for wear and replace if necessary.• Check brake fluid level in reservoir and add recommended brake fluid to specified level if necessary.• Check hydraulic system for leakage. Correct if necessary.
Throttle Lever	<ul style="list-style-type: none">• Ensure smooth operation. Lubricate cable and lever housing if necessary.• Check lever free play and adjust if necessary.
Control Cables	<ul style="list-style-type: none">• Ensure smooth operation. Lubricate if necessary.
Wheels and Tires	<ul style="list-style-type: none">• Check wheel condition and replace if damaged.• Check tire condition and tread depth. Replace if necessary.• Check air pressure. Correct if necessary.
Brake Levers	<ul style="list-style-type: none">• Ensure smooth operation. Lubricate lever pivoting point if necessary.
Chassis Fasteners	<ul style="list-style-type: none">• Ensure all nuts, bolts and screws are properly secured.
Instruments, Lights and Switches	<ul style="list-style-type: none">• Check operation and correct if necessary.

Operation - Before You Ride

Front and Rear Hydraulic Brakes

1. Hand Brake Lever and Foot Pedal

Make sure there is no brake fluid leakage.

Check operation of the levers. They should move smoothly and there should be a firm feeling when the brake is applied. If not, have the ATV inspected by an authorized ARGO dealer.

2. Brake operation

Test the brakes at slow speed after starting out to make sure they are working properly. If the brakes do not provide proper braking performance, inspect the brakes for wear.



WARNING

POTENTIAL HAZARD

Riding with improperly operating brakes.

WHAT CAN HAPPEN

You could lose braking ability, which could lead to an accident.

HOW TO AVOID THE HAZARD

Always check the brakes at the start of every ride. Do not ride the ATV if you find any problem with the brakes. If a problem cannot be corrected by the adjustment procedures provided in this manual, have the ATV inspected by an authorized ARGO dealer.

Fuel

Fill the fuel tank when necessary and make sure there is sufficient gasoline in the tank.

Check for leaks.

Fuel level should be below the filler neck.

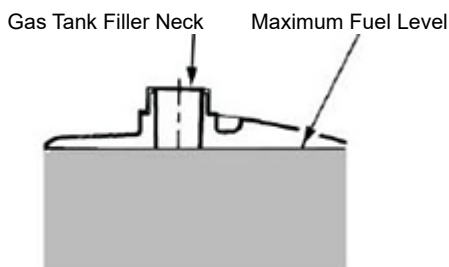

Recommended Fuel

87 minimum octane rating

Capacity:

4.0 gal (15 L)

Your ARGO engine has been designed to use regular unleaded gasoline with a pump octane number of 87 or higher. In many areas, oxygenates (either ethanol or MTBE) are added to the gasoline. Oxygenated gasolines containing up to 10% ethanol, 5% methane, or MTBE are acceptable fuel. If knocking or pinging occurs, use a different brand of gasoline or premium unleaded fuel. Unleaded fuel will give you longer spark plug life and reduced maintenance cost.

Use unleaded fuel only because it produces fewer engine and spark plug deposits and extends the life of the exhaust system. Never use stale or contaminated gasoline or an oil/gasoline mixture. Avoid getting dirt, dust or water in the fuel tank.

Operation - Before You Ride



WARNING

POTENTIAL HAZARD

Improper care when refueling.

WHAT CAN HAPPEN

Fuel can spill, which can cause a fire and severe injury.

HOW TO AVOID THE HAZARD

Do not overfill the fuel tank. Be careful not to spill fuel, especially on the engine or exhaust pipe. Wipe up any spilled fuel immediately. Be sure the fuel tank cap is closed securely. Do not refuel immediately after the engine has been running and is still very hot.

Engine Coolant Reservoir

Coolant absorbs heat from the engine and transfers it to the air at the radiator. If the coolant level becomes low, the engine overheats and may suffer damage. Check the coolant level each day before operating the ATV, and replenish coolant if the level is low. Change the coolant in accordance with the Maintenance Schedule.

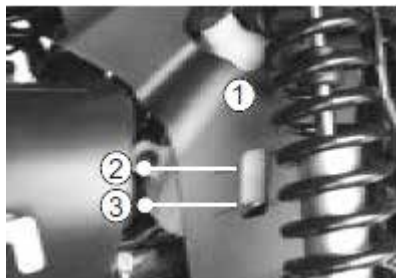

1. Reserve Tank
2. "F" (Full) Mark
3. "L" (Low) Mark

Coolant Level Inspection

1. Position the ATV on level ground.
2. Check the coolant level through the coolant level window on the reserve tank when the engine is cold as the coolant level will vary with the engine temperature. The coolant level should be between the "F" (Full) and "L" (low) marks.
3. If the coolant level is low, remove the cap from the reserve tank and add coolant or distilled water through the filler opening to the "F" (Full) mark. Install the cap.

NOTE: If water is added, have an authorized ARGO dealer check the antifreeze content of the coolant as soon as possible.

The radiator fan operation is completely automatic. It is switched on or off according to the coolant temperature in the radiator.



CAUTION

Hard water or salt water is harmful to the engine. You may use distilled water if soft water is not available.

Operation - Before You Ride

Engine Oil

Make sure the engine oil is at the specified level. Add oil as necessary. Check for any leaks.

Recommended engine oil

classification: API Service SJ type or higher. The recommended oil viscosity is SAE 5W-30. Ambient temperature should determine the correct weight of oil. See the viscosity chart or consult an authorized ARGO dealer for guidance.

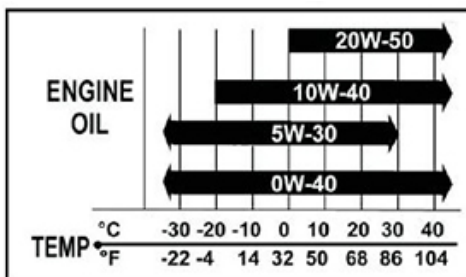

CAUTION

Be sure to use motor oils that do not contain anti-friction modifiers. Passenger car motor oils (often labeled “Energy Conserving”) contain anti-friction additives which will cause starter clutch slipping, resulting in reduced component life and poor engine performance.

Oil Level Inspection

There is an oil level stick (dip stick) on the left side of the engine for checking the engine oil level. To check the oil level follow the below procedure.

NOTE: The ATV should be parked on level ground, with the engine key switch in the “OFF” position.

1. Unscrew the oil level stick, remove it and wipe it with a clean cloth.
2. Reinstall the oil level stick, thread it into the engine case.
3. Unscrew the oil level stick and visually note the oil level on the stick. The engine oil level should be above the “L” mark but not higher than the “F” mark. Add or remove oil as required.

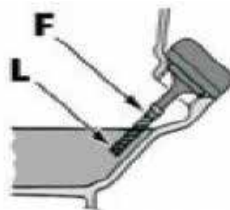

CAUTION

Do not overfill the engine with oil. Overfilling the engine can cause oil leaks and/or oil contamination of the air filter element. Always make sure the oil level is above the “L” mark but not higher than the “F” mark.

Operation - Before You Ride

Front Differential / Rear Drive

Recommended Lubricant: SAE 80W-90 Hypoid



CAUTION

Any lubricant used in place of the recommended lubricant may cause serious damage.

NOTE: The ATV should be parked on level ground, with the engine key switch in the "OFF" position.

1. Remove the oil level check bolt (1).
2. Ensure oil level reaches the oil level check hole.
3. Inspect O-ring for damage. Replace if necessary.
4. Install the oil level check bolt. Tighten to 7.2 ft lb (10 N-m).

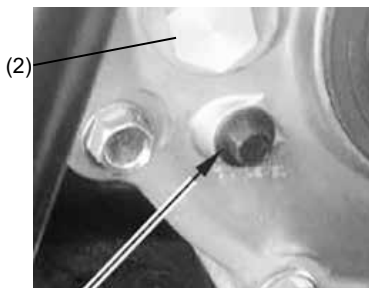

(1)

1. Oil Level Check Bolt
2. Oil Fill Bolt



CAUTION

Ensure no foreign material enters the gear case.

To add front gear case oil:

1. Remove the oil fill bolt (2).
2. Remove the oil level check bolt (1).
3. Ensure oil level reaches the oil level check hole.
4. Add appropriate type and amount of oil.
5. Inspect O-ring for damage. Replace if necessary.
6. Install the oil fill bolt and the oil level check bolt. Tighten oil fill bolt to 11 ft lb (15 N-m). Tighten the oil level check bolt to 7.2 ft lb (10 N-m).

Throttle Lever

Check to see that the throttle lever operates correctly. Throttle must open smoothly and spring back to the idle position when released. Adjust as necessary for proper operation.

Fittings and Fasteners

Always check chassis fittings and fasteners to ensure they are tight and secure. Take the ATV to an authorized ARGO dealer or refer to the Service Manual for correct torque specifications.

Lights

Check the headlight, taillight and brakelight to ensure they are in proper operating condition. Repair as necessary for proper operation.

Switches

Check the operation of the headlight switch, emergency stop switch and any other switches. Repair as necessary for proper operation.

Operation - Before You Ride

Tires

1. The tires listed below have been approved by ARGO for this model. Other tire combinations are not recommended.

How to Measure Tire Pressure

Use the low-pressure tire gauge found in the tool kit.

NOTE: The low-pressure tire gauge is included as standard equipment. Make two measurements of the tire pressure and use the second reading. Dust or dirt in the gauge could cause the first reading to be incorrect.



WARNING

POTENTIAL HAZARD

Operating this ATV with improper tires, or with improper or uneven tire pressure.

WHAT CAN HAPPEN

Use of improper tires on this ATV, or operation of this ATV with improper or uneven tire pressure, may cause loss of control, increasing the risk of an accident.

HOW TO AVOID THE HAZARD

Follow the recommended tire pressures above.

Set tire pressure to the following (tires cold):

Recommended Tire Pressure:

Front - 4.0 psi (27.6 kPa)

Rear - 4.0 psi (27.6 kPa)



1. Low-pressure tire gauge

Tire Wear Limit

When the tire groove decreases to 1/8 in (3 mm) due to wear, replace the tire.

A. 1/8 in (3 mm)

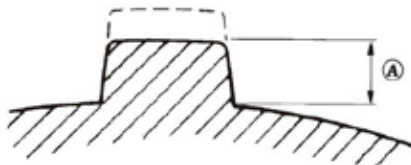

WARNING

POTENTIAL HAZARD

Operating this ATV without being familiar with all controls and functions.

WHAT CAN HAPPEN

Loss of control, increasing the risk of an accident or injury.

HOW TO AVOID THE HAZARD

Read the Owner's Manual carefully. If there is a control or function you do not understand, contact an authorized ARGO dealer.

SECTION 7

Operation

Always wear the following to reduce risk of injury in an accident:

- Approved motorcycle helmet that fits properly.
- Eye protection (goggles, helmet face shield or protective eyewear)
- Over the ankle boots, gloves, long sleeved shirt or jacket and long pants.

An approved helmet and other personal protective equipment can reduce the severity of injuries in an accident.



WARNING

Operating without an approved motorcycle helmet increases your chances of a severe head injury or death in the event of an accident.

Wear eye protection when operating your ATV to reduce the risk of a serious accident or injury. Eye protection such as a face shield or goggles may reduce the risk of foreign material getting in your eyes and help prevent loss of vision.



WARNING

Operating without eye protection can result in an accident and increases your chances of a severe injury in the event of an accident.

Mounting the ATV

1. From the left side, grasp the left-side handlebar, apply the left-side hand brake, and put your left foot on the footrest.
2. Grasp the right-side handlebar.
3. Swing your right leg over the seat and position your right foot on the right-side footrest.
4. Position yourself on the seat.



CAUTION

Note the position of your right foot so it is not resting or applying pressure to the rear foot brake. Premature brake failure may occur.

5. Always keep your feet positioned in the footrests and hands on the handlebars.

Starting the Engine

Always start the engine with the ATV on a flat, level surface. Always start your ATV outside as it produces carbon monoxide poisoning which will cause harm. Follow these steps to start your ATV:

1. Engage the parking brake lock on the left-side handlebar.
2. Turn the emergency stop switch to the "RUN" position.
3. Rotate the ignition switch key to the "ON" position.
4. Shift ATV into the "N" (Neutral) position.

NOTE: The engine can be started in any gear if the brake lever is applied. However, it is recommended to shift into "N" (Neutral) before starting the engine. If either indicator light fails to illuminate when the gear select lever is in the neutral or park position, have an ARGO dealer inspect the electrical circuit.

Operation

5. Depress the starter button.



CAUTION

Do not run the starter motor for more than 5 (five) seconds per starting attempt as the starter motor may overheat causing severe damage. Allow 10 (ten) seconds between starting attempts to allow the starter motor to cool. Pay attention not to discharge the battery.

NOTE: If the battery voltage is low, engine cannot be started. Properly charge the battery.

6. Do not depress the throttle lever until the engine has reached operating temperature.
7. Allow the engine to properly warm up. If the engine has not reached proper operating temperature, the spark plug may not have reached a high enough temperature to burn off the excess fuel in the combustion chamber.

Warming Up Engine

To get maximum engine life, always warm up the engine. Never accelerate hard with a cold engine!



CAUTION

- Do not operate the throttle (open and close rapidly) as the ATV may move forward suddenly, causing possible loss of control.
- Do not leave the ATV unattended while the engine is warming up.

Braking / Stopping

Always allow plenty of room and time to stop your ATV safely. Be alert and prepared, as sometimes quick stops are inevitable. Whether you are stopping slowly or stopping quickly, follow these braking guidelines:

1. Squeeze the brake lever on the left handlebar to apply both the front and rear brakes or depress the foot brake to apply rear brakes.
2. If your wheels lock, release the brake lever or foot brake, then apply the brakes again.
3. Avoid prolonged application of the brakes. Even maintaining minimal pressure on the brake lever will cause the brake pads to drag on the brake rotor and may cause overheating of the brake fluid.



WARNING

Prolonged and repetitive use of the ATVs hydraulic brake for high speed stops will cause overheating of the brake fluid and premature brake pad wear which can cause unexpected loss of braking ability. Note the position of your right foot so it is not resting or applying pressure to the rear foot brake. Premature brake failure may occur.

Operation



WARNING

Use only ARGO approved brake fluid. Never substitute or mix different types or grades of brake fluid, as unexpected loss of braking ability can result. Check the ATVs brake fluid level and pad wear before each use. The loss of braking ability can result in severe injury or even death.

Transmission Ranges

This ATV is equipped with an automatic, dual-range transmission with reverse capability. To shift your ATV into the different drive ranges, follow the below steps.

To properly change transmission range:

1. Apply brake.
2. Move shift lever to the desired range.
3. Release brake.

NOTE: The HIGH range is for normal riding conditions with light loads. The LOW range is for carrying heavy loads, slow speeds or trailer towing. LOW range position provides slower speed and greater torque to the wheels.



Low Range High Range Neutral Reverse



CAUTION

Always shift the transmission into LOW range when operating on wet or uneven terrain, when towing or pushing heavy loads, or when using a plow. Failure to follow this caution may result in premature V-belt failure or other damage to the drive system.



CAUTION

Never shift the transmission while your ATV is in motion. Should your ATV be on a surface that is not level, engage the parking brake lock before shifting into another gear or into reverse.



WARNING

Do not start the engine or operate your ATV with the clutch shield removed. Severe injury could result.

Operation

Parking

Parking requires following the previous rules of braking; then:

1. When the ATV comes to a complete stop, shift ATV into the neutral “N” position.
2. Stop the engine using the emergency stop switch located on the handlebar.
3. Turn the ignition switch to the “OFF” position.
4. Always try to park your ATV on level ground. If you have to park on a hill, shift the ATVs transmission into low gear.
5. Engage the parking brake lock.

Dismounting the ATV

1. Double-check that the parking brake lock is engaged.
2. Swing your right leg over to the left side of the seat.
3. Step to the ground on the left side of the ATV.

SECTION 8

General Maintenance

NOTE: Proper maintenance of the ATV is extremely important for the safe operation and optimum performance. Follow the Maintenance Schedule and all ensuing maintenance instructions/information.

Inspection, adjustment and lubrication will keep your vehicle in the safest and most efficient condition possible.

Safety is an obligation of the vehicle owner/operator.



WARNING

Failure to properly maintain the vehicle may increase your risk of injury or death during service or while using the vehicle. If you are not familiar with vehicle service, have a dealer perform the service.



WARNING

Turn off the engine when performing maintenance unless otherwise specified.

- A running engine has moving parts that can catch on body parts or clothing and electrical parts that can cause shocks or fires.
- Running the engine while servicing can lead to eye injury, burns, fire or carbon monoxide poisoning or death.



WARNING

Brake discs, calipers, drums and linings can become very hot during use. To avoid possible burns, let brake components cool before touching them.

The intervals given in the scheduled maintenance charts should apply to normal riding conditions. However, **depending on the weather, terrain, geographical location and individual use, the maintenance intervals may need to be shortened.**

You may choose any qualified repair shop or person to maintain, replace, or repair emission control devices and systems with original or equivalent replacement parts. However, warranty, recall and all other services paid for by ARGO must be performed at an authorized ARGO service center which will complete repairs in a reasonable amount of time. ARGO service centers can provide all manner of service.

Ensure the service book is stamped and signed. Failure to do so could invalidate your warranty.

The maintenance schedule is based on months of use or kilometers/miles traveled, whichever comes first.

Maintenance Schedule

Item	Initial 100 miles/150 Km 1 month	Every 600 miles/1000 Km 6 months	Every 1200 miles/2000 Km 12 months
Engine oil	R	R	
*Oil strainer	C,R	C,R	C,R
Engine oil filter	R	R	
Rear gear oil	R	E	I,R
Front differential gear oil	R	E	I,R
Air filter element (for engine and *V-belt compartment)	E	I,R	I,R
*Throttle body			I
*Cylinder head cover breather system		I,R	I,R
Spark plug	I,R	I,R	I,R
*Fuel line		I,R	I,R
*Valve adjustment	I	I	I
*Brake	I,R	I,R	I,R
*Coolant	I,R	I,R	I,R
*V-belt	I,R		I,R
*Exhaust system		I,T,R	I,T,R
Spark arrester		I	I
Tires/*Wheels	I,R	I,R	I,R
*Wheel bearings	I,R	I,R	I,R
*Steering system	I,R	I,R	I,R
*Drive shaft boots		I,R	I,R
*Suspension		I	I
Throttle cable, brake lever pivot points, steering shaft		L	L
*Fittings, fasteners and nuts	I	I	I
Lug nuts	T	T	T

I = Inspect, clean, adjust, lubricate, replace as necessary

C = Clean

L = Lubricate

R = Replace

T = Tighten

E = Extreme Conditions

***** = Dealer Maintenance

General Maintenance

Radiator

The radiator area requires to be checked periodically for debris. Inspect the radiator fins, they must be clean, free of mud, dirt, leaves and any other debris that would prevent the radiator to cool properly. Remove as much of the debris as possible with your hands. If water is available, use a low pressure to rinse the radiating fins. Do not use high pressure as it will damage the radiator.



CAUTION

Never clean radiator with your hands when engine is hot. Let the radiator cool down before cleaning.

Do not use high pressure water to clean radiator, damage may occur.

Shock Absorbers

Each shock absorber on your ATV should be visibly inspected weekly for excessive fluid leakage (some seal leakage is normal), cracks or breaks in the shock body, or a bent shock rod. If any of these conditions are present, replacement is necessary.

NOTE: If you ride your ATV in extremely cold weather (-10° F/-23° C or colder), a small amount of fluid leakage may occur on the shock rod. Unless the leakage is excessive, replacement of the shock absorbers is not necessary.

The shock absorbers have spring force adjustment sleeves with five positions to allow the spring rate to be adjusted for different riding conditions. If the spring rate is too soft or too stiff, adjust the sleeve according to the chart below.

NOTE: Properly lift the ATV off the ground to remove load on suspension before adjusting shock springs. Use a spanner wrench to adjust the spring force adjustment sleeve to the desired position.



Position	Spring Force	Setting	Load
1	↓ Stronger	Soft	Light
2		↕ Stiff	↕ Heavy
3			
4			
5			

General Maintenance

General Lubrication

Cables

Under normal use, the cables do not require lubrication. However, it is advisable to lubricate the ends of the cables periodically with a quality cable lubricant.

Engine Oil Level Inspection

NOTE: The ATV should be parked on level ground, with the engine key switch in the “OFF” position.

1. Remove the oil level stick and wipe it off with a clean cloth.
2. Insert the oil level stick into the filler hole without screwing it in.
3. Remove the oil level stick and inspect the oil level.
4. The oil level should be between the minimum and maximum marks. If the level is low, add oil to the proper level.
5. Reinstall oil level stick and tighten securely.

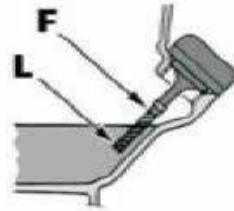

CAUTION

Do not overfill the engine with oil. Overfilling the engine can cause oil leaks and/or oil contamination of the air filter element. Always make sure the oil level is above the “L” mark but not higher than the “F” mark.

Engine Oil and Oil Filter Change

NOTE: The ATV should be parked on level ground, with the engine key switch in the “OFF” position.

Change the ATV engine oil and oil filter at the scheduled intervals. The engine should always be warm when the oil is changed so the oil will drain easily and completely.

1. Park the ATV on level ground.



CAUTION

Ensure no foreign material enters the crankcase.

General Maintenance

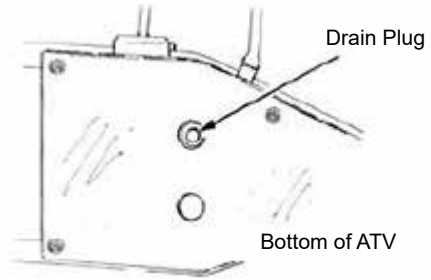

2. Warm up the engine for several minutes and stop the engine.
3. Place a suitable drain pan under the ATV.
4. Remove the drain plug from the bottom of the engine and drain the oil into the drain pan. Account for the sealing washer.
5. Remove the oil level stick.
6. Using an oil filter wrench, remove the oil filter and dispose of it properly. Do not reuse the oil filter.

NOTE: Clean up any excess or spilled oil after removing the oil filter.

7. Apply a thin coating of new oil to the O-ring gasket on the new oil filter. Ensure the O-ring is positioned correctly, then install the new oil filter. Tighten securely.
8. Install a new sealing washer and install the engine oil drain plug. Tighten to 11 ft lb.
9. Pour the recommended amount and type of engine oil into the oil filler hole. Install the filler plug.
10. Start the engine (while the ATV is outside on level ground) and allow it to idle for a few minutes.
11. Turn the engine "OFF" and wait approximately one minute. Recheck the oil level and adjust as necessary.
12. Inspect the area around the drain plug and oil filter for leaks.

NOTE: Dispose of the used oil and filter in an environmentally proper way.



General Maintenance

Front Gear Case Oil Inspection

Inspect the gear lubricants in your ATV according to the Maintenance Schedule. When checking the lubricant, if low, use only the approved SAE 80W-90 hypoid type fluid and use the following procedure:

1. Park the ATV on level ground.
2. Remove the front differential level plug.

NOTE: If the gear case has a level plug, fluid level should be up to the threads of the level plug. If your ATVs gear case only has a fill plug, add fluid to within 1 inch of the threads of the fill plug.

3. Install the level plug and tighten securely.

Rear Gear Case Oil Inspection

Inspect the gear lubricants in your ATV according to the Maintenance Schedule. When checking the lubricant, if low, use only the approved SAE 80W-90 hypoid type fluid and use the following procedure:

1. Park the ATV on level ground.
2. Remove the rear drive fill / level plug.

NOTE: Fluid level should be up to the threads of the level plug.

3. Install the level plug and tighten securely.

Front and Rear Gear Case Oil (Inspection/Change)

Inspect and change the gear lubricants in your ATV according to the Maintenance Schedule. When changing the lubricant, only use the approved SAE 80W-90 hypoid type fluid and use the following procedure:

1. Park the ATV on level ground.
2. Place a suitable drain pan under the front differential drain plug.
3. Remove front differential drain plug (1) and drain the fluid into the pan.
4. Place the drain pan under the rear drive drain plug (2) and drain the fluid into the pan.



CAUTION

Inspect the oil for any signs of metal filings or water. If either are present, take your ATV to an authorized ARGO dealer for service.

General Maintenance

5. After all the fluid has been drained, reinstall the drain plugs. Tighten securely.
6. Pour recommended amount and type of oil into each filler hole.

NOTE: If the gear case has a level plug, add fluid up to the threads of the level plug. If your ATVs gear case only has a fill plug, add fluid to within 1 inch of the threads of the fill plug.



7. Reinstall the fluid filler plug and level plugs. Tighten securely.

Brake Hoses

Carefully inspect the hydraulic hoses for cracks or other visible damage. If damage is found, take the ATV to an authorized ARGO dealer for service.

Hydraulic Brakes



WARNING

Be sure to inspect the hydraulic brake system before every use. Always maintain the brakes and the brake fluid level according to the Maintenance Schedule.



Parking brake lock

Brake lever

General Maintenance

Brake Fluid

Check the brake fluid level in the brake fluid reservoir sight glass. If the level in the reservoir is below the lower level or not visible in the sight glass, add DOT 4 brake fluid.

NOTE: If the sight glass appears dark, there is an insufficient amount of brake fluid in the reservoir.



Brake Fluid
Sight Window



CAUTION

Be careful not to spill any brake fluid when filling the brake fluid reservoir. Brake fluid can damage the finish of plastic components. Wipe up any spilled brake fluid immediately.

Parking Brake Lock

Ensure the parking brake lock functions properly and the brakes (when engaged) locks the wheels.

1. Squeeze the brake lever two or three times. (Front and rear brakes).
2. Compress and hold the brake lever.
3. Attempt to push the ATV forward and backward.

NOTE: The parking brake lock must lock the wheels. If not, take your ATV to an authorized ARGO dealer for service.

General Maintenance

Rear Foot Brake

The rear foot brake must be maintained periodically to remain fully functional.



WARNING

Be sure to inspect the rear brake system before every use. Maintain the brakes according to the Maintenance Schedule.

NOTE: The brake fluid reservoir is located on the right rear frame.

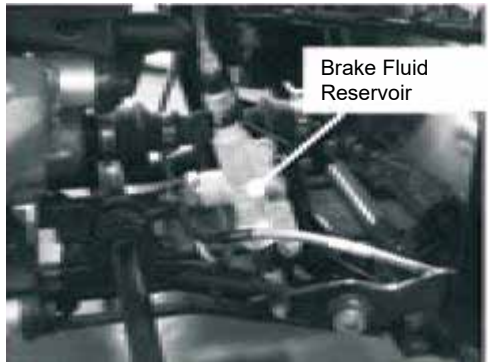

1. Press down on the rear brake pedal several times to check for firmness.
2. If the pedal response is not firm, the brake system must be bled.

NOTE: If the brake system requires bleeding, take your ATV to an authorized ARGO dealer for service.

Brake Pads

The clearance between the brake pads and brake discs is adjusted automatically as the brake pads wear. The only required maintenance is to replace brake pads when they become worn. To check the thickness of the brake pads, use the following procedure:

1. Park the ATV on level ground and engage the parking brake.
2. Loosen the wheel nuts on the front wheel to be removed. Do not remove the wheel nuts from the wheel studs.
3. Using a suitable jack, elevate the ATV. Support the ATV on a support stand.



WARNING

Ensure the ATV is safely supported on the stand to avoid injury.

4. Remove the wheel nuts.
5. Remove the wheel.
6. Measure the thickness of each brake pad. If the thickness of the pads are less than 0.039 in (1 mm), take your ATV to an authorized ARGO dealer to have the brake pads replaced.
7. Install the wheel and install wheel nuts.
8. Tighten in a crisscross pattern to 40 ft lb (54 N-m).
9. Remove the support stand and jack.

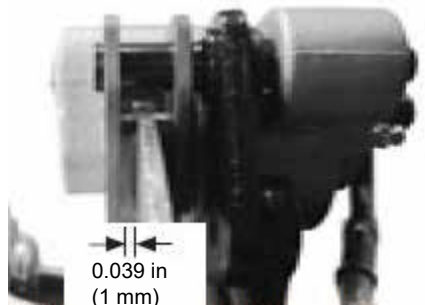

General Maintenance

Protective Rubber Boots

The protective rubber boots over the drive shafts should be inspected periodically per the Maintenance Schedule.

Ball Joint Boots (Upper/Lower and Left/Right)

1. Park the ATV on level ground and engage the parking brake.
2. Loosen the wheel nuts on the front wheels. Do not remove the wheel nuts from the wheel studs.
3. Using a suitable jack, elevate the ATV. Support the ATV on a support stand.



WARNING

Ensure the ATV is safely supported on the stand to avoid injury.

4. Remove the wheel nuts.
5. Remove the wheel.
6. Inspect the four ball joint boots for cracks, tears, perforations, or any other visible damage.
7. Check the ball joint for free-play by grasping the steering knuckle and turning it from side to side, and up and down.



8. If boot damage is noted or ball joint free-play seems excessive, contact an authorized ARGO dealer for service.
9. Install the wheel and reinstall the wheel nuts.
10. Tighten the wheel nuts in a criss-cross pattern to 40 ft lb (54 N-m).
11. Remove the support stand and jack.

Tie Rod Boots (Inner/Outer and Left/Right)

1. Park the ATV on level ground and engage the parking brake.
2. Loosen the wheel nuts on the front wheels. Do not remove the wheel nuts from the wheel studs.
3. Using a suitable jack, elevate the ATV. Support the ATV on a support stand.



WARNING

Ensure the ATV is safely supported on the stand to avoid injury.

4. Remove the wheel nuts.
5. Remove the wheel.

General Maintenance

6. Inspect the four tie rod boots for cracks, tears, perforations, or any other visible damage.
7. Check the tie rod end for free-play by grasping the tie rod near the end and attempting to move it up and down.
8. If boot damage is noted or tie rod end free-play seems excessive, contact an authorized ARGO dealer for service.
9. Install the wheel and reinstall the wheel nuts.
10. Tighten the wheel nuts in a criss-cross pattern to 40 ft lb (54 N-m).
11. Remove the support stand and jack.



Drive Axle Boots

1. Inspect all drive axle boots for cracks, tears, perforations, or any other visible damage.
2. If boot damage is noted, contact an authorized ARGO dealer for service.



General Maintenance

Wheel Removal

1. Park the ATV on level ground and engage the parking brake lock.
2. Loosen the wheel nuts on the wheel to be removed. Do not remove the wheel nuts from the wheel studs.
3. Using a suitable jack, elevate the ATV. Support the ATV on a support stand.



WARNING

Ensure the ATV is safely supported on the stand to avoid injury.

4. Remove the wheel nuts.
5. Remove the wheel.
6. Install the wheel and reinstall the wheel nuts.
7. Tighten the wheel nuts in a criss-cross pattern to 40 ft lb (54 N-m).
8. Remove the support stand and jack.

Wheel Installation

NOTE: When reinstalling a wheel, tighten the wheel nuts in a criss-cross pattern. Be sure the tapered side of the wheel nuts face the wheel rim.

1. Install the wheel and reinstall the wheel nuts.
2. Tighten the wheel nuts in a criss-cross pattern to 40 ft lb (54 N-m).
3. Remove the support stand and jack.

Front and Rear Wheel Nut Torque:
40 ft lb (54 N-m).

NOTE: The arrow mark on the tire must point in the rotating direction of the wheel.

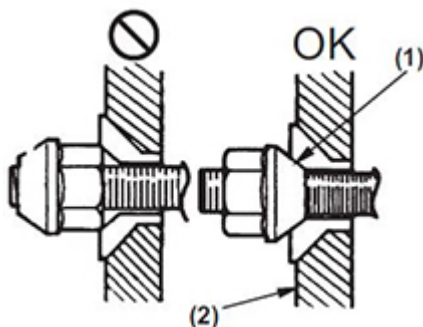

- (1) Wheel Nut
(2) Wheel Rim

Drive Select Lever Adjustment

1. Turn the ignition switch to the "ON" position and **DO NOT** start the engine.
2. Loosen the locknuts securing the shift rod. Move the drive select lever to the "N" (neutral) position by moving the shift lever and/or turn the shift rod. The "N" (neutral) indicator lamp should be illuminated. Tighten the locknuts securely.



General Maintenance

Battery

The battery is located under the right rear fender of your ATV. After initial service, batteries require regular cleaning and recharging in order to deliver peak performance and maximum service life. The procedures listed in this manual are recommended for cleaning and maintaining lead-acid batteries. Always read and follow instructions provided with battery chargers and battery products.

NOTE: You can perform your own battery maintenance if you are qualified to do so. If you do not feel qualified, take your ATV to an authorized ARGO dealer for battery service. As with all other periodic maintenance, you are responsible for any charges associated with these services.



WARNING

POTENTIAL HAZARD

Allowing open flames or sparks near the battery.

WHAT CAN HAPPEN

Gases may explode and possibly cause injury.

HOW TO AVOID THE HAZARD

Do not allow open flames or sparks near the battery.

NOTE:

- **When the ATV is to be stored for an extended period, remove the battery from the vehicle and charge it fully. Then store it in a cool, dry place. If the battery is to be left on the vehicle, disconnect the negative cable from the battery terminal.**
- **Battery posts, terminals and related accessories contain lead and lead compounds. Wash hands after handling.**

Battery Capacity:

1. Make sure the ignition switch is in the "OFF" position.
2. Remove the battery hold-down and then disconnect the battery cables.
3. Disconnect the negative (-) terminal lead from the battery first, then disconnect the positive (+) terminal lead.
4. Remove the battery from the battery compartment. Thoroughly wash the battery and the battery compartment with mild soap and water.

NOTE: If the battery posts, cable ends, or the battery case has a buildup of white/green powder residue, apply water and baking soda mixture to neutralize the acid residue and rinse with warm soapy water.

5. Use a wire brush to clean the battery posts and cable ends, remove all corrosive buildup. Replace any damaged cables.
6. Use a multimeter to test the battery voltage. The voltage for a fully charged battery should be at least 12.5 Volts DC.

NOTE: If the meter indicates the proper voltage, the battery can be reinstalled into the battery compartment of the ATV.

7. If the meter indicates low voltage, charge the battery using the guidelines below.

General Maintenance



WARNING

Any time service is performed on a battery, the following must be observed: keep sparks, open flame, cigarettes, or any other flame away. Always wear safety glasses. Protect skin and clothing when handling a battery. When servicing a battery in an enclosed space, keep the area well-ventilated. Make sure battery venting is not obstructed.

- A. When using an automatic battery charger, always follow the charger manufacturer's instructions.



CAUTION

Never exceed the battery's standard charging rate.



WARNING

An overheated battery from improper charging could explode causing severe injury or death. Always monitor charging times and charge rates carefully. Stop charging a battery if it becomes very warm to the touch. Allow it to cool before resuming any type of charging.



CAUTION

To avoid damage from the ATVs electronic fuel injection components, do not remove or install a battery wire when the ignition switch is in the "ON" position.

8. After charging the battery for the specified amount of time, remove the battery charger and allow the battery to sit and cool for 1 to 2 hours.
9. Test the battery voltage again after the battery has cooled. The meter should read at least 12.5 Volts DC. If the voltage is as specified, the battery is ready to be reinstalled into the battery compartment of the ATV.

NOTE: If the voltage in step 9 is below specifications, charge the battery an additional 1 - 5 hours and retest. If the voltage level is proper, then the battery can be reinstalled into the battery compartment of the ATV.

10. Reinstall the battery into the battery compartment of the ATV and apply a light coat of dielectric grease on the battery posts and cable ends.



CAUTION

Before installing the battery, ensure the ATVs ignition switch is in the "OFF" position.

11. Connect the battery cables (positive (+) cable first) and then the negative (-) cable.
12. Reattach the battery hold-down.



CAUTION

Connecting the battery cables in reverse (positive (+) to negative (-) and negative (-) to positive (+) can cause serious damage to the electrical system.

General Maintenance

Charging / Maintenance Charging

NOTE: ARGO recommends the use of a battery charger/maintainer. Maintenance charging is required on all batteries not used for more than two weeks or as required by battery drain.

1. When charging a battery in the vehicle, be sure the ignition switch is in the OFF position.
2. Clean the battery terminals with a solution of baking soda and water.

NOTE: The sealing strip should NOT be removed and NO fluid should be added.

3. Ensure the charger and battery are in a well-ventilated area and the charger is unplugged from the 110-volt electrical outlet.
4. Connect the red terminal lead from the charger to the positive (+) terminal of the battery; then connect the black terminal lead of the charger to the negative (-) terminal of the battery.
5. Plug the battery charger/maintainer into a 110-volt electrical outlet.
6. Follow charging instructions supplied with the charger/maintainer.

NOTE: Not using a battery charger with the proper float maintenance will damage the battery if connected over extended periods.

7. Once the battery has reached full charge, unplug the charger from the 110-volt electrical outlet.

NOTE: If, after charging, the battery does not perform to operator expectations, bring the battery to an authorized ARGO dealer for further troubleshooting.

Jump-Starting

NOTE: ARGO does not recommend jump-starting a vehicle with a dead battery but rather to remove the battery, service it, and correctly charge it.



WARNING

Improper handling or connecting of a battery may result in severe injury including acid burns, electrical burns, or blindness as a result of an explosion. Always remove rings and watches.



WARNING

Any time service is performed on a battery, the following must be observed: keep sparks, open flame, cigarettes, or any other flame away. Always wear safety glasses. Protect skin and clothing when handling a battery. When servicing battery in enclosed space, keep the area well-ventilated. Make sure battery venting is not obstructed.

General Maintenance

Spark Plug

Your ATV is equipped with a specific spark plug (see “Specifications” for the correct spark plug). The appearance of the insulator on a used spark plug will help determine if it is the proper one for your ATV.

A light brown insulator indicates that the spark plug is correct. A white or dark insulator indicates that the engine may need to be serviced or adjustments made. Consult an authorized ARGO dealer if the plug insulator is not a light brown color.

To help prevent cold weather fouling (a buildup of carbon and unburned fuel on the spark plug) make sure you thoroughly warm up your ATVs engine before riding.

Before inspecting a spark plug, clean the area around the spark plug to prevent any dirt from entering the engine when remove or installing the spark plug.

Adjust the spark plug’s ground electrode gap to 0.028 - 0.032 in. (0.7 - 0.8 mm). Use a wire-type feeler gauge to check the gap.

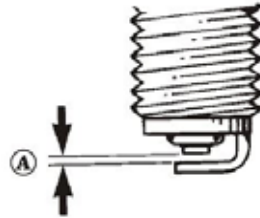

A. Spark plug gap

When installing a spark plug, be sure to tighten it securely. A new spark plug should be tightened 1/2 turn once the washer makes contact with the cylinder head. A used spark plug should be tightened 1/8 - 1/4 turn once the washer makes contact with the cylinder head.

Throttle Cable Adjustment

Follow this procedure to adjust throttle cable free-play:

1. Slide the rubber boot (2) back and loosen the jam nut (3) from the throttle cable adjuster.
2. Turn the adjuster (4) until the throttle lever has the proper free-play of 1/8 - 1/4 in. (3 - 6 mm).



3. Tighten the jam nut against the throttle cable adjuster securely and slide the rubber boot back over the adjuster.

General Maintenance

Air Filter

The air filter inside the air filter housing must be kept clean to provide good engine power, gas economy and to prevent premature engine wear. If you use your ATV under normal conditions, service the filter at the intervals specified. If you ride it in dusty, wet, or muddy conditions, inspect and service the filter more frequently. Use the following procedure to remove the filter and then inspect and clean it.

1. Rotate the three latches to release the filter housing cover, then loosen the inlet boot clamp.

Inlet Boot Clamp



WARNING

POTENTIAL HAZARD

Using low flash point solvents or gasoline to clean the air filter element.

WHAT CAN HAPPEN

Low flash point solvents or gasoline can catch fire or explode increasing the risk of an accident or injury.

HOW TO AVOID THE HAZARD

Use parts cleaning solvent to clean the air filter element.



CAUTION

Do not twist the air filter element when squeezing it.

2. Remove the filter housing cover and air filter. Note the orientation of the air filter. Closed end of the filter faces the air box lid and the open end of the air filter faces the intake of the air box.
3. Fill an adequately sized wash pan with a non-flammable solvent and wash the air filter clean of debris.
4. Squeeze the air filter by pressing it between the palms of both hands to remove excess solvent. Do not twist or ring-out the air filter or you may damage it.
5. Dry the air filter.
6. Place the air filter into a plastic bag, pour air filter oil into the bag and work the oil into the air filter.
7. Squeeze the air filter to remove the excess oil.

General Maintenance



CAUTION

A torn air filter can cause damage to your ATVs engine. Dirt or dust may get inside the engine if the air filter is torn. Carefully inspect the air filter for tears before and after cleaning it. Replace the air filter with a new one if it is torn or damaged in any way.

8. Clean any dirt or debris from inside the air cleaner. Be sure no dirt enters the carburetor.
9. Reinstall the air filter and cover.
10. Reconnect the inlet boot and tighten the clamp securely.

Air Filter Housing Drain

It is recommended to occasionally drain any fluid that has accumulated in your ATVs air filter housing. Do this using the rubber-flap drain valve located on the side of the housing. Squeeze the flap to allow fluid to drain from the housing. Inspect the drain to make sure it is not blocked with debris and it is sealing properly.



Draining the V-Belt Cover

NOTE: If the ATV has been driven through water, the V-Belt cover must be drained of any liquid.

1. Place the ATV on a flat, level surface.
2. Remove the drain bolt from the cover to allow liquid to drain out.
3. Position the shift lever to the neutral "N" position; then start the engine.
4. Increase and decrease the engine RPM several times to force out any additional liquid; then stop the engine.
5. Reinstall the drain bolt and tighten securely.

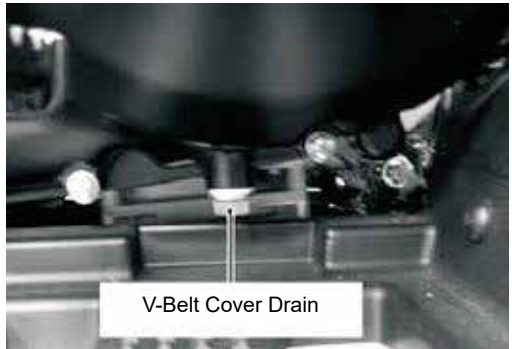

NOTE: The V-belt and pulleys should be inspected every 500 miles and the belt replaced when necessary.

General Maintenance

Tires



WARNING

Always use the size and type of tires specified for your ARGO ATV. Refer to the specifications chart in this manual for tire-related information and always maintain proper tire inflation pressure.

Tire Replacement

This ATV has low-pressure tubeless tires. Air is sealed by the contact surfaces of the inner rim and the tire bead. If either the inner rim or tire bead are damaged, air may leak. Be extremely careful not to damage these areas when replacing tires. It is very important to use the proper tools when repairing or replacing tires to prevent damage to the tire, the tire bead or the rims. If you do not have access to the proper tools or lack the technical ability, have your tires serviced by an authorized ARGO dealer.



WARNING

The use of worn-out tires on your ATV can be dangerous and can increase the risk of an accident.



CAUTION

When breaking the tire bead loose from the wheel, be extremely careful not to damage the inner wheel surface or the tire bead.



WARNING

Use only ARGO approved tires on your ATV when replacing tires. Failure to do so could result in unstable ATV operation.

General Maintenance

Muffler / Spark Arrester

The muffler on this ATV is equipped with a spark arrester which must be periodically cleaned. Refer to the intervals listed in the Maintenance Schedule and clean the spark arrester using the procedure listed below.



WARNING

Before service, wait for the muffler to properly cool to avoid possible burns.

1. Remove the cap screws (1) securing the spark arrester assembly to the muffler and then remove the spark arrester.
2. Using a suitable brush, clean the carbon deposits from the screen, taking care to not damage the screen.

NOTE: If the spark arrester screen or gasket is damaged in any way, they must be replaced.

3. Install the spark arrester assembly and secure with the cap screws. Tighten securely.

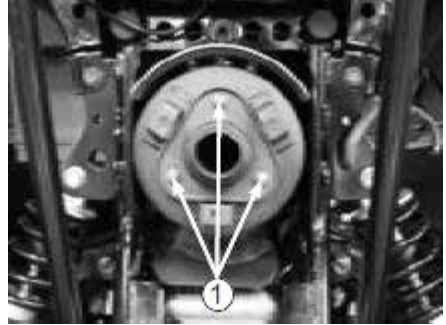

WARNING

POTENTIAL HAZARD

Improper cleaning of the spark arrester.

WHAT CAN HAPPEN

Could injure the eyes.

Could cause burns.

Could cause carbon monoxide poisoning, possible leading to death.

Could start a fire.

HOW TO AVOID THE HAZARD

When cleaning the spark arrester:

Always let the exhaust system cool prior to touching exhaust components.

Do not start the engine when cleaning the exhaust system.

Light Bulb Replacement

The wattage rating of each bulb is listed below. When replacing a burned out bulb, always use the same wattage rating.

Headlight 12V/35W

Taillight / Brakelight 12V/5W/21W



CAUTION

Use only bulbs that are specified in this manual as replacement bulbs on this ATV.

General Maintenance

Headlight

NOTE: The LED headlights are fragile and must be replaced as an assembly. HANDLE WITH CARE.

To replace the headlight, use the following procedure:

1. Ensure the ignition switch is in the "OFF" position.
2. Disconnect the wiring connector from the back of the headlight.
3. Remove the four screws securing the headlight housing to the grille.
4. Remove the two screws securing the headlight to the headlight housing.
5. To install, reverse the above procedure.



Running Lights

NOTE: The LED lights are fragile and must be replaced as an assembly. HANDLE WITH CARE.

To replace the running light, use the following procedure:

1. Ensure the ignition switch is in the "OFF" position.
2. Disconnect the wiring connector from the back of the running light.
3. Remove the screw securing the running light to the grille.
4. To install, reverse the above procedure.



General Maintenance

Taillight / Brakelight

To replace the taillight / brakelight bulb, use the following procedure:

1. Ensure the key switch is in the "OFF" position.
2. Rotate the socket counter-clockwise to remove the assembly from the housing.
3. To remove the bulb from the socket, gently push in and rotate the bulb counter-clockwise.
4. Install the new bulb by gently pushing in and rotate it clockwise.
5. Insert the socket into the housing and rotate it clockwise completely.

Checking / Adjusting Headlight Aim

Headlights can be adjusted vertically and horizontally. The projected center of the HIGH beam should be used for vertical and horizontal aiming.

1. Position the ATV on a flat, level surface so the headlights are approximately 20 ft (6.1 m) from a vertical aiming surface.

NOTE: There should be an average operating load on the ATV when adjusting the headlight aim.

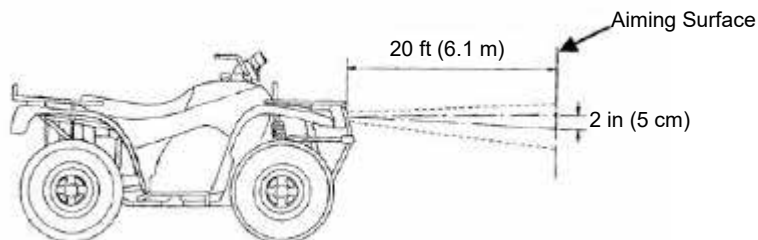

2. Measure the distance from the floor to the center of each headlight.
3. Using the measurements obtained in step 2, make horizontal marks on the aiming surface.
4. Make vertical marks that intersect the horizontal marks on the aiming surface directly in front of the headlights.
5. Switch the ATV lights to the "ON" position. Make sure the LOW beam switch is on. **DO NOT USE HIGH BEAM.**
6. Observe each headlight beam aim. Proper aim is achieved when the most intense beam is centered on the vertical mark 2 in (5 cm) below the horizontal mark on the aiming surface.
7. Adjust each headlight until you achieve the correct aim by turning the necessary adjustment screw clockwise or counter-clockwise. See Headlight Aim Adjuster.

General Maintenance

Headlamp Aim Adjuster

To raise or lower the headlight beam, turn the adjustment screw "IN" to raise the beam or "OUT" to lower the beam.



Fuses

The ATV fuses are located in a power distribution module in front of the steering post under the electrical access panel. If there is any type of electrical system failure, always check the fuses first.

NOTE: To remove a fuse, compress the locking tabs on either side of the fuse cover and lift it out.



CAUTION

Always replace a failed fuse with a fuse of the same type and rating. If the new fuse fails after a short period of use, consult an authorized ARGO dealer immediately.



WARNING

POTENTIAL HAZARD

Using an improper fuse.

WHAT CAN HAPPEN

An improper fuse can cause damage to the electrical system which could lead to a fire.

HOW TO AVOID THE HAZARD

Always use a fuse of the specified rating. Never use a material in place of the proper fuse.

General Maintenance

NOISE REGULATION

TAMPERING WITH NOISE CONTROL SYSTEM PROHIBITED:

Federal law prohibits the following acts or the causing thereof: (1) The removal or rendering inoperative by any person other than for purposes of maintenance, repair, or replacement of any device or element of design incorporated into any new vehicle for the purpose of noise control prior to its sale or delivery to the ultimate purchaser or while it is in use or (2) the use of the vehicle after such device or element of design has been removed or rendered inoperative by any person.

“AMONG THOSE ACTS PRESUMED TO CONSTITUTE TAMPERING ARE THE ACTS LISTED BELOW”.

These acts include tampering with the following systems; i.e., modification, removal, etc.

- Exhaust system: Muffler
Exhaust pipe
Silencer
- Intake system: Air cleaner case
Air cleaner element
Intake duct

Troubleshooting

Engine doesn't turn over

Possible Cause	Solution
Failed fuse	Replace the fuse
Low battery voltage	Recharge battery to 12.5 VDC
Loose battery connections	Check all connections and ignition
Loose solenoid connections	Check all connections and ignition

Engine turns over but fails to start

Possible Cause	Solution
Out of fuel	Refuel
Clogged fuel filter	Inspect, clean or replace
Water is present in fuel	Drain the fuel system and refuel
Fouled or defective spark plug	Inspect plug, replace if necessary
Crankcase filled with water or fuel	Immediately see your dealer
Low battery voltage	Recharge battery to 12.5 VDC
Mechanical failure	See your dealer

Engine pings or knocks

Possible Cause	Solution
Poor quality or low octane fuel	Replace with recommended fuel
Incorrect ignition timing	See your dealer
Incorrect spark plug gap or heat range	Set gap to specs or replace plug

Engine backfires

Possible Cause	Solution
Weak spark from spark plug	Inspect, clean and/or replace spark plug
Incorrect spark plug gap or heat range	Set gap to specs or replace plug
Old or non-recommended fuel	Replace with new fuel
Incorrectly installed spark plug wire	See your dealer
Incorrect ignition timing	See your dealer
Mechanical failure	See your dealer

Engine runs irregularly, stalls or misfires

Possible Cause	Solution
Fouled or defective spark plug	Inspect, clean and/or replace spark plug
Worn or defective spark plug wire	See your dealer
Incorrect spark plug gap or heat range	Set gap to specs or replace plug
Loose ignition connection	Check all connections and tighten
Water present in fuel	Replace with new fuel

Troubleshooting

Possible Cause	Solution
Possible lean mixture fuel cause	
Low or contaminated fuel	Add or change fuel, clean fuel system
Low octane fuel	Replace with recommended fuel
Possible rich mixture fuel cause	
Fuel is very high octane	Replace with lower octane fuel
Engine stops or loses power	
Possible Cause	Solution
Out of fuel	Refuel
Kinked or plugged fuel vent line	Inspect and replace
Water present in fuel	Replace with new fuel
Fouled or defective spark plug	Inspect, clean and/or replace spark plug
Worn or defective spark plug wire	See your dealer
Incorrect spark plug gap or heat range	Set gap to specs or replace plug
Loose ignition connection	Check all connections and tighten
Low battery voltage	Recharge battery to 12.5 VDC
Incorrect fuel	Replace with recommended fuel
Clogged air filter	Inspect, clean or replace
Other mechanical failure	See your dealer
Overheated engine	Clean engine exterior See your dealer

SECTION 9

Preparation For Storage



CAUTION

Prior to storing your ATV, it must be properly serviced to prevent rusting and component deterioration.

Cleaning the Vehicle

Frequent, thorough cleaning of your ATV will not only enhance its appearance but will improve its general performance and extend the useful life of many components.

1. Before cleaning the ATV:
 - a. Block off the end of the exhaust pipe to prevent water entry. A plastic bag and strong rubber band may be used.
 - b. Make sure the spark plug and all filler caps are properly installed.
2. If the engine case is excessively greasy, apply degreaser with a paintbrush. Do not apply degreaser to wheel axles.
3. Rinse the dirt and degreaser off with a garden hose. Use only enough pressure to do the job.



WARNING

- Wet brakes may have reduced stopping ability, increasing the chance of an accident. Test the brakes after washing. Apply the brakes several times at slow speeds to let friction dry out the linings.
- Excessive water pressure may cause water seepage and deterioration of wheel bearing, brakes, transmission seals and electrical devices. Many expensive repair bills have resulted from improper high-pressure detergent applications such as those available in coin-operated car washes.

4. Once most of the dirt has been hosed off, wash all surfaces with warm water and mild, detergent-type soap. An old toothbrush or bottle brush is handy for hard to reach places.
5. Rinse the ATV off immediately with clean water and dry all surfaces with a chamois, clean towel or soft absorbing cloth.
6. Clean the seat with vinyl upholstery cleaner to keep the cover pliable and glossy.
7. Automotive type wax may be applied to all painted and chrome plated surfaces. Avoid combination cleaner-waxes. Many contain abrasives, which may mar the paint or protective finish. When finished cleaning, start the engine and let it idle for several minutes.

Storage

Short Term

Always store your ATV in a cool, dry place and if necessary, protect it against dust with a porous cover.



WARNING

Storing the ATV in a poorly ventilated room or covering it with a tarp while it is still wet, will allow water and humidity to seep in and cause rust. To prevent corrosion, avoid damp cellars, stables and area where strong chemicals are stored.

Long Term

Before storing your ATV for several months:

1. Follow all the instructions in the “Cleaning” section of this chapter.
2. Fill up the fuel tank and add fuel stabilizer to prevent the fuel from deteriorating.
3. Perform the following steps to protect the cylinder, piston rings, etc. from corrosion.
 - a. Remove the spark plug cap and spark plug.
 - b. Pour a teaspoonful of engine oil into the spark plug bore.
 - c. Install the spark plug cap onto the spark plug and then place the spark plug on the cylinder head so that the electrodes are grounded.
 - d. Turn the engine over several times with the starter.
 - e. Remove the spark plug cap from the spark plug and then install the spark plug and the spark plug cap.
4. Lubricate all control cables and the pivoting points of all levers and pedals.
5. Check and if necessary, correct the tire air pressure and then block up the ATV so that all of its wheels are off the ground. Alternatively, turn the wheels a little every month in order to prevent the tires from becoming degraded in one spot.
6. Cover the muffler outlet with a plastic bag to prevent moisture from entering it.
7. Remove the battery and fully charge it. Store it in a cool, dry place and charge it once a month.

Do not store the battery in an excessively cold or warm place less than 32° F (0° C) or more than 86° F (30 C).

8. Make necessary repairs before storing the ATV.

SECTION 10

Warranty



LIMITED WARRANTY

Ontario Drive & Gear Limited (hereinafter "ARGO") extends a limited warranty on each new ARGO ATV, XTV, and SSV and on each genuine ARGO part and accessory sold by an authorized ARGO dealer. The limited warranty on an ARGO ATV, XTV, or SSV is provided to the original retail purchaser; however, the balance of the unused warranty may be transferred to another party through an ARGO dealer, but any such transfer will not extend the original term of the warranty. Warranty coverage is limited to the country in which the original retail purchase occurs and to the original retail purchaser resident in that country or, if transferred to a resident in that country for the balance of the remaining warranty.

The warranty is validated upon examination of said parts by ARGO or an authorized ARGO dealer. ARGO reserves the right to inspect such parts at its factory for final determination if warranty should apply. ARGO will repair or replace, at its option (including any related labor charges), any parts that are found to be warrantable in material or workmanship. This repair work must be done by an authorized ARGO dealer. No transportation charges, rental charges, or inconvenience costs will be paid by ARGO.

ARGO does not assume any liability for incidental or consequential damages.

WARRANTY COVERAGE PERIOD

1. Standard Warranty - 1 year from the date of sale.

Argo Promotional Extended Warranty provided at the time of sale will follow the Standard Warranty guidelines and coverage. Excludes batteries.

The warranty does not cover normal wear, abuse, or corrosion.

WARRANTY LIMITATIONS AND EXCLUSIONS

This ARGO limited warranty will become null and void if:

1. Failure to perform the proper break-in procedure and all related maintenance, storage procedures (if stored for extended periods), and/or service as recommended in the Operator's Manual.
2. Repairs and/or adjustments made by anyone other than an authorized ARGO dealer unless instructed by ARGO.
3. Any modification, addition, or removal of parts unless instructed to do so by ARGO.
4. Removal of the engine for use in another vehicle.
5. Use of improper fuels, lubricating oils, or spark plug(s).
6. Vehicle has been involved in an accident or subject to misuse, abuse, or negligent operation, including overloading.
7. Use of the vehicle in any way for racing purposes.
8. Removal or mutilation of the Product Identification Number or Engine Serial Number.
9. Damage due to improper transportation.
10. Use of aftermarket or unapproved parts, accessories or attachments not sold by ARGO.



11. Damage caused by Acts of God, such as storm damage, hail, lightning, and other environmental conditions.
12. Collision, fire, theft, freezing, vandalism, riot, explosion, or objects striking the vehicle.
13. Tampering with the vehicle's hour meter.

In consideration of the foregoing, any implied warranty is limited in duration to the warranty periods set forth. This warranty gives you specific legal rights, and you may also have other rights which vary from state/province to state/province and country to country. Some jurisdictions do not allow limitations on how long an implied warranty lasts, so the above limitations may not apply to you.

WARRANTY PROCEDURE / OWNER RESPONSIBILITY

At the time of sale, a Training Certificate (if applicable) or an Owner Registration form is to be completed by the selling dealer and consumer. The receipt of the form by ARGO is a condition precedent to warranty coverage. It is the selling dealer's responsibility to retain and/or submit appropriate electronic registration to initiate warranty coverage.

The selling dealer is responsible to furnish the consumer a signed copy of the form which must be presented to the dealer when requesting warranty service. The registration form is the consumer's proof of ownership and warranty eligibility. The form is to be used by the dealer to validate the warranty claim. Retain your copy of the Owner Registration form and keep it in a safe place.

When warranty repair is suspected, the vehicle should be taken to an authorized ARGO dealer, who has the primary responsibility to perform warranty repairs.

The authorized ARGO dealer will examine the vehicle or part to determine if a warrantable condition exists. If a warrantable condition appears to exist, the dealer will repair or replace, at ARGO's option, including any related labor costs, all parts that are found to be warrantable and any other parts which the warrantable part caused to be damaged.

It is the owner's responsibility to maintain and service the vehicle in accordance with ARGO's recommendations in the Operator's Manual. To protect yourself and your vehicle, follow all safety and service tips. ARGO will NOT warrant repairs required as a result of not performing standard operator maintenance, storage procedures, and service as outlined in the Operator's Manual.

Should you have any questions concerning the warranty, contact an authorized ARGO dealer.

EPA EMISSIONS CONTROL SYSTEM WARRANTY:

LIMITED WARRANTIES EMISSION CONTROL SYSTEMS:

ARGO warrants to the owner of any 2025 and subsequent model year ATV that the ATV is designed, built and equipped to conform at the time of sale with all applicable emission standards and is free from defects in materials and workmanship which would cause it to fail to conform with applicable requirements during the specified time and mileage limits.

A qualified repair shop or person of the owner's choosing may maintain, replace, or repair emission control devices and systems with original or equivalent replacement parts. However, warranty, recall and all other services paid or by ARGO must be performed at an authorized ARGO service center except in the emergency condition described below.

Your Warranty Rights and Obligations:

In the United States and Canada, new ATVs must be designed, built and equipped to meet stringent Federal anti-smog standards. ARGO must warrant the emissions control system on your ATV for the periods of time listed below, provided there has been no abuse, neglect or improper maintenance of your ATV. Your emissions control system may include parts such as the sensors, the ignition and the engine computer. Also included may be hoses, connectors and other emissions-related assemblies. Where a warrantable condition exists, ARGO will repair your ATV at no cost to you, including diagnosis, parts, and labor.

Owner's Responsibility:

As the ATV owner, you should also be aware that ARGO may deny you warranty coverage if your vehicle or a part has failed due to abuse, neglect, improper maintenance or unapproved modifications. If you have any questions regarding your warranty rights and responsibilities or if an authorized ARGO dealer cannot repair your ATV or honor your claim within a reasonable period of time, contact ARGO or assistance at 1-218-683- 5366. If you are not satisfied with the way in which a warranty claim is resolved by ARGO, you may write directly to:

Director, Gasoline Engine Compliance Center
Compliance Division
U.S. EPA
2000 Traverwood Drive
Ann Arbor, MI 48105

You must operate and maintain your ATV according to the requirements of the Owner's Manual including the maintenance schedule. This schedule is designed to keep your ATV emission control systems functioning properly and safely. You should keep receipts and records of maintenance and service but ARGO will not deny a warranty claim solely because of lack of maintenance records.

If an ARGO service center is not available within 100 miles, ARGO will reimburse you for those emergency repairs, including diagnosis, covered by the Emissions Warranties. Labor reimbursement is at a geographically-appropriate hourly labor rate for ARGO recommended time allowance. For reimbursement, present the replacement parts and a copy of the paid receipt to ARGO.

The use of replacement parts not equivalent to the original parts may impair the effectiveness of your ATV emissions control systems. If such a replacement part is used in the maintenance or repair of your ATV and an authorized ARGO dealer determines it is defective or caused a failure of a warranted part, your claim for repair to bring your ATV into compliance with applicable standards may be denied. If the part in question is not related to the reason your ATV fails to meet the standards, your claim will not be denied.

Emissions Warranty Coverage:

This warranty begins on the date the ATV is delivered to the first purchaser, or the date it is first used as a demonstrator, lease, or company ATV, whichever comes first and continues for the time and mileage listed below:

Time: 30 months OR

Mileage: 5,000 kilometers (3,100 miles) whichever comes first.

Warranted Parts:

Fuel Tank
Fuel Cap
Fuel Line
Fuel Line Fittings
Clamps*
Carburetor
Press. Relief Valves*
Control Valves*
Control Solenoids*
Electronic Controls*
Control Cables*
Control Linkages*
Purge Valves
Vapor Hoses
Liq/Vapor Separator
Air Intake System
Press Relief Fittings*
Vacuum Control Diaphragms*
Engine
Engine Electronic Control Module*
Ignition System*
Sensors*
Exhaust System and Components
Spark Arrestor
Fuel Injection System and Components

*Components that are part of the engine, fuel injection system, fuel evaporative system and emissions control system.

Maintenance Record

MAINTENANCE INTERVAL	DATE OF SERVICE	MILEAGE	SERVICING DEALER NAME AND ADDRESS	REMARKS
1 Month				
3 Months				
6 Months				
12 Months				
18 Months				
24 Months				
30 Months				
36 Months				
42 Months				
48 Months				
54 Months				
60 Months				



WARNING

Improper ATV use can result in SEVERE INJURY or DEATH.



**ALWAYS USE
AN APPROVED
HELMET AND
PROTECTIVE
GEAR**



**NEVER USE
ON PUBLIC
ROADS**



**NEVER CARRY
PASSENGERS**



**NEVER USE
WITH DRUGS
OR ALCOHOL**

NEVER operate:

- without proper training or instruction.
- at speeds too fast for your skills or the conditions.
- on public roads - a collision can occur with another vehicle.
- with a passenger - passengers affect balance and steering and increase risk of losing control.

ALWAYS:

- use proper riding techniques to avoid vehicle overturns on hills and rough terrain and in turns.
- avoid paved surfaces - pavement may seriously affect handling and control.

**LOCATE AND READ OWNER'S MANUAL.
FOLLOW ALL INSTRUCTIONS AND WARNINGS.**