



2026 OPERATOR'S MANUAL



Sasquatch XTX

Do not remove this manual from this vehicle.

Part #: 100-0730

Effective Date 7/2025 Rev. 0

NOTE

Read this manual **before** you operate your ARGO XTV. It contains safe operating instructions and warns the user about potential hazards that can result in personal injury.

Warnings are identified in the text by the following symbol:



WARNING

Warning text warns the user about potential hazards that can result in personal injury or death.

Cautions are identified in the text by the following symbol:



CAUTION

Caution text contains cautions that can prevent damage to the XTV.

This manual is based on the latest product information available at the time of printing. ARGO reserves the right to make changes at any time and without obligation.

Reproduction of any part of this publication is prohibited without prior written permission.

© 2025 ARGO



WARNING

WARNING: Breathing diesel engine exhaust exposes you to chemicals known to the State of California to cause cancer and birth defects or other reproductive harm.

- Always start and operate the engine in a well-ventilated area.
- If in an enclosed area, vent the exhaust to the outside.
- Do not modify or tamper with the exhaust system.
- Do not idle the engine except as necessary.

For more information go to:

www.P65Warnings.ca.gov



WARNING

WARNING: This product can expose you to chemicals including lead, which is known to the State of California to cause cancer and birth defects or other reproductive harm.

For more information go to:

www.P65Warnings.ca.gov

Introduction

ARGO welcomes you to its growing family of new product owners. This Xtreme Terrain Vehicle (XTV) has been designed with care and built by skilled workers using quality materials.

Proper setup, maintenance and safe operating practices will help you get years of satisfactory use from this XTV.

Your safety and the safety of all ARGO users is of the greatest concern to us. You will find numerous safety statements in this manual. Please read and follow them carefully. Always be safety conscious when you operate your ARGO and remember it is a motorized vehicle.

Please take the time to develop your driving skills before attempting new challenges. Observe the recommendations outlined in this Operator's Manual and remember; some things are just impossible, even with an ARGO.

WELCOME TO THE WORLD WIDE ARGO FAMILY!



PREFACE

This manual describes the controls, operation and basic maintenance procedures for the ARGO Sasquatch Xtreme Terrain Vehicle (XTV) from date of printing. Please take the time to read this manual carefully, for your safety and that of others. Keep this Operator's Manual with the vehicle at all times. By following these instructions, you will ensure extended, trouble free operation of your XTV.

FAILURE TO FOLLOW THE WARNINGS CONTAINED IN THIS MANUAL CAN LEAD TO SERIOUS INJURY OR DEATH.

For maintenance and adjustment of the engine, refer to the manufacturer's operation and maintenance manual included in your XTV's information package.

Before you drive your ARGO XTV, make sure you understand how to use all controls. Learn how to drive your XTV in an open level area, away from buildings, trees and other obstacles, until you are completely familiar with its operating characteristics. Drive very slowly until your driving skills improve, and drive with caution and consideration at all times. Take special care during this period. ALWAYS RESPECT OUR ENVIRONMENT.

- Use common sense at all times when driving your XTV.

IMPORTANT

Operate this XTV with safety constantly in mind. Off-road vehicles face unpredictable and often hazardous terrain conditions. It is ultimately the operator's responsibility to handle the XTV safely within its limitations and to decide when and where to travel.

FOR MORE INFORMATION ON OUR FULL PRODUCT OFFERING, VISIT OUR WEBSITE ARGOXTV.com

- For a detailed description of warranty coverage for your XTV, refer to the Warranty section found in this Owner's Manual or visit our website.
- For a detailed description of the Emissions Warranty for your XTV, refer to the Emissions Warranty section of this Owner's Manual or visit our website.

ARGO WANTS YOU TO BE SATISFIED WITH YOUR NEW XTV. IF YOU DO NOT UNDERSTAND ANY PART OF THIS MANUAL OR ARE NOT SATISFIED WITH THE SERVICE RECEIVED, PLEASE TAKE THE FOLLOWING ACTIONS:

Discuss the matter with your dealership service manager. Make sure they are aware of any concerns you may have so they can assist you.

REPLACEMENT PARTS, ACCESSORIES and SERVICE

- Most replacement parts and accessories are typically available from your dealer. For immediate availability and convenience, it is recommended items be ordered from an authorized dealer. Take this manual and all supplements to the dealer when ordering parts in person.
- Unapproved installation of parts or accessories can create a substantial safety hazard and increase the risk of personal injury.
- Use authorized parts only.

TABLE OF CONTENTS

SECTION I - Safety

Safety	1
Consumer Responsibilities	5
Safety Label Locations	6
Warnings	8

SECTION 2 - Specifications and Technical Characteristics

Engine	14
Specifications	14

SECTION 3 - Technical Description

XTV Structure	16
XTV General View	16
XTV Dimensions	17
Location of Controls and Devices	18
Fuse Panels	
Main Power Fuse Panel	26
Chassis Power Fuse Panel	26
HVAC Power Fuse Panel	26
Engine Relay Block	27
Cab Power Fuse Panel	27
Fan Power Fuse Block	27
Steering Power Fuse Block	28
Battery Fuse	28
Display Features and Operation	
Soft Keys and Touch Screen	29
Home Screen	29
Compass	29
Vehicle Speed	30
Engine Oil Pressure	30
Engine Coolant Temperature	30
Engine RPM	30
Gear Position	31
Fuel Level Indicator	31
Tilt and Incline Gauges	32
Tire Pressure	32
Tire Inflation System and Tire Pressure Selection	33
Road	33
Water	33
Trail	33
Mud	33
Snow	33
Up / Down Arrows	34
Screen Settings	34
Set Time / Date	35
Soft Key Backlight Color	35
Display Brightness	35

Vehicle Info Screen.....	35
Manual Screen	37
Camera Screen	38
Diagnostic Screen	38
Engine ECU Faults.....	39
Steering Control Faults.....	40
Cooling Fan Faults	40
Input Screen	41
Output Screen	41
Night Screen.....	42
Zero Turn	43
Door Switches	43

SECTION 4 - XTV Operation

Pre Operation Check and After Operation Maintenance	44
Entrance to the XTV Cab from Front.....	45
Entrance to the XTV Cab from Side	45
Exit the XTV Cab	45
Emergency Exit from the Cab.....	46
Front Seat Adjustments	46
General Driving.....	47
Braking	47
Shifting.....	47
Fueling the XTV	48
Wheel Canisters	48
Engine Start.....	49
Cold Weather Starting	50
Engine Stop.....	50
Reverse Engine Operation	51
Tire Inspection During Operation.....	51
Tire Operation Conditions.....	51
General Cases of XTV Operation.....	52
New XTV Break-In Procedures	52
Operation in Remote Areas	52
Driving on Sandy Areas, Loose Soil and Snow	53
Driving Uphill and Downhill.....	53
Driving on Waterlogged Terrain	54
Passing Water Barriers.....	54
Passing Water to Ice Barriers.....	54

SECTION 5 - Technical Maintenance

Types and Frequency.....	56
Measurements for Adjustments and Control	59
Filling Volumes	60
Engine Oil Level Check	61
Engine Oil Change	62
Checking / Changing Transmission Oil.....	64
CVT Belt and Clutch Removal / Cleaning.....	66
Chain Case Fluid Check.....	67
Chain Case Fluid Drain / Fill.....	68

Fuel Filter Maintenance	69
Primary Fuel Filter	69
Secondary Fuel Filter	70
Bleeding Fuel System.....	70
Coolant Check / Fill	71
Air Filter Maintenance.....	72
Brake Fluid Maintenance.....	73
Windshield Washer Fluid Maintenance	73
Wheels and Tires - General Provisions	74
Dismounting Wheel Assembly	75
Mounting Wheel Assembly	75
Tire Repair	75
Tire Maintenance.....	76
Wheel Lugnut Maintenance.....	76
XTV Towing	76
Securing the XTV for Transportation	76
XTV Storage.....	77

SECTION 6 - Fault Codes

Steering Controller DTCs	78
Fan Controller DTCs.....	90
Engine DTCs	94

SECTION 7 - Ratings 107

SECTION 8 - Warranty

Limited Warranty	108
EPA Emission Warranty.....	110

Customer Information/Customer Checklist.....	112
--	-----

Pre-Ride Inspection.....	113
--------------------------	-----

SECTION 1

Safety

This is a high performance, off-road vehicle and can be hazardous to operate.

This XTV handles differently from other vehicles, including cars and motorcycles. A collision or rollover can occur quickly, even during what you think are routine operating procedures such as turning, driving on hills, and going over obstacles, if you fail to take necessary precautions.

AGE OF OPERATOR

Operators must be 16 or older with a valid driver's license.

ASSUMPTION OF RISK

The owner or operator assumes all the risks related to or arising from the operation of this XTV.

ATTENTION:

ALWAYS PERFORM A PRE-RIDE INSPECTION OF THE XTV USING THE CHECKLIST PROVIDED ON THE INSIDE BACK COVER OF THIS MANUAL.

Your XTV has been designed with many built-in safety features. However, no one should operate this XTV before carefully reading this Operator's Manual. Pay special attention to the **CAUTIONS** and **WARNINGS** contained in this manual as well as all instructions noted on the safety labels/decals.

- Forming good habits and developing driving skills is an ongoing process. Even if you are an experienced driver, take time to become familiar with the controls, handling characteristics, capabilities, size and weight of your XTV.
- Before operating this XTV, the owner and each operator must understand that this XTV is designed to be an off-road vehicle and has not been manufactured to meet specifications for use on public roads, streets, highways and thoroughfares.
- The owner, operator(s) and passenger(s) must read and understand all the instructions for proper assembly and safe operation, as well as the instructions concerning the engine and all other portions of the XTV, as described and illustrated in this manual.
- Be sure to follow the recommended maintenance schedule and service your XTV accordingly. Preventative maintenance is extremely important to the safe operation and longevity of your XTV.
- Inexperienced and first-time drivers are urged to seek instruction from a dealer or qualified instructor before and during the initial use of this XTV. It is also recommended to practice in a large open area to become familiar with the XTV's operation.
- The driver must be trained and familiarized with the operation and maintenance manual before use. An untrained driver operating this XTV can result in injury or death.
- **NEVER use handheld electronic devices while driving this XTV. Driving while distracted can result in loss of vehicle control, accident and injury.**
- Do not operate a XTV with damaged or defective parts. A damaged XTV should be evaluated, inspected and repaired by an authorized ARGO service center, and defective parts should be replaced before putting the XTV back into service.



WARNING

Indicates a potential hazard that could result in a serious injury or death.

Safety

TO AVOID SERIOUS INJURY OR DEATH:

- Never allow operation of this XTV if a person is intoxicated by alcohol or drugs.
- Operate this XTV from the driver's seat only.
- Always use the seat belt and fasten it securely.
- The operator must always use both hands to operate.
- Always position your feet on pedals, and hands on the steering wheel.
- Ensure passengers are seated in factory-designed and supplied seating with seat belts fastened before operating (except when operating in water).
- It is recommended the XTV is equipped with a fire extinguisher, first aid kit and tool kit (not supplied) during operation.
- Always keep all body parts in the XTV at all times during operation.
- Do not exit a moving vehicle, as serious injury or death could occur.
- Never get out of the cab or the passenger compartment when in motion.
- Always engage the parking brake when XTV is parked or prior to exiting the XTV.
- Never attempt to modify the XTV structure.
- NEVER start the engine without the operator properly seated, the restraint system properly adjusted and secured with the parking brake engaged and the XTV in neutral.
- NEVER start the engine without checking to see that the throttle control is in the idle position.
- ALWAYS use extreme caution when starting the engine.
- Do not leave this XTV unattended with the engine running.
- Safety decals must be replaced if they become unreadable or detached from the XTV.
- **NEVER operate the XTV with engine shields or guards removed.**
- Always inspect all floor panels, parts of covers and guards. They must always be secured to prevent damage by moving parts.
- Do not touch engine, exhaust pipe, shields or muffler. Surfaces on or around the engine can be extremely hot.
- Always go slowly and use extra caution when operating on unfamiliar terrain.
- Never try to move through/over an area you are not sure you will overcome. Some terrain and slopes are impossible to cross.
- Always be alert to changing terrain conditions when operating this vehicle.
- Always follow proper procedures for turning as described in this manual. Practice turning at slower speeds before attempting to turn at faster speeds. Do not attempt to turn at excessive speed.
- Always follow proper procedures for climbing hills. Check the terrain carefully before you start up any hill.
- Never operate on hills too steep for your abilities. Practice on smaller hills before attempting larger hills.
- Do not operate XTV on 35° slopes or steeper. Vehicle may overturn or damage to the engine due to oil starvation will occur.
- Always follow proper procedures when you attempt to climb or descend a hill. Never turn on a hill. Drive straight up or down inclines and not across them. If you must cross the side of a hill, drive slowly and stop or turn downhill if you feel the vehicle may overturn.
- Always follow proper procedures for operating on hills as described in this manual. Check the terrain carefully before you start down any hill. Never go down a hill at a high rate of speed. Go straight down the hill where possible.



WARNING

Indicates a potential hazard that could result in a serious injury or death.

Safety

- Never go over the top of any hill at high speed.
- Always follow proper procedures when operating over obstacles.
- Always check for obstacles before operating in a new area.
- Always be sure there are no obstacles or people behind you when you operate in reverse. When it is safe to proceed in reverse, go slowly. Avoid turning at sharp angles in reverse.
- Always follow the safety precautions and procedures described in this manual before moving through water.
- Always use caution when skidding or sliding. On slippery surfaces, such as ice, go slowly and be very cautious in order to reduce the chance of skidding or sliding out of control.
- Always use the size and type tires specified in this manual. Always maintain proper tire pressure as described in this manual.
- Never install or use unapproved accessories on this vehicle.
- Never exceed the stated load capacity for this vehicle. Cargo should be properly distributed and securely attached.
- The front bumper and brush guard are not designed as push bars. Do not attempt to push other vehicles or implements, or damage may result.
- Do not attach a trailer or implement to the hitch that will exceed the specified tongue/towing capacity, or loss of control may result.
- Follow all towing instructions in this manual when transporting the XTV behind another vehicle.
- Do not use this XTV as an anchor device.
- Beware: Tow ropes, cables and chains can break when pulling another vehicle or object, causing serious injury or death to anyone in line with the whipping action created when they break. Never jerk when pulling; always ease into a pull gently. Always stay clear of the tow line.
- Assembly, maintenance and/or repair of this XTV should only be performed by authorized ARGO dealers or authorized engine centers (for engine repairs) to avoid unsafe conditions or modifications.
- NEVER adjust, repair or clean the XTV while in motion or with the engine running.
- Prevailing torque-type lock nuts must be replaced with new ones after the old lock nuts have been removed. (Refer to Parts Manual for part number).
- NEVER fill the fuel tank while the engine is running or hot.
- Always use an original fuel cap or OEM (Original Equipment Manufacturer) replacement.
- NEVER fill the fuel tank while the XTV is inside a building without adequate ventilation.
- Exhaust fumes are toxic.
NEVER operate this XTV indoors or in an enclosed area without adequate ventilation.
- DO NOT disconnect the negative battery cable with the engine running. This may damage the Electronic Control Unit (ECU).
- Battery fumes are explosive. A spark will ignite battery fumes. Wear a face shield when charging or jumping a battery. Follow all battery safety rules outlined in this manual.



WARNING

Indicates a potential hazard that could result in a serious injury or death.

Safety

- Engine must be allowed to cool before storage in any enclosure.
- XTV must be stored where diesel fuel fumes will not reach an open flame, spark or other source of ignition.
- For long-term storage, the fuel tank should be filled to capacity with diesel.



WARNING

Indicates a potential hazard that could result in a serious injury or death.

Consumer Responsibility

- Prior to each use, the operator shall perform the pre-operation checks specified by the manufacturer and further verify the following:
 - Smooth throttle operation and positive return of the throttle pedal to a closed throttle position when released.
 - Steering wheel rotates freely.
 - Engine stop switch or key switch is properly functioning.
 - All guards, covers and shields originally supplied by the manufacturer are in proper place and in serviceable condition.
 - Engine idle speed is below the point of clutch engagement.
 - Fuel tank is in good condition.
 - Proper fuel cap is fastened securely.
 - Braking system is functioning properly.
 - All safety labels are in place, legible and understood.
 - Tires are in good condition and have sufficient tread remaining.
 - All fasteners are in place and tightened securely.
- XTV engine shall not be started unless the operator is seated and restrained in the proper position for XTV operation and the parking brake is fully engaged.
- XTV operators and passengers must adhere to all manufacturer's recommendations and instructions.
- XTV operators and passengers must comply with all laws and ordinances relating to the operation of this vehicle.
- XTV components must be maintained and repaired in accordance with the manufacturer's specifications, and the operator should utilize only the manufacturer's authorized replacement parts, with installation performed by authorized dealers.
- Strictly following maintenance and operation rules is your best protection against accident and injury. Please read this Section thoroughly and understand its requirements before operating.
- The XTV is equipped with an internal combustion engine which produces heat and exhaust gases. Any exhaust gases can cause sickness or death, therefore, always stop the engine before you start daily or scheduled maintenance, before refueling, greasing, repairing or cleaning.
- Do not open the coolant expansion tank plug when engine is running or when engine is hot. Allow engine to cool before opening. Otherwise, hot coolant can spill over from the tank.
- Fully relieve pressure in the fuel system, lubrication and cooling systems before removing or disconnecting any pipes, fittings or components connected to them.
- Be conscious about the environmental and ecological protection. Before draining any fluids, determine the correct disposal method. Follow environmental regulations during disposal of motor oil, fuel, coolant, hydraulic fluid, filters and batteries.
- Ensure front door, side doors and windows are in the closed and latched position.



WARNING

When driving this XTV, always remember safety. Accidents often occur on unknown and dangerous areas. The driver is fully responsible for passengers, cargo and overall safety, as well as for route selection.

LABEL LOCATIONS

IT IS VERY IMPORTANT TO READ, UNDERSTAND AND FOLLOW ALL INSTRUCTIONS, CAUTIONS AND WARNINGS LOCATED ON THE DECALS ON YOUR XTV

The following section has been prepared to instruct you in the safe and responsible operation of your XTV. Read and abide by all safety alert information about this XTV. If you do not understand any part of this section, contact your local dealer for additional information and clarification. As the operator of this XTV, you are in complete control. Only you can prevent an accident from happening.

FRONT VIEW



REAR VIEW



WARNING

Indicates a potential hazard that could result in a serious injury or death.

Label Locations

1



5

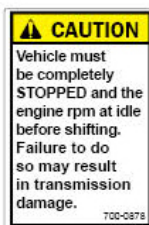

2



6



7



8



3



9

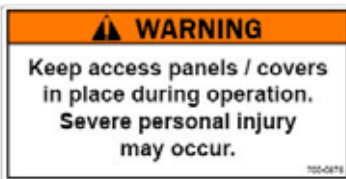

4

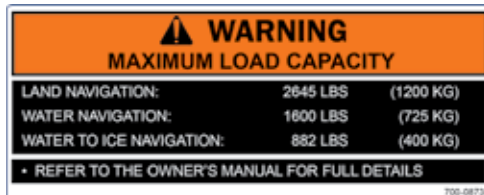

10



WARNING

Indicates a potential hazard that could result in a serious injury or death.

Warnings

POTENTIAL HAZARD

Operating this vehicle without proper instruction.

WHAT CAN HAPPEN

The risk of an accident is greatly increased if the operator does not know how to operate this vehicle properly in different situations and on different types of terrain.

HOW TO AVOID THE HAZARD

All operators of this vehicle must read and understand this Operator's Manual and all warning and instruction labels prior to operating this vehicle.

POTENTIAL HAZARD

Allowing anyone under age 16 to operate this vehicle.

WHAT CAN HAPPEN

Use of this vehicle by children can lead to serious injury or death of the child. Children under the age of 16 may not have the skills, abilities, or judgment needed to operate this vehicle safely and may be involved in a serious accident.

HOW TO AVOID THE HAZARD

Operators 16 years of age or older with a valid driver's license and proper training should operate this vehicle.

POTENTIAL HAZARD

Operating this vehicle on public streets, roads, or highways.

WHAT CAN HAPPEN

You can collide with another vehicle.

HOW TO AVOID THE HAZARD

Never operate this vehicle on any public street, road, or highway. In many states it is illegal to operate a vehicle of this type on public streets, roads, or highways. Always check state and local laws and regulations.

POTENTIAL HAZARD

Allowing passengers to sit in cargo area.

WHAT CAN HAPPEN

Serious injury or death. This vehicle is designed to carry passengers in the designed and supplied seating only. Passengers in the cargo area can be thrown around or from the XTV during operation.

HOW TO AVOID THE HAZARD

Do not permit passengers to ride in the cargo area.

POTENTIAL HAZARD

Operating this XTV after or while consuming alcohol or drugs.

WHAT CAN HAPPEN

- Can seriously affect your judgment.
- Can cause you to be slow to react.
- Can affect your balance and perception.
- Can result in an accident.

HOW TO AVOID THE HAZARD

Never consume alcohol or drugs before or while operating this XTV.



WARNING

Indicates a potential hazard that could result in a serious injury or death.

Warnings

POTENTIAL HAZARD

Operating or riding in the XTV without wearing a properly secured seat belt.

WHAT CAN HAPPEN

Serious injury or death. Occupants can strike objects in the passenger compartment, fall out of the XTV during operation, or be crushed or otherwise injured in the event of an accident.

HOW TO AVOID THE HAZARD

ALWAYS WEAR YOUR SEATBELT and require others to wear their seat belts.

POTENTIAL HAZARD

Failing to keep all body parts inside the compartment during operation.

WHAT CAN HAPPEN

Serious injury or death. Occupants can strike objects outside of the XTV or be crushed or otherwise injured in the event of an accident.

HOW TO AVOID THE HAZARD

Do not place your head, arms, hands, legs, or feet outside of the XTV during operation. Stay seated with the seat belt fastened and properly secured.

POTENTIAL HAZARD

Operating this XTV at excessive speeds.

WHAT CAN HAPPEN

Increases the chance of losing control of the XTV, which can result in an accident.

HOW TO AVOID THE HAZARD

Always operate at a speed that is proper for the terrain, visibility, load and operating conditions.

POTENTIAL HAZARD

Attempting stunts.

WHAT CAN HAPPEN

Increases the chance of losing control of the XTV, which can result in an accident.

HOW TO AVOID THE HAZARD

Never attempt stunts. Don't try to show off.

POTENTIAL HAZARD

Failure to inspect the XTV before operation.

Failure to properly maintain the XTV.

WHAT CAN HAPPEN

Increases the possibility of an accident or equipment damage.

HOW TO AVOID THE HAZARD

Always inspect the XTV every time you use it following the Pre-Operation Inspection. Ensure it is in safe operating condition.

Always follow the inspection and maintenance procedures and schedules described in this Operator's Manual.



WARNING

Indicates a potential hazard that could result in a serious injury or death.

Warnings

POTENTIAL HAZARD

Failure to use caution when operating this XTV on unfamiliar terrain.

WHAT CAN HAPPEN

You may encounter hidden rocks, bumps, or holes without enough time to react, which could result in the vehicle going out of control.

HOW TO AVOID THE HAZARD

Use caution when operating on unfamiliar terrain. Always be alert to changing terrain conditions.

POTENTIAL HAZARD

Failure to use caution when operating this XTV on rough, slippery, or loose terrain.

WHAT CAN HAPPEN

You may lose traction or control, which could result in an accident.

HOW TO AVOID THE HAZARD

Do not operate this XTV on rough, slippery, or loose terrain until you have learned and practiced the skills necessary to control this XTV on such terrain.

POTENTIAL HAZARD

Failure to use caution in turns; turning too sharp or aggressive.

WHAT CAN HAPPEN

You may lose control, which could result in an accident.

HOW TO AVOID THE HAZARD

Always follow proper procedure for turning. Practice turning at slower speeds before attempting to turn at faster speeds. Do not attempt to turn at excessive speeds or too sharp for the conditions and for your experience level.

POTENTIAL HAZARD

Operating on steep hills.

WHAT CAN HAPPEN

This XTV can overturn more easily on steep hills than on level surfaces.

HOW TO AVOID THE HAZARD

Never operate this XTV on hills too steep for the vehicle or for your abilities. Practice on smaller hills before attempting larger hills.

POTENTIAL HAZARD

Going down a hill improperly.

WHAT CAN HAPPEN

You may lose control, which could result in an accident.

HOW TO AVOID THE HAZARD

Always follow proper procedures for going down hills.
Always check the terrain carefully before you start down any hill.
Never go down a hill at high speeds.
Avoid going down a hill at an angle that would cause the vehicle to lean sharply to one side. Go straight down the hill where possible.



WARNING

Indicates a potential hazard that could result in a serious injury or death.

Warnings

POTENTIAL HAZARD

Climbing hills improperly.

WHAT CAN HAPPEN

You may lose control, which could result in an accident.

HOW TO AVOID THE HAZARD

Always follow proper procedures for climbing hills.

Always check the terrain carefully before you start up any hill.

Never climb hills with slippery or loose surfaces.

Never go over the top of any hill at high speeds. An obstacle, sharp drop, or another vehicle or person may be on the other side.

Never Operate Up or Down Hills Steeper than 35°

Do not operate XTV on 35° slopes or steeper. Vehicle may overturn or damage to the engine due to oil starvation will occur.

POTENTIAL HAZARD

Crossing hills or turning on hills.

WHAT CAN HAPPEN

You may lose control, which could result in an accident.

HOW TO AVOID THE HAZARD

Never attempt to turn the XTV around on any hill. If you must cross the side of a hill, use caution and stop or turn downhill if you feel the XTV may tip.

POTENTIAL HAZARD

Stalling, rolling backwards while climbing a hill.

WHAT CAN HAPPEN

You may lose control, which could result in an accident.

HOW TO AVOID THE HAZARD

Use proper gear and maintain steady speed when climbing a hill.

If you lose all forward momentum:

Apply the brakes. Place the transmission in neutral and engage the parking brake after you are stopped.

If you begin rolling backwards:

Apply the brakes while rolling backwards. When fully stopped, with brakes applied, shift the transmission into neutral and engage the parking brake.



WARNING

Indicates a potential hazard that could result in a serious injury or death.

Warnings

POTENTIAL HAZARD

Improperly operating in reverse.

WHAT CAN HAPPEN

You may contact an obstacle or person behind you, resulting in serious injury or death.

HOW TO AVOID THE HAZARD

Before you engage the reverse gear, make sure there are no obstacles or people behind you. When it is safe to proceed, go slow.

POTENTIAL HAZARD

Improperly operating over obstacles.

WHAT CAN HAPPEN

You may lose control, which could result in an accident.

HOW TO AVOID THE HAZARD

Before operating on unfamiliar terrain, check for obstacles.
Never attempt to operate over large obstacles, such as large rocks or fallen trees. When going over obstacles, always follow proper procedures.

POTENTIAL HAZARD

Skidding or sliding.

WHAT CAN HAPPEN

You may lose control, which could result in an accident.

HOW TO AVOID THE HAZARD

Learn to safely control skidding or sliding by practicing at slow speeds on level, smooth terrain.
On extremely slippery surfaces, such as ice or snow, go slow and use caution.

POTENTIAL HAZARD

Operating the XTV with improper tires or improper tire pressure.

WHAT CAN HAPPEN

You may lose control, which could result in an accident.

HOW TO AVOID THE HAZARD

Always use the size and type of tires specified in this Operator's Manual.
Always maintain proper tire pressure for the terrain you are operating on.



WARNING

Indicates a potential hazard that could result in a serious injury or death.

Warnings

POTENTIAL HAZARD

Overloading the XTV.

WHAT CAN HAPPEN

You may lose control, which could result in an accident.

HOW TO AVOID THE HAZARD

Never exceed the stated load capacity for this XTV.

Cargo should be properly distributed and securely attached.

Reduce speed when carrying cargo. Allow greater distance for braking.

POTENTIAL HAZARD

Operating the XTV in fast flowing water.

WHAT CAN HAPPEN

Vehicle may float, causing loss of traction which could result in reduced maneuverability.

HOW TO AVOID THE HAZARD

Use extreme caution when operating this XTV in water.

Remember that wet brakes may have reduced stopping capability.

Test the brakes after exiting the water. If necessary, apply the brakes several times to dry out the brake pads.

POTENTIAL HAZARD

Operating this XTV with improper modifications.

WHAT CAN HAPPEN

Improper installation and improper use of accessories or modification of the XTV may cause changes in operation which, in some situations, may lead to an accident.

HOW TO AVOID THE HAZARD

Never modify this XTV through improper installation or improper use of accessories.

All parts and accessories added to this XTV should be components designed for use on this XTV and should be installed and used according to instructions.



WARNING

Indicates a potential hazard that could result in a serious injury or death.

SECTION 2

Specifications and Technical Characteristics

Engine

The ARGO Sasquatch engine provides advanced performance in its class with the most demanding environmentally-conscious technologies. The diesel engine provides fuel efficiency with a low level of noise and vibration. The engines are adapted for work in any climate, which makes it possible to operate the XTV in most all conditions.

Model: Hyundai D18

High Pressure Common Rail Fuel Injection Full ECM



SPECIFICATIONS / TECHNICAL CHARACTERISTICS

Engine model	Hyundai D18
Fuel type	Diesel
Engine DOC (Diesel Oxidation Catalyst)	DOC only
Engine displacement	Turbo Charged 1.8 L (61 cu in)
Cylinder count	3
Engine Oil	15W40 (API CK-4 / ACEA E6) - 6.6 qt (6.3 L)
Alternator performance	12V - 140 A
Battery	12V - H6 850 CCA (recommended minimum)
Length (Overall)	157 in (4002 mm)
Width (Overall)	101 in (2565 mm)
Height (Overall)	113 in (2870 mm)
Ground clearance	26 in (680 mm)
Wheelbase	86 in (2184 mm)
Dry Weight	5390 lbs (2445 kg)
Gross Vehicle Weight Rating (GVWR)	8310 lbs (3769 kg)
Load capacity (includes tongue weight)	up to 2645 lbs (1200 kg)

SPECIFICATIONS / TECHNICAL CHARACTERISTICS

Maximum Towing capacity	5180 lbs (2350 kg)
Maximum Tongue Weight	330 lbs (150 kg)
Brakes	Hydraulic disc brake
Parking brake system	Mechanical handbrake
Steering	Steer by wire
Tire size	71 x 23 - 25 in (1800 x 600 - 635)
Type of tires	XT 328 Tubeless, extra-low pressure
Suspension	Adjustable pneumatic circulating tires
Tire Pressure	1.0 - 3.5 psi (51 - 180 mm Hg)
Incline / Climb / Descend	35 degrees
Side hill	30 degrees
Fuel tank volume	26.5 gal (100 L) - 185 lb (84 kg)
Transmission	Overdrive / Drive / Reverse / Neutral
Final drive	Enclosed oil bath
Minimum crawl speed (in the low gear)	1.2 Mph (2 km/h)
Water speed	4 Mph (6 km/h)
Capacity of additional wheel canisters	4 x 9 gal (4 x 34 L) - (4 x 63 lb (4 x 29 kg)

SPECIFICATIONS / LOADING CAPACITIES



WARNING

DO NOT OVERLOAD THE VEHICLE. SERIOUS INJURY OR DEATH MAY RESULT.

WARNING

MAXIMUM LOAD CAPACITY

LAND NAVIGATION:	2645 LBS	(1200 KG)
WATER NAVIGATION:	1600 LBS	(725 KG)
WATER TO ICE NAVIGATION:	882 LBS	(400 KG)

• REFER TO THE OWNER'S MANUAL FOR FULL DETAILS

700-0673



CAUTION

Maximum load capacities would include all occupants, cargo, wheel canister contents, accessories, or any additional equipment on board the vehicle.

NOTE: Refer to SECTION 4 - XTV OPERATION for more information.

SECTION 3

Technical Description

XTV Structure

All models of ARGO vehicles generally consist of the following main components: power train, transmission, control system, electrical equipment and bodywork. The cab includes the driver's and passenger's seat, seat belts, inner lining with sound and heat-insulating materials, the front windshield and side (all open) glass, dashboard, front and door serving as a support during entering and exiting the cab, foot and hand controls.

XTV - General View

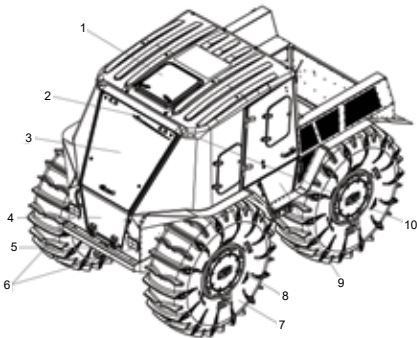

1. Emergency hatch
2. Windshield wiper
3. Windshield
4. Front entry/exit door
5. Front bumper
6. Running lights
7. Wheels
8. Wheel canister
9. Side entry/exit door
10. Flashing beacons front

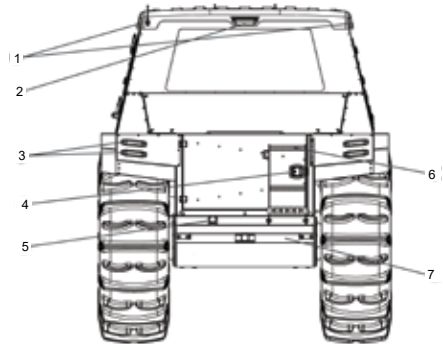

1. Flashing beacons rear
2. Rear view camera / cargo box light
3. Tailights
4. Tailgate
5. Fuel fill (Diesel)
6. Ladder
7. Rear bumper

XTV - Dimension

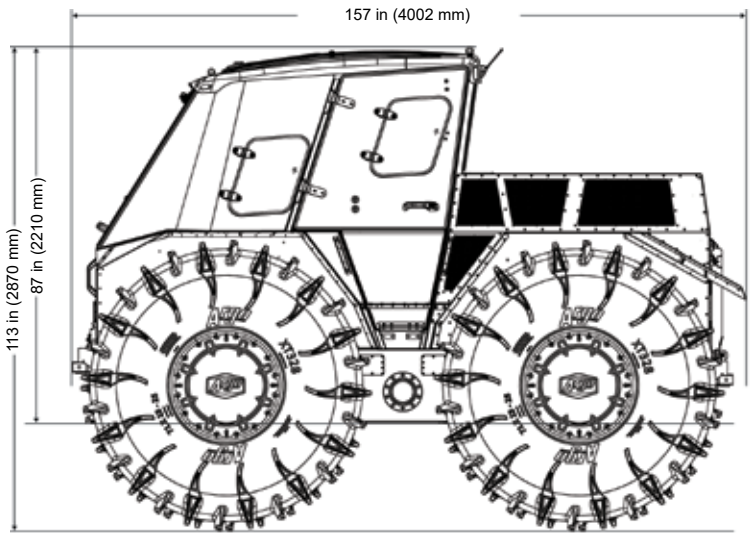
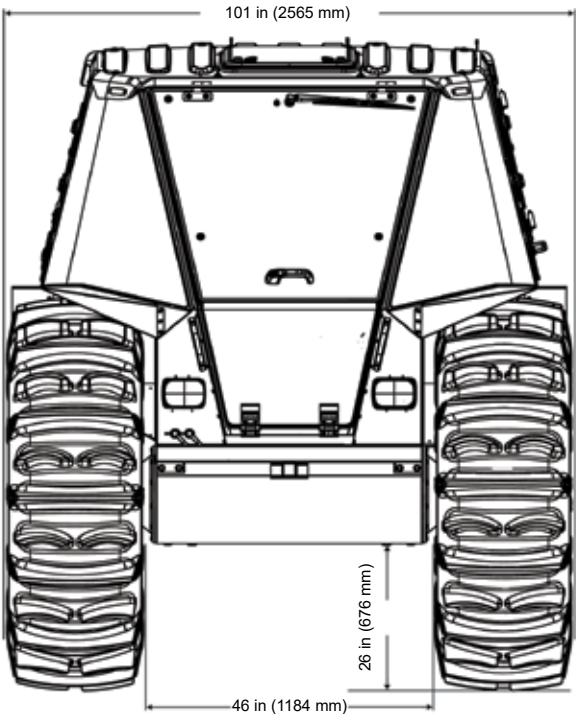

Location of Controls and Cab Devices

1	Display	See Display section.
2	Ignition Switch	Switch has four positions: - Accy (rotate to left) - OFF - ON - Ignition, fuel pump, engine glow plugs and system power - Momentary starter switch
3	Multi-Function Switch	Left and Right Turn Signals Running / High Beam / Low Beam Horn
4	Shift Lever	Drive / Neutral / Over-Drive / Reverse
5	Tilt Steering Lever	Release to adjust tilt steering.
6	USB (Type A) / USB (Type C)	Used to charge / operate accessory devices.
7	Bilge Pump Switch	Switch has three positions: Auto / OFF / Manual
8	HVAC Control Panel	Fan Control Recirculation A/C Temperature Control
9	Roof Hatch Release Levers	Used to release roof hatch.
10	Windshield Wiper / Washer	Three position switch: Washer - OFF - ON Momentary (switch must be depressed to dispense washer fluid)
11	Hazard Switch	Activates flashing lights on the exterior of the vehicle.
12	Strobe Light Switch	Activates strobe lights on the roof corners of the vehicle.
13	Cargo Light Switch	Activates rear cargo box light.
14	Interior Light Switch	Activates lights in the Cab area.
15-17	Spare	
18	Brake Pedal	
19	Accelerator Pedal	
20	Parking Brake Lever	
21	Seat Adjustment Levers	Used to adjust seats forward and backwards.
		Used to adjust seat backs.

Location of Controls and Cab Devices

22	Cab Air Filter Access	
23	Battery Disconnect Switches (12V / 54V)	<p>12V - Main power switch - three positions</p> <ul style="list-style-type: none"> - OFF - ON (BAT 1) (Normal Operation) - COMBINE BATTERIES (BAT1 / BAT2) <p>NOTE: COMBINE BATTERIES to be used if BAT1 does not have enough power to start the vehicle.</p> <p>54V - Two position switch to ground connection. Switch has a removable key when switch is turned to the "OFF" position.</p>
24	Front Door Release Lever	<p>Used to release front door to the open position.</p> <p>CAUTION: Front window must be in the OPEN position before lowering the front door.</p>
25	Front Window Release Lever	Used to release the front window into the OPEN position.
26	Rear Ladder	<p>Deploy the ladder to enter the rear cargo area.</p> <p>CAUTION: Ladder must be returned to the STOWED position before operation.</p>
27	Rear Cargo Bed Door Latch	
28	Fuel Fill (Diesel)	
29	Rear Receiver Hitch Location	Vehicle is prepped with front and rear receiver hitch locations.
30	Rear Box Tie Down Locations	Four "D" rings located in the corners of the rear cargo bed for anchor purposes.
31	HVAC Power Fuse Panel	See Fuse Panels Section.
32	Main Power Fuse Panel	See Fuse Panels Section.
33	Engine Relay Panel	See Fuse Panels Section.
34	Chassis Power Fuse Panel	See Fuse Panels Section.
35	Fan Power Fuse Block	See Fuse Panels Section.
36	Steering Power Fuse Block	See Fuse Panels Section.
37	Steering Relay	See Fuse Panels Section.
38	Cab Power Fuse Panel	See Fuse Panels Section.
39	Battery Fuse	See Fuse Panels Section.
40	Schrader Valve	Used to inflate tires if Inflation pump does not operate properly.

Location of Controls and Cab Devices

Before operating this vehicle, become familiar with all control locations and their purposes.

Cab

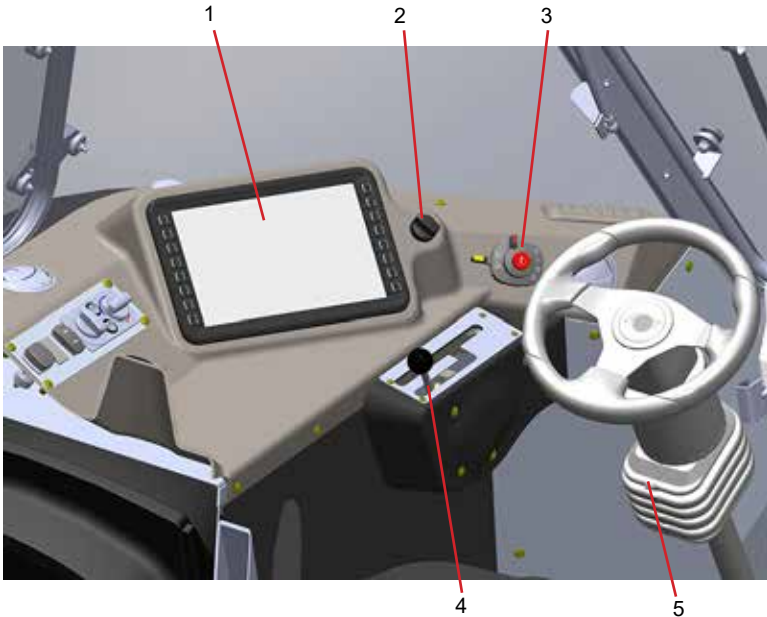

- 1. Display
- 2. Ignition Switch
- 3. Multi-Function Switch
- 4. Shift Lever
- 5. Tilt Steering Lever

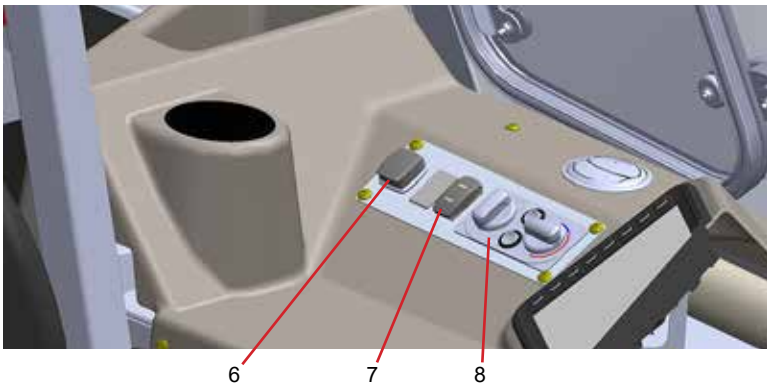

- 6. USB / USB-C
- 7. Bilge Pump Switch
- 8. HVAC Control Panel

Location of Controls and Cab Devices

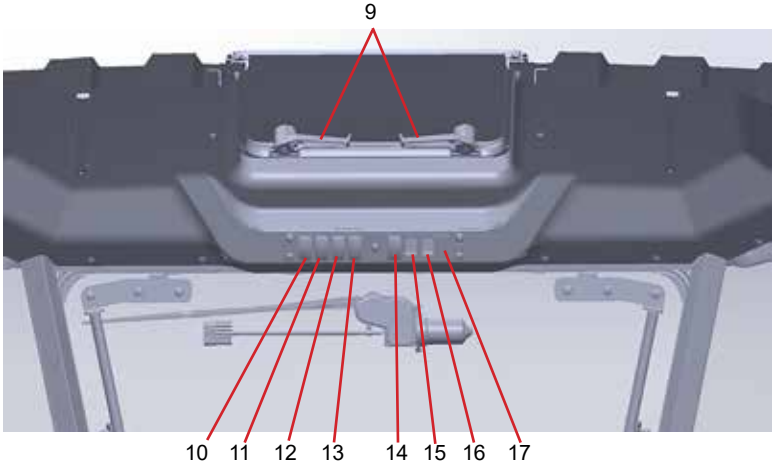

- 9. Roof Hatch Release Levers
- 10. Windshield Wiper / Washer Switch
- 11. Hazard Switch
- 12. Strobe Light Switch
- 13. Cargo Light Switch
- 14. Interior Light Switch
- 15. Spare
- 16. Spare
- 17. Spare

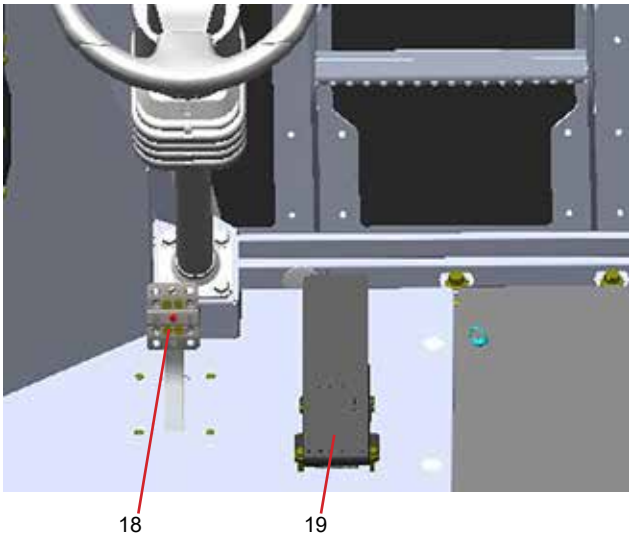

- 18. Brake Pedal
- 19. Accelerator Pedal

Location of Controls and Cab Devices

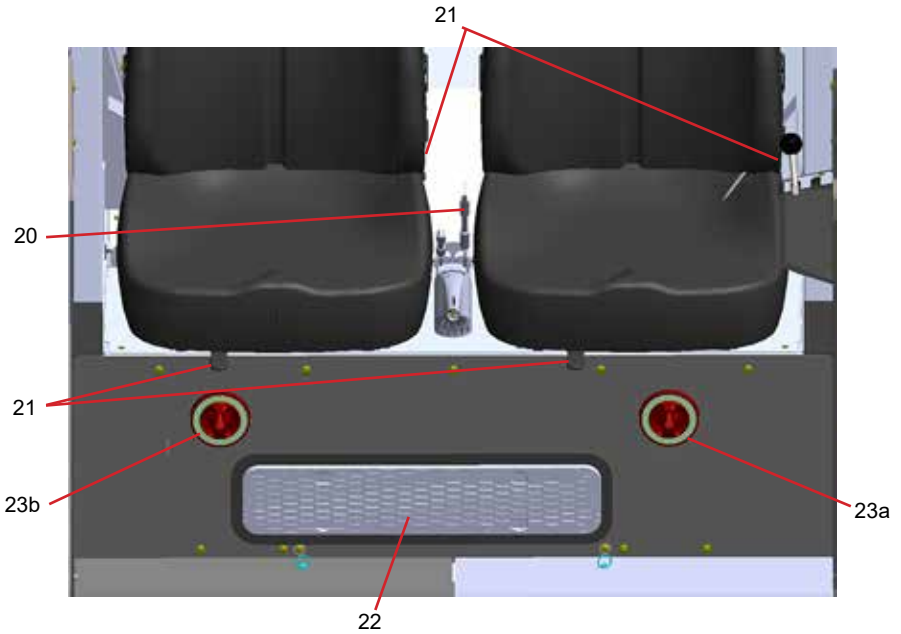

- 20. Parking Brake Lever
- 21. Seat Adjustment Levers
- 22. Cab Air Filter Access

- 23a. Battery Disconnect Switch (12V)
- 23b. Battery Disconnect Switch (54V)

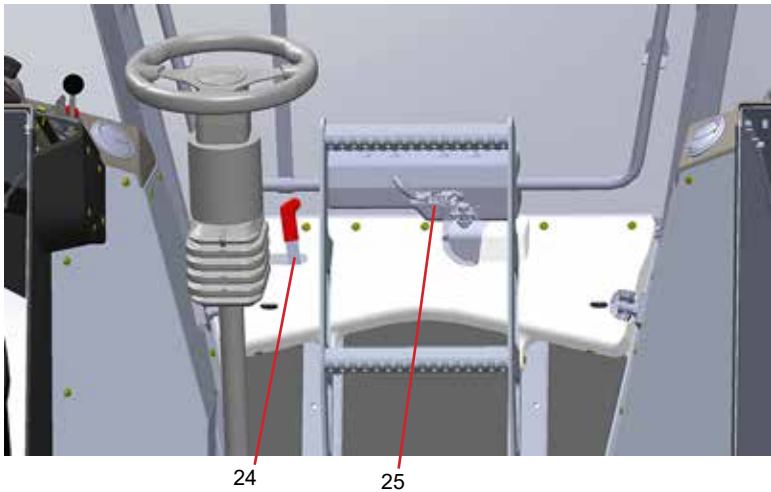

- 24. Front Door Release Lever
- 25. Front Window Release Lever

Location of Controls and Cab Devices

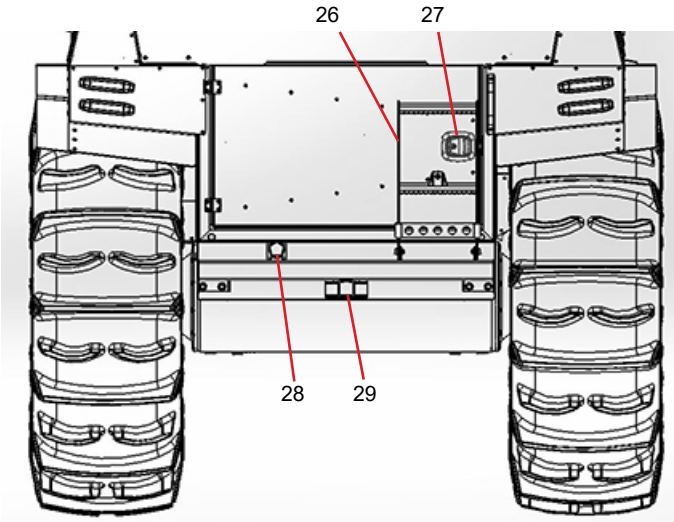

- 26. Rear Ladder
- 27. Rear Cargo Bed Door Latch

- 28. Fuel Fill
- 29. Rear Receiver Hitch Location

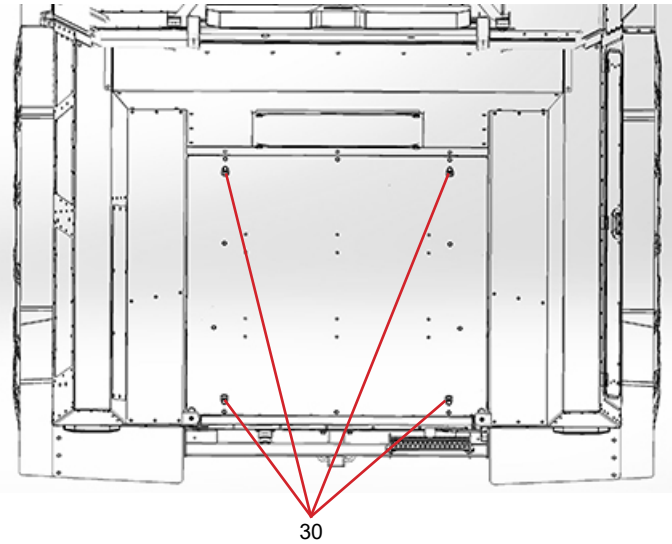

- 30. Rear Box Tie Down Locations

Location of Controls and Cab Devices

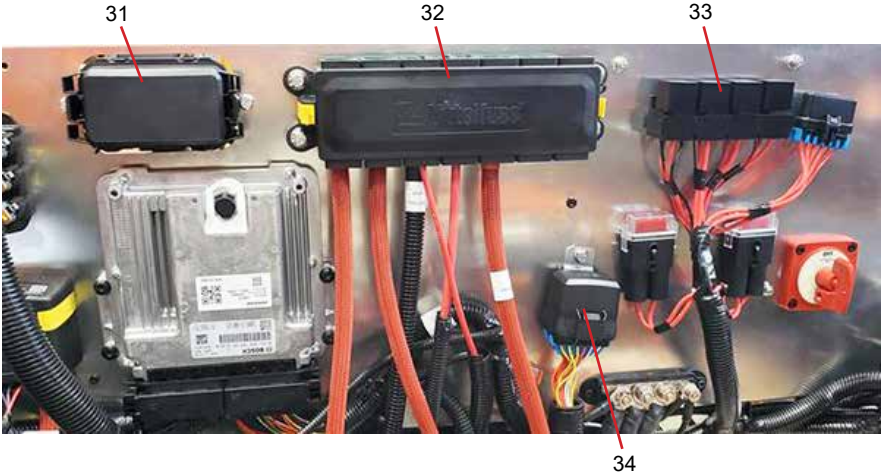

31. HVAC Power Fuse Panel
32. Main Power Fuse Panel

33. Engine Relay Panel
34. Chassis Power Fuse Panel



35. Fan Power Fuse Block
36. Steering Power Fuse Block
37. Steering Relay

Location of Controls and Cab Devices



38. Cab Power Fuse Panel



39. Battery Fuse

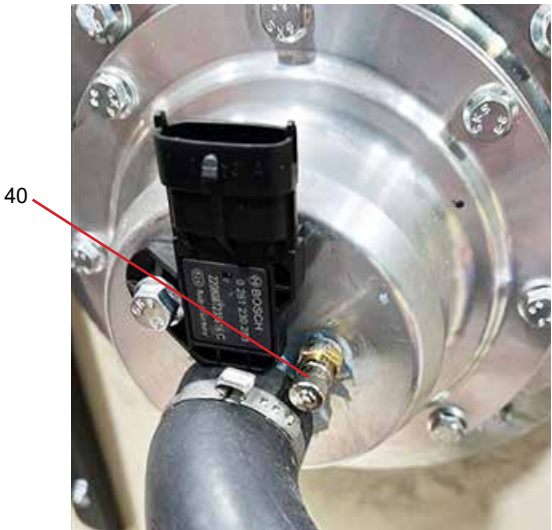

40. Schrader Valve

Fuse Panels

Main Power Fuse Panel

The Main Power Fuse Panel is located in the rear passenger area behind the closeout panel that is located below the driver and passenger seats.

SHUNT	CAB 100A	HVAC 80A	ENGINE 100A	TIRE 150A		WINCH 400A
-------	-------------	-------------	----------------	--------------	--	---------------

Chassis Power Fuse Panel

The Chassis Power Fuse Panel is located in the rear passenger area behind the closeout panel that is located below the driver and passenger seats.

ENGINE LIGHT 2A	CONTROLLER 15A	600-0394
PROG ENABLE 2A	CONTROLLER 15A	ACR 2A
PARK BRAKE 2A	CONTROLLER 3A	ACR 2A
STEERING 15A	CONTROLLER 2A	REVERSE LIGHTS 2A

HVAC Power Fuse Panel

The HVAC Power Fuse Panel is located in the rear passenger area behind the closeout panel that is located below the driver and passenger seats.

CONDENSER FAN 15A	PROPORTIONAL VALVE 2A	RECIRCULATION VALVE RELAY	RECIRCULATION VALVE RELAY	COMPRESSOR RELAY
CONDENSER FAN 15A	RECIRCULATION VALVE 2A			
COMPRESSOR 5A		IGNITION RELAY	CONDENSER FAN RELAY	CONDENSER FAN RELAY
CAB FAN 25A				
DASH CONTROL 5A	COMPRESSOR RELAY	CAB FAN LOW RELAY	CAB FAN MED RELAY	CAB FAN HIGH RELAY
A/C & RECIR 5A				

FUSE PANEL 600-0395

Fuse Panels

Engine Relay Block

The Engine Relay Block is located in the rear passenger area behind the closeout panel that is located below the driver and passenger seats.

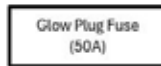
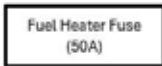

Cab Power Fuse Panel

The Cab Power Fuse Panel is located in the rear passenger area on the left hand side of the vehicle as you enter the door.

BILGE PUMP 10A	LIGHT BAR FR 15A	12V OUTLET 7.5A		WIPER AND WASHER RELAY	LIGHT BAR FRONT, SIDE AND REAR RELAY
DISPLAY-ACC 2A	DISPLAY-IGN 2A	AUX 5A			
IGN SWITCH 5A	CARGO/INT/VIS 7.5A	WASHER 5A	LIGHTS, HORN IGNITION RELAY	BILGE RELAY	RADIO, USB 12V OUTLET DISPLAY RELAY
TURN SIGNAL DICDE	TURNHAZARDS 5A	WIPER 20A			
THROTTLE STEERING 7.5A	HORN 7.5A	RADIO 15A	IGNITION RELAY	RIGHT TURN RELAY	LEFT TURN RELAY
H/LOW BEAM 10A	LIGHT BAR L/R 15A	USB 3A			

FUSE PANEL 600-0193

Fan Power Fuse Block

The Fan Power Fuse Block is located under the floor in the rear passenger area.



Fuse Panels

Steering Power Fuse Block

The Steering Power Fuse Block is located under the floor in the rear passenger area.

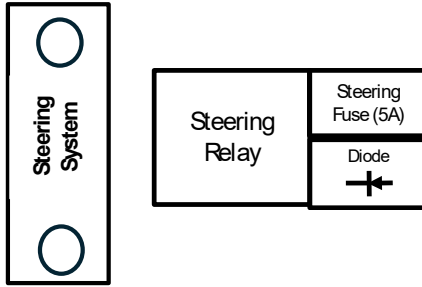

Battery Fuse

The Battery Fuse is located on top of each 12V positive battery post.

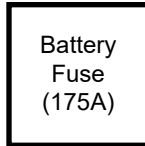

Display - Features and Operation

Soft Keys and Touch Screen

There are 16 Soft Keys to navigate through menus and to set tire pressure. Menu items within specific pages can be changed or selected using the touch screen of the display.

Home Screen

The Home screen is the default screen that will appear when the vehicle ignition is turned to the Run position. From this screen you can view Vehicle Speed, Oil Pressure, Compass Heading, Gear Position, Fuel Level, Tilt, Incline, Coolant Temperature, Engine RPM and Tire Pressure.



Display - Home Screen

Compass

The compass will display the direction of travel when the vehicle is moving and the GPS receiver has acquired satellite signal. When the GPS receiver has not acquired satellite signal, the GPS icon will be white. When the GPS receiver has acquired satellite signal, the GPS icon will be green.



Display - Home Screen

Vehicle Speed

The vehicle speed will be displayed on the left-hand main gauge in both analog needle gauge format and digital format.

Engine Oil Pressure

The engine oil pressure will be displayed on the left-hand main gauge in analog gauge format.



Engine Coolant Temperature

The engine coolant temperature will be displayed on the right-hand main gauge in analog gauge format

Engine RPM

The engine RPM will be displayed on the right-hand main gauge in both analog needle gauge format and digital format.



Display - Home Screen

Gear Position

The gear position indicator will show the transmissions current gear, Overdrive (OD), Drive (D), Neutral (N) or Reverse (R). If the parking brake is engaged when the transmission is placed in OD, D or R, an alarm will sound and a warning will appear on the display.



CAUTION

Driving the vehicle with the parking brake applied will cause damage.



Fuel Level Indicator

The fuel level indicator will display the current fuel level in the fuel tank.



Display - Home Screen

Tilt and Incline Gauges

The Tilt gauge will display the measured angle of the vehicle from side to side.

The Incline gauge will display the measured “UP” or “DOWN” incline the vehicle is being driven.

When the vehicle’s tilt or incline angle has reached the operating limit, the incline numbers and gauge background color will change to red to warn the operator.

To “ZERO” the tilt and incline sensors:

- Vehicle must be on level ground and the IMU warm-up message gone.
- Tap and hold the Sasquatch Tilt or Incline gauge you wish to zero until the offset is changed (approx. 5 seconds).



Tire Pressure

The Tire Pressure gauge will show target tire pressure and each individual measured tire pressure. If a tire pressure sensor circuit has an active error, the measured pressure number will be red in color.



Display - Tire Inflation System

Tire Inflation System and Tire Pressure Selection

From the Home screen, you can change the tire pressure settings based on terrain conditions for optimum vehicle performance and appropriate traction required.

Depress the desired “soft key” or display screen icon to adjust the terrain condition. The tire deflate system will operate with the engine in the “OFF” position.



WARNING

Never operate the vehicle with the tire pressure below 1.0 psi.



Tire Inflation System

The Tire Inflation System can only be activated when the engine is running and will be in the “last known” setting when the vehicle is started.

To adjust the tire pressure to the appropriate terrain, depress the desired softkey or display screen icon.

Road

Road should be selected when operating on compacted, smooth surfaces like asphalt, gravel or dirt roads/paths.

Water

Water should be selected when operating in depths of water that will float the vehicle. This pressure will help maximize the vehicles top speed when traversing through water.

Trail

Trail should be selected when operating on loose, dry soil or areas where an established road does not exist.

Mud

Mud should be selected when operating in wet, loose soil where the water depth is not sufficient to float the vehicle. The decrease in pressure will decrease contact pressure and improve traction.

Snow

Snow should be selected when operating on snow covered terrain, loose/deep conditions. The decrease in pressure will decrease contact pressure and improve traction.



Display - Tire Inflation System

Up Arrow

When the Up Arrow key is depressed, the target tire pressure will increase from the selected mode's default value. 3.5 psi is the maximum allowed pressure.

Down Arrow

When the Down Arrow key is depressed, the target tire pressure will decrease from the selected mode's default value. Minimum allowed pressure is 0.0 psi while the vehicle is not moving. Do not operate the vehicle with the tire pressure below 1.0 psi. With the engine "OFF", pressing and holding the "DOWN" arrow will deflate the tires to 0.0 psi.



CAUTION

Operating at pressures lower than the default terrain pressures may cause damage to the tires.

All terrain modes reset to the default pressure when you change to a different terrain setting.

If a tire pressure sensor circuit has an active error, the tire pressure value will be shown in red.

Display - Settings Screen

Settings Screen

From the Settings screen, the date, time, softkey color, and display brightness can be changed. Any changes made in the settings screen will be saved when you exit the screen.



Display - Settings Screen

Set Time/Date

Press the up/down arrows with your finger to change the Month, Day, Year, Hour Minute or Second value, then press "SET" to confirm your changes.

Soft Key Backlight Color

Drag the sliders to change the Soft Key backlight color. Moving a slider from left to right will increase the amount of that color in the Soft Key backlight.

Display Brightness

Drag the slider to increase or decrease the brightness of the display screen and soft key backlight.

NOTE: The soft key Backlight Color and Display Brightness can also be adjusted when in Night mode by depressing the Night mode soft key and adjusting the settings.

Vehicle Info Screen

The Vehicle Info Screen can be customized and configured to display multiple vehicle, engine or chassis data items in a gauge or list format.

To change one of the three gauges shown on the left side of the screen, tap the gauge and then select the item to display by tapping on it from the list.



Display - Settings Screen

To change one of the eight values shown in the list, tap the desired location, then select the item from to display by tapping on it from the list.



Display - Manual Screen

Manual Screen

The Manual Screen contains pre-loaded content that can be viewed and displayed on the monitor.

To access stored content, click the “SELECT MANUAL” button.

- Toggle through content using “UP” or “DOWN” buttons.
- Pressing “ENTER” will load selected manual.



The display screen has touch functionality which will allow you to scroll through the content by sliding the scroll bar from left to right or by using the arrows. Once desired page is displayed, press “DESIRED PAGES” button.



Display - Camera Screen

Camera Screen

The Camera Screen can be accessed at any time to display the rear facing camera. The camera will be displayed anytime the vehicle is shifted to reverse. The camera screen can be exited while shifted into reverse by touching any of the soft keys to view another screen.

To change one of the three gauges shown on the left side of the screen, tap the gauge and then select the item to display by tapping on it from the list.



Display - Diagnostic Screen

Diagnostic Screen

The Diagnostic Screen displays active faults from ECUs, Input values from sensors and Output functions to activate circuits.

Faults can be generated from a fault in the Engine ECU, Steering Control Unit (SCU), and Cooling Fan Unit (CFU). If a fault becomes active, the display will automatically change to the Diag. Screen and an audible alarm will sound. The Diag. Screen cannot be exited until the fault has been acknowledged by pressing the soft key next to the ACKN FAULT icon.



WARNING

IMMEDIATELY STOP OPERATION IF A FAULT IS DISPLAYED. SEE FAULT SECTION IN THIS MANUAL FOR MORE INFORMATION OR CONTACT DEALER FOR POSSIBLE SERVICE.

Display - Diagnostic Screen

Engine ECU faults will be displayed at the top of the display screen, as shown in the image below. If there is more than one active fault, the list will scroll automatically, or they can be manually viewed by using the up/down arrows. There will also be an icon displayed at the top of the screen to indicate an active fault exists.



Display - Diagnostic Screen

Steering Control faults will be displayed when active in the lower portion of the screen. When a SCU fault is active, the text will be black, inactive faults are gray in color. There will also be an icon displayed at the top of the screen to indicate an active fault exists.



Cooling Fan faults and data items will be displayed when active in the lower portion of the screen. When a CFU fault is active, the text will be black, inactive faults are gray in color. There will also be an icon displayed at the top of the screen to indicate an active fault exists.



Display - Diagnostic Screen

The Inputs Screen displays current values of sensors or circuits that communicate with one or more of the ECUs on the vehicle.



The Outputs Screen displays current state of the outputs.



To change one of the three gauges shown on the left side of the screen, tap the gauge and then select the item to display by tapping on it from the list.

Display - Night Screen

Night Screen

The Night Screen changes the display color and brightness settings to allow for different colors or screen brightness level. Press the soft key to the left of the Night icon to activate or deactivate Night mode.

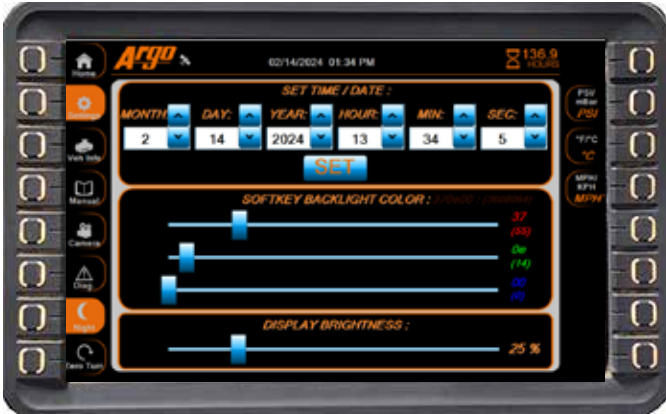

To change the soft key Backlight Color or Display Brightness for Night mode, first activate Night mode by pressing the soft key to the left of the Night icon. Next, press the soft key to the left of the Settings icon, then perform the desired changes to the display settings. Once you have completed the desired changes, navigate to any of the other screens by pressing the corresponding soft key.

Display - Zero Turn

Zero Turn

The Zero Turn function activates the vehicle steering when the vehicle is NOT moving. When doors are in the “CLOSED” position, the Zero Turn function button does not need to be depressed. Doors must be in the “CLOSED” position, the engine must be running, the brake pedal depressed and the transmission in D, OD, or R gear position to perform a zero turn.



WARNING

When performing a zero turn in reverse, the vehicle will turn opposite of the direction the steering wheel is turned.

If zero turns are performed for extended periods, battery voltage may drop causing the system to derate the steering output.

Door Switches

If either of the doors (front or side) are open, the door ajar icon will illuminate on the display. If the doors are open or a door switch fails, the Zero Turn function button may be depressed to bypass the door switch. Press the Zero Turn icon or soft key to the left of the zero turn icon to activate. The engine must be running, the brake pedal depressed and the transmission in D, OD, or R gear position to perform a zero turn. If there is no steering wheel angle detected for 3 seconds, the zero turn function will deactivate.



DOOR
AJAR

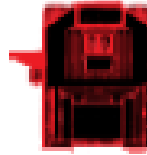

DOOR
AJAR



SECTION 4

XTV Operation



ATTENTION!

THE PARKING BRAKE MUST BE RELEASED BEFORE DRIVING

Pre-Operation Check and After-Operation Maintenance

- .- Check fuel level, fill if necessary
- Check the coolant level and add coolant if necessary (engine should be cold).
- Check brake fluid level, add if necessary.
- Check lights and alarm device operations.
- Remove dust and debris from the radiator suction grille, engine duct grille and from engine compartment as needed.
- Check wheels and tires for damage.
- Check tire pressure accuracy (depending on specified conditions of use).
- Check CVTs and belts.
- Check gauges and warning indicators.
- Check warning labels for damages. Replace if worn or damaged.
- Check seat belt condition.
- Check brake system.
- Be sure to drain water from the hold and chassis after driving in water.
- Remove the drain plugs from the hold if vehicle is to be stored outside.
- Start the engine and allow engine to warm up. With the engine running, check operation of all devices.
- Check bilge pump.
- Check engine oil.
- Check transmission oil level.
- Check chain case oil level.
- Ensure tail gate and ladder is in the closed/stowed position.
- Ensure doors operate and latch securely.



WARNING

DO NOT OVERLOAD THE VEHICLE. SEE SPECIFICATIONS SECTION. SERIOUS INJURY OR DEATH MAY RESULT.

Entering and Exiting the XTV Cab

- 1 - Front windshield
- 2 - Front door/ladder
- 3 - Tire tread
- 4 - Side door/step
- 5 - Side window/door
- 6 - Emergency hatch

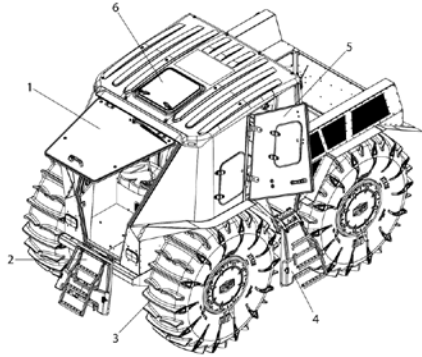

To Enter the XTV Cab from the Front

- Push button and lift front window.
- Release door latch to open the front door, lowering it down to the stop.
- Put your foot on the boarding ladder.
- Grasp the hand holds located on each side of the door entrance.

NOTE: DO NOT grasp the steering wheel as a hand hold to enter the vehicle.



WARNING

Turning the steering wheel with engine running and the brake pedal depressed will activate a zero-turn. This may cause personal injury while entering or exiting the vehicle.

- Close and latch the door and windshield before operating the vehicle.
- Position yourself in either driver or passenger seat.
- Fasten seat belt.

To Enter the XTV Cab from the Side

- Depress the door latch to open the upper side door window.
- Release the latch to open the side door, lowering it down to the stop.
- Put your foot on the boarding ladder.
- Grasp the hand holds located on each side of the door entrance.
- Close and latch the ladder door.
- Close and latch the entry door.
- Position yourself in either rear seat.
- Fasten seat belt.



WARNING

To avoid possible injuries, ensure shoes/boots and inside door surfaces are free from any possible slipping/tripping hazards.

To Exit the XTV Cab

- Place vehicle in the "N" (Neutral) position.
- Engage parking brake.
- Stop the engine.
- Release seat belt.
- Remove the key from ignition to prevent unauthorized vehicle use.
- Exit the cab in reverse sequence to entrance.

Emergency Exit from the XTV Cab

In an emergency, you can exit the cab through the main door, side door or emergency hatch.

To open the emergency exit hatch, turn the hatch handles to unlock the hatch. Then lift the hatch window open until it rests back on the vehicle roof.



Front Seat Adjustment

To adjust the driver and/or passenger seats:

- Release the adjustment lever located in the front of the seat and slide seat forward or backward into desired position.
- To lock the seat, release the adjustment lever.

To tilt or adjust the driver and/or passenger seatback:

- Release the adjustment lever located on the side of the seat and tilt/adjust the seatback forward or backward into desired position.
- To lock the seatback, release the adjustment lever.

The seat must engage into the retainers and lock into position.

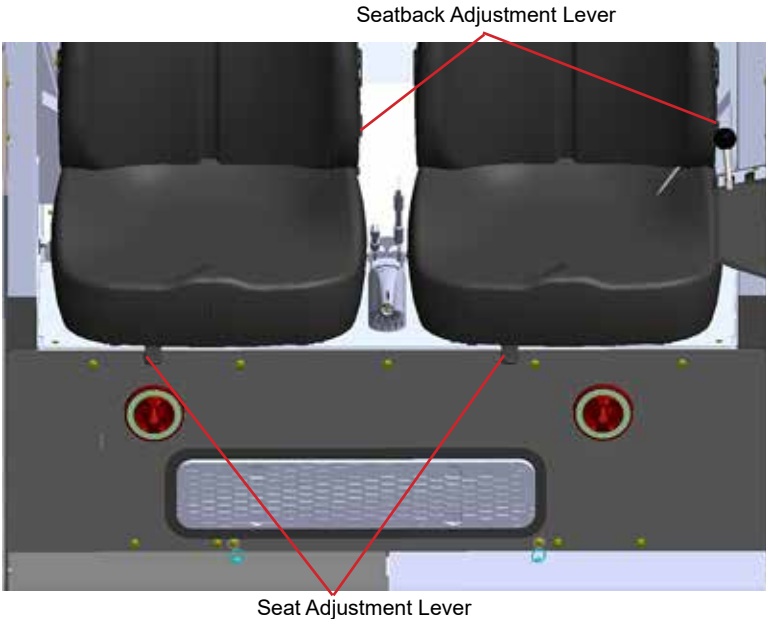

WARNING

Ensure the seat is secure and locked into position before operation. Serious injury or death could result if the seat is not properly secured.

General Driving

To operate the XTV, once the engine has been started and allowed to warm up:

- Ensure driver and passenger seat belts are fastened and cargo is secured.

NOTE: The engine must be at idle before attempting to shift the transmission.

- With the brake pedal depressed, release the parking brake.
- Place gearshift lever in desired gear position (D, OD or R).
- Slowly release brake pedal.
- Slowly depress the accelerator pedal to desired RPM and speed.



Braking

To apply braking to the XTV:

- Release accelerator pedal.
- Gently depress the brake pedal.
- Place gearshift lever in "N" (neutral) position after coming to a complete stop.
- Apply the parking brake before releasing the brake pedal.



Shifting



CAUTION

NOTE: The engine must be at idle speed (1100 RPM) before attempting to shift the transmission.

- With the brake pedal depressed, release the parking brake.
- Place the gearshift lever in the desired gear position (D, OD, or R).

NOTE: Overdrive (OD) is intended for road speed use with low load on the vehicle.

- Slowly release the brake pedal.
- Slowly depress the accelerator pedal to desired RPM and speed.



To shift gears during operation of the XTV:

- Release accelerator pedal.
- Gently depress the brake pedal until the vehicle comes to a complete stop.
- Place the gearshift lever in the desired gear position (D, OD, or R).

Fueling the XTV

To add fuel to the XTV:

- Remove fuel cap.
- SLOWLY add desired amount of diesel fuel - DO NOT OVERFILL.
- Replace fuel cap and tighten securely.



WARNING

- NEVER fill the fuel tank while the engine is running or hot.
- Always use an original fuel cap or OEM (Original Equipment Manufacturer) replacement.
- NEVER fill the fuel tank while the XTV is inside a building without proper ventilation.
- DO NOT OVERFILL.

Wheel Canisters

To add liquid to the wheel canisters:

This XTV is equipped with wheel canisters located within the wheels.

To fill wheel canisters:

Wheel must be oriented top-dead-center to FILL.

- Using 3/4" ratchet (or equivalent), remove wheel canister plug.
- Add desired amount of liquid.
- Clean plug threads (if required).
- Apply thread sealer to plug threads.
- Replace plug and tighten securely.

To remove liquid from the wheel canisters:

Wheel must be oriented top-dead-center for liquid REMOVAL.

- Using 3/4" ratchet (or equivalent), remove wheel canister plug.
- Using a suitable auxiliary pump (not supplied with vehicle), remove desired amount of liquid from the wheel canister.
- Clean plug threads.
- Apply thread sealer to plug threads.
- Replace plug and tighten securely.



Wheel Canister Plug

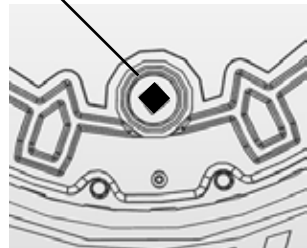

Engine Start

- Engage parking brake lever.
- Place gearshift lever in the “N” neutral position.
- Turn “ON” battery disconnect switch.
- Insert the key into the ignition switch and turn it to the “ON” position.
- If the the glow plug lamp is illuminated on the display, allow adequate time for the glow plug lamp to go out.
- When glow lamp goes out, turn the key to the “START” position.

After the engine starts, immediately release the key to the “ON” position.

Allow engine to warm up at idle rpm without loading.



WARNING

- **Some engine parts may be hot.**
- **The engine can release hot exhaust gases.**
- **Keep fuels and lubricants at a safe distance.**
- **If possible, avoid starting the engine on slopes.**
- **Do not use ether or any other fluids to start the engine, it may cause serious damage to the engine.**



CAUTION

If oil pressure indicator light is on after initial start, immediately stop the engine and check:

- If there is enough engine oil.
- If the engine oil is contaminated.
- If the wiring is faulty.



CAUTION

If oil pressure indicator alarm is activated, immediately stop the engine and contact your service center.

If the engine does not start within 10 seconds after the key is rotated to the “START” position, wait for 30 seconds and then begin the engine starting sequence again. Do not allow the starter to run continuously for more than 10 seconds or starter damage may occur.

Cold Weather Starting

If the ambient temperature is below 23°F (-5°C) and the engine is very cold, start in the following manner:

- Engage parking brake lever.
 - Place gearshift lever in “N” neutral position.
 - Turn “ON” battery disconnect switch.
 - Insert the key into the ignition switch and turn it to the “ON” position.
 - If the the glow plug lamp is illuminated on the display, allow adequate time for the glow plug lamp to go out.
 - When glow lamp goes out, turn the key to the “START” position.
- After the engine starts, immediately release the key to the “ON” position. Allow the engine to warm up at both high and low ambient temperatures. An insufficiently warmed-up engine can shorten its service life.

If engine does not start within 10 seconds after the starter switch is turned to the “START” position, wait for 30 seconds and then begin by preheating the engine and starting the engine sequence again. Do not allow the starter to run continuously for more than 10 seconds or starter damage may occur.

Engine Stop

- Release pressure from accelerator pedal (engine automatically goes into idle mode) and let run for 1-3 minutes.
- Turn the key to the “OFF” (STOP) position. Engine will stop.



CAUTION

When engine runs within the rated output range, the color of exhaust gases remains colorless.

If, at sharp acceleration, the rpm speed increases to maximum level, exhaust gases may be tinted a slightly dark color which is not a sign of engine failure. If the engine exhaust gases remains a tinted dark color at normal operation, engine failure may be possible. Contact your local dealer.



CAUTION

Immediately stop the engine if:

- Engine suddenly slows down or accelerates on its own.
- Unusual noises suddenly appear.
- Oil pressure warning indicator lights up or the temperature gauge registers the emergency coolant temperature or the audio signal is heard.
- Reverse engine operation has occurred.

Reverse Engine Operation (Crankshaft rotation in the opposite direction)

Reversed engine operation during crankshaft rotation in the opposite direction must be stopped immediately since engine oil circulation is cut quickly, leading to engine failure.



Signs of reversed engine operation:

- Lubricating oil pressure drops sharply.
- Oil pressure warning indicator lights on.
- Due to the intake and exhaust sides being reversed, the sound of engine changes, and exhaust gases will come out of the air filter.
- Loud knocking sound is heard (detonation).

Remedies:

- Immediately stop the engine and apply the parking brake.
- After the engine stops, check the air filter, intake rubber tube and replace these parts, if necessary.

Tire Inspection during Operation

Tire durability and reliability are determined by following the operating conditions established norms and proper tire maintenance.

Tire Operating Conditions (Normal)

Acceptable tire pressure for most typical driving conditions is outlined in the table below. The tread pattern wear limit at center point of lug shall not be less than 1" (25 mm). **It is not recommended to drive along paved and dirt roads at the internal tire pressures less than specified in the table.**

Tire designation	Internal tire pressure, due to the maximum loading, psi	Maximum speed, mph (km/h)
71" x 23"-25"	3.5 psi (181 mm Hg)	25 mph (40 km/h)

The specific value of the pressure while driving off-road is selected by the driver depending on type and soil, snow, waterlogged terrain state. In this case, the tire pressure should provide the XTV with optimal performance under such conditions.

Conditions	Preset Tire Pressure	
	psi	mm Hg
Road	3.3	171
Water	3.0	155
Trail	2.5	129
Mud	2.0	103
Snow	1.5	78

General Cases of XTV Operation

Proper XTV operation is one of the most important factors for increasing its service life and trouble-free operation. XTV operation is possible only after engine is warmed up and display is checked for any error codes, proper engine oil pressure, proper engine RPM, adequate fuel level, etc. While moving, constantly observe the display for updated vehicle performance. Of particular importance is the right choice of tire pressure. The specific value of the pressure while driving is selected by the operator, depending on terrain conditions. In this case, the recommended tire pressure should provide the XTV with optimal performance under such conditions.

New XTV Break-In Procedure

To obtain long term, trouble free service from your vehicle, observe the following break-in guidelines:

- Vary the speed of the vehicle for the first 20 engine hours. Avoid full throttle operation during break-in period.
- Check engine and transmission oil levels periodically during break-in period.
- Find a terrain with suitable sand, soil, dirt roads, etc., and the natural inclines and slopes most complying to vehicle operating condition requirements.
- During low ambient temperatures, start moving after complete engine warm up.
- Do not overload the XTV.
- Check the batteries and, if necessary, clean the terminals and grease them.
- Check fasteners and connections, tighten as necessary.
- Listen to the engine and check the display screens for any abnormalities.

If the engine operates within the rated power, exhaust gases remain colorless, but if, by sharply pressing the accelerator pedal the speed increases to maximum values, exhaust gases may be slightly darkened which is normal operation.

During the break-in period, limit the maximum speed to 18 mph (30 km/h).

The payload must not exceed 75% of the maximum payload.

It is not recommended to operate the engine above the idle speed in neutral during engine start and warm-up.

Operation in Remote Areas

The below items are recommended before traveling long journeys or trips to remote areas:

- First aid kit
- Survival gear
- Protective clothing and footwear
- Waterproof matches
- Flares
- Means of communication
- Adequate supply of fuel (diesel)
- Fire extinguisher
- Basic tools and spare parts

Before heading out to a remote area, it is necessary to perform complete XTV inspection, adjustment and lubrication. Ensure vehicle is in good working condition. Equipment and supplies shall be selected taking into account climatic and weather conditions.

In remote areas, follow safe driving rules. Detour the area which may be impassible.

Driving on Sandy Areas, Loose Soil and Snow



WARNING

DO NOT OVERLOAD THE VEHICLE. SEE SPECIFICATIONS SECTION. SERIOUS INJURY OR DEATH MAY RESULT.

Depending on soil or snow cover density, it is necessary to select the appropriate tire pressure. Drive should be the gear used for operation in these conditions.

It is necessary to keep a smooth moving XTV, avoiding jerks and stops. Smooth turns making large radius turns without reducing speed. While following another vehicle, follow at a safe distance in their tracks at a distance of no less than 150 ft (46 m). Before moving along deep fresh snow, operator must balance the load in the XTV. If the wheels start slipping, it is recommended to move backwards and try to bypass difficult parts of the terrain. Avoid allowing the wheels to spin when forward motion has stopped.

Example for Land Navigation:

Current Load Capacity:

Operator 240 lbs

Passengers (3 @ 200 lbs) 600 lbs

Cargo 240 lbs

Total: 1080 lbs

Max Load Capacity: 2645 lbs

- 1080 lbs (Current Load Capacity)

= 1565 lbs (Remaining Load Capacity Available)

Driving Uphill and Downhill

- Do not operate XTV on slopes steeper than 35°.
- Inspect hills for slippery or loose surfaces before attempting to climb or descend.
- Keep hands, feet and all body parts in the XTV at all times.
- Ensure all cargo is securely fastened within the vehicle.
- Note that towing, braking and traction are greatly diminished during hill climbing or descending.
- Keep XTV straight when climbing and/or cresting and descending hills.
- Do not stop or start suddenly or over-accelerate on hills. Loss of control and rollover could result.
- Before climbing, it is necessary to engage Drive gear which will provide the maximum traction to the wheels.
- If the XTV loses power or traction and stops while climbing a hill, immediately apply the brake and reverse slowly down the hill, maintaining a straight, downhill line of travel. Attempting to turn the XTV could result in a rollover.
- When descending a hill, over-application of the brake may cause skidding and loss of control. Apply the brakes slightly to aid in slowing down.

Driving on Waterlogged Terrain

The XTV is able to overcome all kinds of waterlogged areas. Operating skills are required. It is recommended to overcome the waterlogged terrains using the shortest ways possible. The corresponding tire pressure must be observed.

Passing Water Barriers



WARNING

DO NOT OVERLOAD THE VEHICLE. SEE SPECIFICATIONS SECTION. SERIOUS INJURY OR DEATH MAY RESULT.

NOTE: Know your local laws and regulations related to water navigation.

The XTV is able to cross water by floating and must be done carefully, without jerks and any sharp turns.

Moving by floating, as well as into and out of the water, such conditions must be followed:

- Ensure hold drain plugs are installed.
- Always wear a life jacket before attempting water barriers.
- Avoid floating in water with current, waves, and/or strong winds.
- At the location of entering the water, bank must be free of obstacles. Move into the water along a smooth descent.

NOTE: It is recommended to activate the bilge pump from time to time while performing water navigation. Do not allow pump to run continuously.

- In case of leak, go ashore. Drain the water by removing the hold drain plugs and repair the area that is causing the leak.
- Reinstall hold drain plugs.
- Do not try to overcome wide water barriers. If possible, stay close to shoreline
- To go ashore, choose a relatively flat spot, free of rocks and other obstacles. Align the XTV so that front wheels get out of water simultaneously.

NOTE: It is recommended the XTV be cleaned and rinsed thoroughly after encountering and/or navigating water or salt water of any kind.

Example for Water Navigation:

Current Load Capacity:

Operator	210 lbs
Passengers (2 @ 200 lbs)	400 lbs
Misc cargo/supplies	106 lbs

Total: 716 lbs

Max Load Capacity: 1600 lbs

- 716 lbs (Current Load Capacity)

= 884 lbs (Remaining Load Capacity Available)

Passing Water to Ice Barriers



WARNING

Water to ice navigation is dependent on operator ability, load distribution of passengers/cargo, and conditions of the ice. Extreme caution or avoidance of these conditions is recommended. **SERIOUS INJURY OR DEATH MAY RESULT.**



WARNING

DO NOT OVERLOAD THE VEHICLE. SEE SPECIFICATIONS SECTION. SERIOUS INJURY OR DEATH MAY RESULT.

Passing Water to Ice Barriers (Continued)

Using the ARGO on ice-covered bodies of water is potentially hazardous.

USE EXTREME CAUTION. Exposure to cold water reduces a person's chance of survival. Protective clothing, such as a marine survival suit will significantly decrease the effect of exposure in frigid water.

If the vehicle breaks through the ice, it will float in the water, provided that there are no leaks in the body, the drain plugs are in place and vehicle is not taking on water through any body openings. However, there is a risk of the vehicle tipping, particularly if the load is unbalanced. Be prepared to shift occupants' weight for balance.

Getting back onto safe ice depends on conditions (snow covered, smooth, rough, wet, etc.) and expertise of the operator. Be especially careful to prevent water from entering the vehicle.

- Balance of cargo and passenger will have an effect on the ability to traverse from water to ice.
- Keep openings, like air intakes/exhaust, etc. above the water line.
- Keep the bilge pump running.
- Avoid getting the wheels on only one side onto the ice surface as water could enter over the opposite side of the vehicle.
- Avoid turning as the Argo is climbing out of the water to avoid vehicle tip-over.
- Be wary of currents which may affect the vehicle operation.

If you feel that you may not be able to get the vehicle back onto safe ice or land, you might consider staying put to await rescue. This may be safer than trying to leave the vehicle to walk over thin ice.

Example for Water to Ice Navigation:

Current Load Capacity:

Operator	210 lbs
Passengers (2 @ 200 lbs)	400 lbs
Misc cargo/supplies	106 lbs
Total:	716 lbs

Max Load Capacity:

882 lbs

- 716 lbs (Current Load Capacity)
- = 166 lbs (Remaining Load Capacity Available)



CAUTION

**DO NOT
REMOVE THESE
CHAIN BOX PLUGS
TO DRAIN WATER**

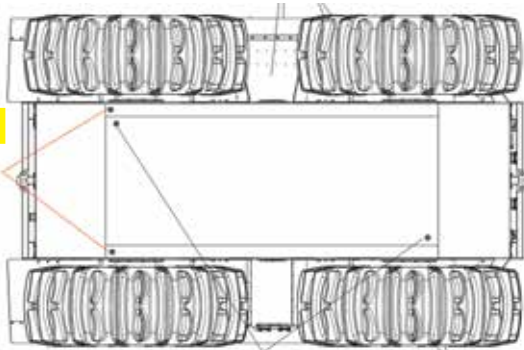

Water Drain Hole Plugs

SECTION 5

Technical Maintenance

Proper maintenance of this vehicle is important for optimum performance. Follow the Maintenance Schedule and all ensuing maintenance instructions / information.

If, at any time, abnormal noises, vibrations, or improper functioning of any component of this vehicle is detected, **DO NOT OPERATE THE VEHICLE**. Take the vehicle to an authorized ARGO Commercial dealer for inspection, adjustment or repair.

If the owner/operator does not feel qualified to perform any of these maintenance procedures or checks, take the vehicle to an authorized ARGO dealer for professional service.

NOTE: The following instructions and information refer to specific items in the maintenance and care of this vehicle.

Technical Maintenance Types and Frequency

XTV technical maintenance includes control and diagnostic, grease, adjustments and other maintenance. Frequency and types of maintenance performed during technical maintenance are provided below:

NOTE: Depending on the use of the XTV, more frequent maintenance may be required than what is called out on the chart below.

	Maintenance Procedure	Engine Hours or Frequency											
		Daily	50	250	500	1000	1500	1750	2000	2250	2500	2750	3000
1	Check the engine oil level. Fill if needed.	√											
2	Check the coolant level and fill if needed (in a cold engine)	√											
3	Remove debris (leaves, etc.) from the radiator grille, airflow grille, and engine bay	√											
4	Check tire integrity and pressure (depending on operating conditions)	√											
5	Check wheel bolt to hub torque		√	√									
6	Check wheel bead lock torque		√	√									
7	Check instrumentation and light indicators	√	√										
8	Check seat belts	√	√										
9	Check for damaged warning labels. Replace as needed.	√	√										

Technical Maintenance Types and Frequency (continued)

	Maintenance Procedure	Engine Hours or Frequency											
		Daily	50	250	500	1000	1500	1750	2000	2250	2500	2750	3000
10	Check main braking system and parking brake	√	√										
11	Check engine and transmission performance	√	√										
12	Check transmission oil level	√	√		√		√			√			√
13	Change the engine oil		√	√	Every 250 hours								
14	Replace oil filter		√	√	Every 250 hours								
15	Check fuel lines and clamps. Replace if needed.		√		√	Every 500 hours							
16	Check battery wires and terminals. Lubricate terminals.		√		√	Every 500 hours							
17	Ensure radiator, reservoir tank and other cooling system connections are properly secured and tight		√			√			√				√
18	Check/Replace engine air filter		√	Service as Indicated on the Air Filter Service Gauge									
19	Check brake pads. Replace if needed.		√	Every 250 hours									
20	Adjust parking brake		√	Every 250 hours									
21	Replace fuel filters		√		√	Every 500 hours							
22	Remove sediment from fuel tank				√	Every 500 hours							
23	Replace engine pulley drive belt				√	Every 500 hours							
24	Clean radiator outer surface. Ensure radiator is securely mounted.				√	Every 500 hours							
25	Change the transmission oil		√	Every 250 hours									
26	Check/tighten threaded connections		√	Every 250 hours									
27	Replace the exhaust system				√	Every 750 hours							

Technical Maintenance Types and Frequency (continued)

	Maintenance Procedure	Engine Hours or Frequency											
		Daily	50	250	500	1000	1500	1750	2000	2250	2500	2750	3000
28	Check electrical wiring for defects or loose connections	Every year											
29	Check batteries. Replace if needed.	Every three years											
30	Replace engine cooling system pipes, sleeves and clamps.	Every three years or 3000 hours											
31	Check the tire inflation system pipes and clamps.												
38	Replace the brake fluid in the braking system												
39	Grease upper front and upper side door window hinges	Every 250 hours											
40	Lubricate door latches	Every 250 hours											
41	Read and resolve ECU errors.	Complete a first diagnostic at 50 hours and a subsequent diagnostic every 250 hours.											

The intervals shown on the schedule are based on average operating conditions. Vehicles which are subjected to severe use and wet or dusty conditions will require more frequent servicing. Use only Argo replacement parts to ensure safe operation of the vehicle and to comply with the warranty coverage.

Measurements for Adjustments and Control

Parameters	Measurement limits
Engine idle RPM	1100 rpm
Oil pressure in the engine lubrication system at idle	11.6 psi (0.8 kPa)
Oil pressure in the engine lubrication system at maximum RPM	43.5 psi (3.0 kPa)
Coolant temperature under normal operating conditions	180°F-207°F (82°C-97°C)
Maximum coolant temperature	230°F (110°C)
The coolant level in the expansion tank on the cold engine must be at the fill mark (see item: Refilling of Coolant)	by mark
Level of brake fluid in the master cylinder	1/2" (13 mm) from top of reservoir
Level of oil in the chain drive oil tanks	1.4" - 2.4" (35 - 60 mm) from bottom of tank
Transmission fluid level	Dipstick
Engine Oil	Dipstick
Washer Fluid	by mark

Filling Volumes, Petroleum Products and Lubricants

Junction Point Name	Filling Name	Quantity (L, gal.) (Number of Points)
Fuel		
Fuel Tank	Diesel fuel №2-D (ASTM D975) EURO (EN 590:2004)	26.5 gal (100 L)
Engine Oils		
Engine	Engine oil of API quality degree: not less than CJ. SAE viscosity grade: -0W-30 (from -30°C to +20°C) (-22°F to 68°F); -0W-40 (from -30°C to +35°C) (-22°F to 95°F); -5W-40 (from -25°C to +35°C) (-13°F to 95°F); -10W-30 (from -20°C to +30°C) (-4°F to 86°F); -10W-40 (from -20°C to +35°C) (-4°F to 95°F); -15W-40 (from -15°C to +45°C) (-5°F to 113°F)	6.6 qt (6.3 L)
Drive Chain (Gearbox)	15W40 (API CK-4 / ACEA E6)	5 gal (19 L) - Right 5 gal (19 L) - Left
Transmission	Mobil 1 LV ATF HP or equivalent	3.4 qt (3.25 L)
Operating Fluids		
Engine coolant	Solution of 50% non-freeze agent G11 (ethylene glycol) and 50% distilled water	1.59 gal (6 L)
Braking system	DOT 4	6 oz. (177 ml)
Battery Terminals	Mobil Grease XHP 222 or Lithol 24	As Required
Wheel Hubs		As Required
Miscellaneous		
Wheel Canisters		4 x 10 gal (4 x 38 L)

Engine Oil Level Check



WARNING

To avoid personal injury, be sure to stop the engine and engage parking brake before checking oil level and/or changing engine oil.

- Park the vehicle to a flat surface.
- Start the engine and run until it reaches normal operating temperature.
- Stop the engine.
- Let cool for 5-10 minutes.
- Remove the 4 fasteners securing the engine access panel and remove the panel.
- Remove the oil level dipstick located beside the oil filter on the side of the engine.
- Clean the indication line of the dipstick with a clean cloth.
- Replace dipstick.

NOTE: If the dipstick doesn't slide in, rotate it 180°.

- Remove dipstick and check oil level.
- Check if oil level appears between the upper limit (A) and the lower limit (B) on the dipstick.
- If engine oil appears below the lower limit (B) or does not appear on the dipstick at all, remove the oil filler cap and add new oil to the prescribed level.

NOTE: DO NOT OVERFILL

After adding oil, wait more than 5 minutes and check the oil level again. It takes some time for the oil to drain down into the oil pan.

- Check condition of engine oil. If contaminated, replace with new oil.



CAUTION

Ensure foreign substances/debris is not allowed to enter the engine when checking/filling engine oil.

Exceeding the upper limit of the dipstick may cause engine damage. If you have exceeded the upper limit, drain until the engine oil level is indicated between the upper and lower limits on the dipstick.

Do not use unspecified engine oil additives.

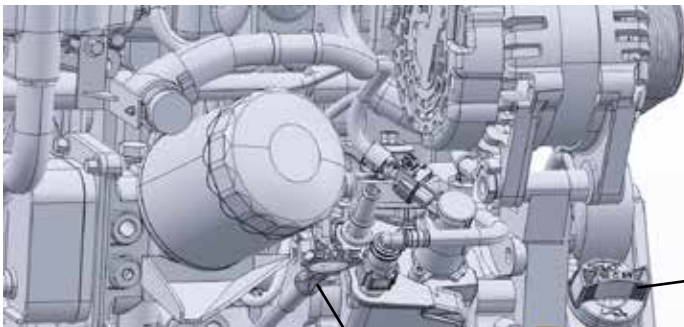

Oil dipstick

Oil fill cap

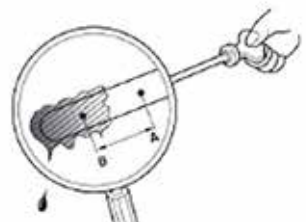

Engine Oil Change



WARNING

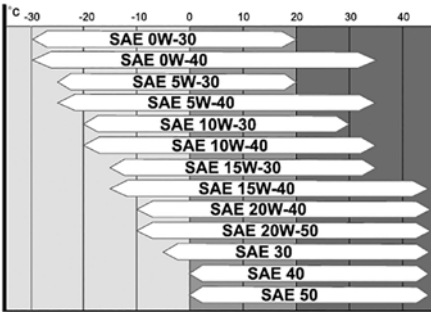

NOTE: Engine oil must have properties of API CJ classification CJ grades or higher and SAE viscosity grade in accordance with the ambient temperature, in which vehicle is mainly operated.

Ensure XTV is parked on a flat level surface with parking brake engaged.

- The engine should be warmed to operating temperature.
- Let the engine cool for 5-10 minutes.
- Remove the four thumb screws securing the Engine Mid Access Panel and remove the panel.



WARNING

To prevent personal injury, use CAUTION as surfaces may be hot and may cause serious injury.

- Remove the engine oil dipstick.
- Insert a 1/4" vacuum extractor suction line into the dipstick hole until the suction line has reached the bottom. **NOTE: May require hose positioning and depth adjustments to extract all the fluid.**
- Remove extractor hose and insert dipstick.
- Position a small drip tray under the oil filter drip funnel.
- Remove the oil filter.
- Clean any oil or debris from the oil filter funnel and sealing surface on the engine.
- Lubricate the new oil filter seal using fresh engine oil and install filter. Tighten securely.
- Remove the oil fill cap.
- Using a flexible long funnel, add the appropriate amount and type of engine oil until the oil level is between the upper and lower operating range dimples on the engine oil dipstick.
- Reinstall oil fill cap.
- Turn the ignition switch to the "RUN" position to allow the display to fully power up.
- Start the engine, check to ensure the oil pressure gauge indicator is within the operating range.



CAUTION

If oil pressure is NOT within operating range within 10 seconds, turn the engine off. Contact your Argo dealer.

Engine Oil Change

- Remove the engine oil dipstick.
- Clean any oil from the dipstick and reinsert.
NOTE: If the dipstick doesn't slide in, rotate it 180°.
- Remove the engine oil dipstick and ensure engine oil is between the upper and lower operating range dimples. Add additional oil if necessary.
DO NOT OVERFILL.
- Reinstall the Engine Mid Access panel and install thumb screws.

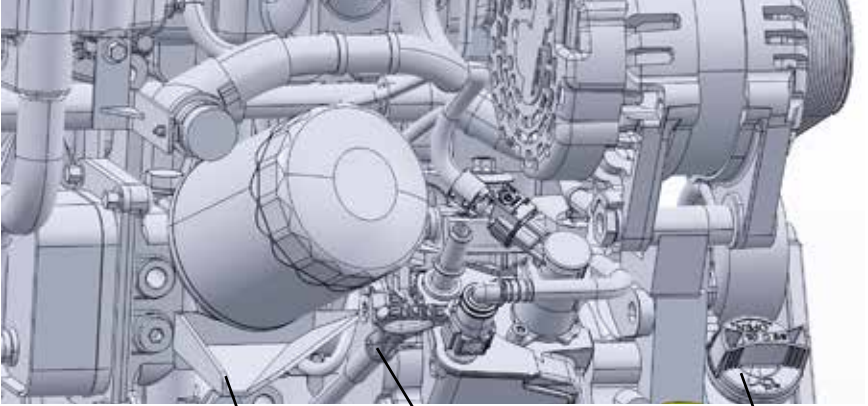

Drip funnel

Oil dipstick

Oil fill cap



Checking and Changing Transmission Oil



WARNING

Ensure XTV is parked on a flat level surface, transmission in “N” neutral gear with parking brake engaged and wheels chocked.

Checking Transmission Fluid Level:

- Remove fasteners securing the engine compartment close off panel and remove the panel.
- Remove transmission dipstick by carefully reaching between the AC belt and muffler.



WARNING

To prevent personal injury, use CAUTION when reaching for transmission dipstick as surfaces may be hot and may cause serious injury.

- Inspect fluid level. The fluid level should be between the upper and lower operating range hash marks.

Adding Transmission Fluid:

- If the fluid is below the lower operating range hash mark, remove the transmission breather vent at the top/front of the transmission.
- Add the required amount of Mobil 1 LV ATF HP or equivalent Transmission Oil to bring the fluid within the upper and lower operating range hash marks.
- Reinstall the transmission dipstick and breather vent.

Transmission Breather Vent

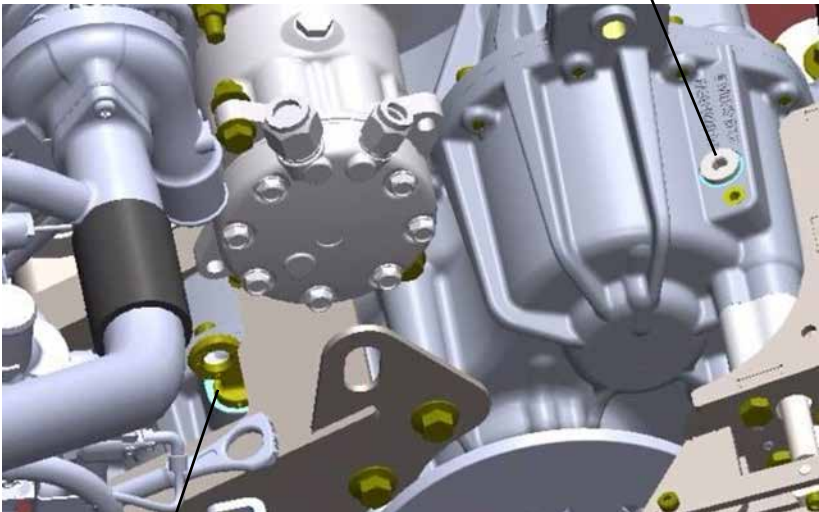

Transmission Dipstick

Checking and Changing Transmission Oil

Changing Transmission Fluid (Vacuum Pump):

- With the transmission fluid at operating temperature, remove transmission dipstick by carefully reaching between the AC belt and muffler.

WARNING

To prevent personal injury, use **CAUTION** when reaching for transmission dipstick as surfaces may be hot and may cause serious injury.

- Insert a 1/4" vacuum extractor suction line into the dipstick hole until the suction line has reached the bottom of the transmission (approximately 8").
- Extract all fluid. **May require hose positioning and depth adjustment to extract all the fluid. This may take several minutes.**
- Remove the transmission breather vent at the top/front of the transmission.
- Add the appropriate type and amount of Mobil 1 LV ATF HP Transmission Oil to bring the fluid within the upper and lower operating range hash marks.
- Reinstall the transmission dipstick.
- Reinstall the transmission breather vent. Tighten securely.

Transmission Breather Vent

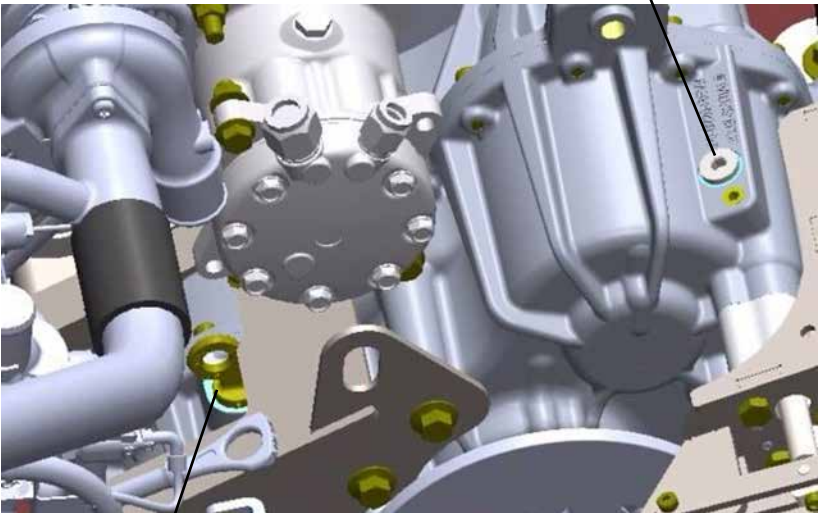

Transmission Dipstick

CVT Belt and Clutch Removal/Cleaning



WARNING

Ensure XTV is parked on a flat level surface, transmission in “N” neutral gear with parking brake engaged and wheels chocked.

CVT Belt and Clutch Removal/Cleaning:

- Remove fasteners securing the engine compartment close off panel and remove the panel.
- Using a suitable pry bar, apply pressure to the outer face of the driven clutch cam to compress the driven clutch until the CVT belt is at least 1” below the top of the sheaves.



- Remove the belt by rolling the CVT belt off the driven clutch and then remove from the drive clutch.
- Remove any belt material or debris from the clutch and clean with compressed air.

Chain Case Fluid Check



WARNING

Ensure XTV is parked on a flat level surface, transmission in the “N” (Neutral) position with parking brake engaged and wheels chocked.

- Remove the six (6) fasteners securing the rear floor panel in the rear of the cab.
- Locate the chain case caps on each side of the vehicle.
- Remove the caps and check fluid level using a stiff, rigid straight edge long enough to reach the bottom of the chain case, oil level should be 1 ¾ to 2” up from the bottom of the straight edge. Adjust if necessary.
- If necessary, add appropriate amount and type of chain case fluid on both LEFT and RIGHT sides.
- Replace fill caps. Tighten securely.
- Reinstall rear floor access panel.
- Reinstall fasteners securing rear floor access panel.

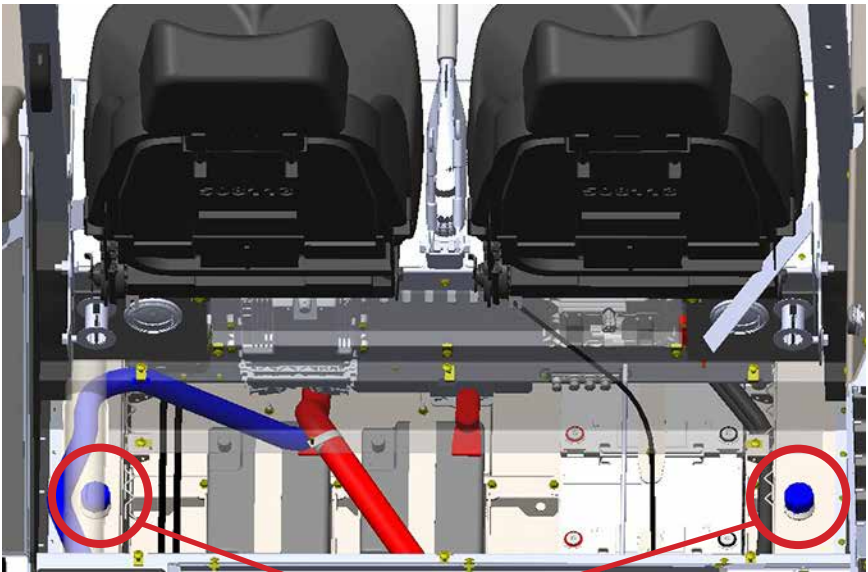

Chain Case Fill Caps

Chain Case Fluid Drain / Fill

Ensure XTV is parked on a flat level surface, transmission in the “N” (Neutral) position with parking brake engaged and wheels chocked.

Drain:

- Raise and block the front corners of the chassis or hull.
- Deflate the tires to allow for rear “sag”.
- Position a suitable drain pan below one side of the chain case drain plug.
NOTE: Must hold minimum 5 gallons (19 L).
- Remove the six (6) fasteners securing the rear floor panel in the rear of the cab.
- Locate the chain case caps on each side of the vehicle.
- Remove the fill caps.
- Remove chain case drain plug.
- Allow to completely drain.
- Apply a suitable thread sealer to the drain plug.
- Install chain case drain plug. Tighten securely.
- Repeat for opposite side.

Fill:

Ensure XTV is parked on a flat level surface, transmission in the “N” (Neutral) position with the parking brake engaged.

- Add appropriate amount and type of chain case fluid on both LEFT and RIGHT sides.
- Check fluid level using a stiff, rigid straight edge long enough to reach the bottom of the chain case, oil level should be 1 ¼ to 2” up from the bottom of the straight edge. Adjust if necessary.
- Repeat for opposite side.
- Replace fill caps. Tighten securely.
- Reinstall rear floor access panel.
- Reinstall fasteners securing rear floor access panel.

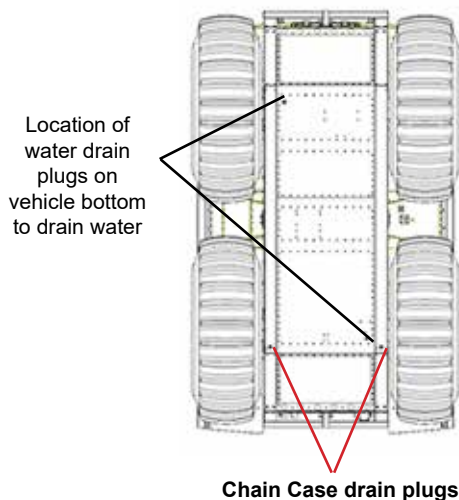

Fuel Filter Maintenance

Ensure XTV is parked on a flat level surface, transmission in “N” neutral gear with parking brake engaged and wheels chocked.

Remove the fasteners securing the Engine Main Access Panel (entire main panel) and remove the panel.



WARNING

To prevent personal injury, use CAUTION as surfaces may be hot and may cause serious injury.

Primary Fuel Filter Replacement:

- Disconnect the water in fuel sensor connector from the primary fuel filter.
- Disconnect the fuel heater connector from the primary fuel filter housing.
- Loosen the primary fuel filter. Clean any spilled fuel from the engine compartment.

NOTE: Before discarding fuel filter, remove the water in fuel sensor and O-ring from the filter and retain.

- Install the water in fuel sensor and O-ring to the new primary filter. Tighten securely.
- Lubricate the seal of the new fuel filter with clean diesel fuel and install the fuel filter. Tighten securely.
- Connect the water in fuel sensor connector to the primary fuel filter.
- Connect the fuel heater connector to the primary fuel filter housing.

Primary Fuel Filter



Water Sensor

Fuel Heater

Water Sensor



Fuel Filter Maintenance

Secondary Fuel Filter Replacement:

- Disconnect the fuel heater connector from the secondary fuel filter housing.
- Disconnect the fuel temp sensor connector from the secondary fuel filter housing.
- Loosen the secondary fuel filter. Clean any spilled fuel from the engine compartment.

NOTE: Before discarding fuel filter, remove the water in fuel sensor and O-ring from the filter and retain.

- Install the water in fuel sensor and O-ring to the new secondary filter. Tighten securely.
- Lubricate the seal of the new fuel filter with clean diesel fuel and install the fuel filter. Tighten securely.
- Connect the fuel heater connector to the secondary fuel filter housing.
- Connect the fuel temp sensor connector to the secondary fuel filter housing.

Secondary Fuel Filter



Fuel Heater

Water Sensor

Water Sensor



Bleeding the Fuel System:

- Remove the Engine Main Access Panel.
- Loosen the bleed screw located on top of the secondary filter housing and depress the priming plunger several times until full flow without air bubbles.
- Tighten bleed screw securely.
- Reinstall the Engine Main Access Panel.

Bleed Screw



Coolant Check/Refill



WARNING

To prevent personal injury, **DO NOT** remove the radiator cap or expansion tank cap while coolant is hot.

- Remove the four (4) thumb screws securing the engine radiator access panel located in the rear interior section of the cab.
- Clean any dirt or debris from the radiator cap and surrounding area.
- Remove the radiator cap.
- Coolant should be visible at the top of the radiator covering the cooling fins. If coolant is below this level, add 50/50 glycol coolant until the cooling fins are covered.
- Reinstall the radiator cap.
- Clean any dirt or debris from the reservoir cap and surrounding area.
- Remove the reservoir cap and verify the coolant is within the normal range, approximately half full.
- If coolant is required, add 50/50 glycol coolant until the coolant is visible within the normal range.
- Reinstall the reservoir cap.
- Reinstall the access panel. Secure using the thumb screws.



Air Filter Maintenance



WARNING

Ensure XTV is parked on a flat level surface, transmission in the “N” Neutral position with parking brake engaged and wheels chocked.

- Remove the four (4) thumb screws securing the Engine Mid Access Panel and remove the panel.



WARNING

To prevent personal injury, use CAUTION as surfaces may be hot and may cause serious injury.



NOTE: If this area is RED, air filter replacement is necessary.

- Depress the latch on the airbox and rotate counter-clockwise to remove the air filter cover.
- Remove primary and secondary air filters and replace as necessary.



CAUTION

Ensure all dust or debris is removed from the airbox to prevent possible damage to the engine.

- Reinstall primary and secondary air filters.
- Reinstall air filter cover.
- Reset air filter service gauge by depressing the relief valve.
- Reinstall the Engine Mid Access Panel and secure using thumb screws.

Brake Fluid Maintenance

Remove the front (drivers side) floorboard by rotating the three (3) quarter-turn fasteners.

- Clean any debris from the brake master cylinder cap and surrounding area.
- Remove the cap.
- Ensure the brake fluid level is within 1/2" from the top of the master cylinder reservoir.
- If necessary, add appropriate amount and type of brake fluid per specifications.
- Reinstall cap. Tighten securely.
- Reinstall floorboard and rotate fasteners.



Windshield Washer Fluid Maintenance

Remove the front (passenger side) floorboard by rotating the three (3) quarter-turn fasteners.

- Clean any debris from the washer fluid cap and surrounding area.
- Ensure the windshield washer fluid level is near full.
- If necessary, remove cap and add additional washer fluid.
- Reinstall cap. Tighten securely.
- Reinstall floorboard and rotate fasteners.



Wheels and Tires - General Provisions

Mounting tires on the drive wheel can be performed by a qualified installer in compliance with generally accepted mounting safety regulations. Only serviceable, clean and dry tires and rims can be mounted.

Before installation, tires stored at temperatures below 32°F (0°C) shall be kept at temperatures above 32°F (0°C) for 3-5 hours.

Before mounting, tires shall be inspected outside and inside. Any foreign object in the tire must be removed.

The following tires may NOT be mounted and operated:

- with stretched (distorted) beads, beadlock fracture or destruction
- with tread separation
- cracking, checking
- under prolonged impact of petroleum products (oil, gasoline, kerosene, petroleum), or other substances that cause rubber swelling
- with through-tire damages
- with blisters on the sealing layer
- with cords and rubber layering
- with translucence of yarn through the rubber

Through damages must be repaired with the help of tubeless tire repair kit in compliance with instruction attached.

- 1 - tire
- 2 - tire tread
- 3 - outside wheel cone
- 4 - tire bead
- 5 - beadlock
- 6 - bolt

Do not install wheels with deformations, cracks, burrs and rust on the wheel parts contacting with tire, as well as cracked welding joints in wheel cones.

Wheel surfaces contacting with tire must be cleaned of rust and painted with lacquer for metal.

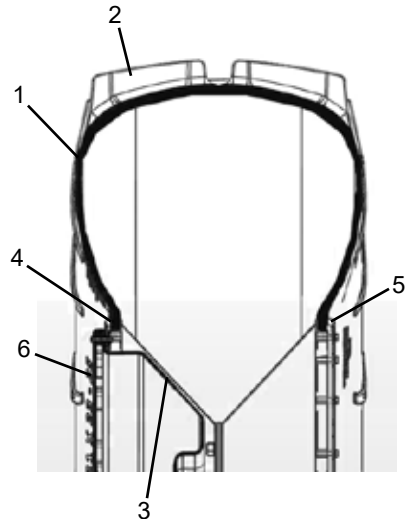

Dismounting Wheel Assembly

- Raise vehicle using suitable lift so desired tire is off the ground.
- Deflate tires
- Remove contents from wheel canister (if installed).
- Remove wheel canister (if installed).
- Remove wheel lug nuts.
- Remove wheel/tire assembly from drive hub. (Assistance may be required).

NOTE: Account for large O-ring that seals rim to the hub.

Mounting Wheel Assembly

- Clean hub surface with a clean cloth.
- Remove wheel hub O-ring, clean and reapply grease.
- Clean wheel hub O-ring groove and reapply grease to groove.
- Reinstall O-ring into groove.
- Install wheel/tire assembly onto XTV drive hub and tighten wheel nuts to 207 ft·lb. (280 N·m). For uniform tightening, nuts must be tightened in a criss-cross pattern.
- Reinstall wheel canister.
- Remove lift.

Tire Repair

NOTE: Depending on the size and type of the damage, tire repair can be performed without dismounting or removing the tire from the wheel or removing the wheel/tire assembly from the chassis.

With Wheel assembly removed from vehicle:

- Remove **INNER** beadlock from wheel.
- Place wheel/tire assembly (inner side facing up) on a clean platform or floor surface.
- If necessary to remove the rim, lift rim out of the tire using tire irons as needed.
- Repair tire as necessary.
- With rim/tire assembly on clean platform or floor surface, insert rim fully inside the tire (with rim tilted), first with one bead seat, then the other. (Use tire irons if necessary).
- Using a suitable scraper, remove any dried sealant residue from the inner rim/tire mating surface.
- Thoroughly degrease mating surface.
- Using suggested sealant (Loctite 939, or comparable sealant), apply a continuous 1/4" x 1/4" bead of sealant around the perimeter of the rim sealing surface.
- Reinstall **INNER** beadlock. Gradually tighten bolts in a criss-cross pattern. Torque bolts to 18.5 - 22.1 ft lb (30 - 35 Nm). After bolts are tightened, there should be no gap between beadlock and rim.
- Repeat torque sequence until specified torque is obtained.
- Stand wheel assembly in a vertical position.
- See "Mounting Wheel Assembly"

Tire Maintenance

Before driving the XTV it is necessary to:

- Check internal tire pressure and, if necessary, start the engine to bring the pressure to optimal driving pressure.
- Carefully inspect tires and rims. Remove any foreign objects (stones, nails, etc.).
- It is recommended to have tire repairs performed by an authorized ARGO dealer.
- Ensure all bolts attaching the beadlocks are present and ensure they are properly torqued. In case individual bolts are absent, replace as necessary.
- Check the wheel attachment to the hubs and, if necessary, tighten the lugnuts.

Wheel Lugnut Maintenance

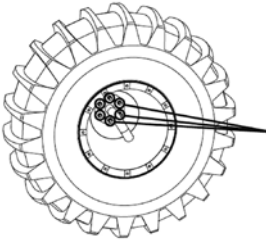

Check the torque of the wheel bolts after 50 hours of operation.

Check the torque of the wheel bolts after each wheel removal - installation, then after 50 hours of operation. Tighten wheel nuts to 207 ft·lb. (280 Nm). For uniform tightening, nuts must be tightened in a criss-cross pattern.

XTV Towing

Before towing XTV, ensure shift lever is in “N” neutral mode. XTV can be towed by using a rigid tow bar.



WARNING

Do not tow vehicle with tires deflated below 1 psi (52 mmHg). Damage to the wheel and/or tire may occur.

Securing the XTV for Transportation

Securing the vehicle for transportation is your responsibility.

Follow all local, state, and federal rules and regulations.

Follow the below procedures:

- Position shift lever in “D” drive gear.
- Engage parking brake.
- Secure vehicle to transport platform (such as trailer deck). It is recommended to use at least one strap positioned over each of the four axles.

NOTE: Tire pressures may fluctuate affecting strap tensions.

XTV Storage

CLEANING THE VEHICLE

Wash the vehicle body with a suitable outer body automotive detergent and rinse with water. Flush dirt out of the lower body by using a high pressure sprayer or garden hose after removing the drain plugs. Ensure the hold drain is dry and plugs are replaced.

STORING THE VEHICLE

When the vehicle is stored for an extended period, the following preparation is required:

Clean the Vehicle

Remove all dirt and water from the vehicle body as directed above.

Remove the hold drain plugs if the vehicle is not fully sheltered from the elements.



CAUTION

Any water accumulation in the vehicle will, over time, cause corrosion which may cause premature failure.

NOTE:

Bearing corrosion due to inadequate preparation and lubrication for storage is the leading cause of premature bearing failure.

Prepare the 12V Starting Batteries for Storage

Ensure the 12V batteries are fully charged with the battery disconnect switch in the OFF position. Clean and charge the batteries if necessary using an appropriate 12V battery charger. Coat the battery terminals with a multi-purpose grease to prevent corrosion.

Prepare the 16V (54V System) Batteries for Storage

Ensure the 16V batteries are fully charged with the battery disconnect switch in the OFF position. Clean and charge the batteries if necessary using an appropriate 16V battery charger. Coat the battery terminals with a multi-purpose grease to prevent corrosion.



WARNING

Do not store the battery near flames, sparks or any source of fire. Batteries can explode if exposed to flames or sparks, causing serious personal injury.

Recharge the battery monthly.

Protect the Electrical System

Spray the wiring harnesses and all the electrical connections with a silicone based lubricant (WD40 or equivalent) to prevent corrosion.

Carefully inspect the wiring for loose connections, bare wires or corrosion. Repair as necessary.

Raise the Vehicle

Place blocks under the front and rear chassis/hull of the vehicle to raise the tires off the ground.

Preparing the Engine for Storage

Read the engine operator's manual and carry out all recommended storage procedures.

SECTION 6



WARNING

IMMEDIATELY STOP OPERATION IF A FAULT IS DISPLAYED. CONTACT YOUR ARGO DEALER FOR MORE INFORMATION OR POSSIBLE SERVICE.

Fault Codes - Steering Controller DTCs

FAULT	DESCRIPTION	POSSIBLE CAUSES	RESET PROCEDURE
Controller Overcurrent	The steering motor controller output demand has exceeded its current limit. When this code is active the controller will shut down to prevent damage to the controller or steer motor.	Short circuit of the motor connections, motor speed encoder signal errors or a defective controller.	Turn the vehicle ignition off, allow the system to power down for 60 seconds.
Current Sensor	The steering motor controller current sensors have invalid offset readings. When this code is active the controller will shut down to prevent damage to the controller or steer motor.	Current/Voltage is shorted from the motor/motor connections to the chassis or a defective controller.	Turn the vehicle ignition off, allow the system to power down for 60 seconds.
PreCharge Failed	The steering motor controller capacitor failed to charge during initial power cycle. When this code is active the controller will shut down to prevent damage to the controller or steer motor.	An external load on the capacitor bank (B+ connection terminal).	Turn the vehicle ignition off, allow the system to power down for 60 seconds.
Controller Severe Undertemperature	The steering motor controller temperature is less than the allowable temperature of -40 F (-40 C). When this code is active the controller will shut down to prevent damage to the controller or steer motor.	The steering motor controller temperature must be above -40 F (-40 C) before it will power up.	Turn the vehicle ignition off, allow the system to power down for 60 seconds.

Fault Codes - Steering Controller DTCs

FAULT	DESCRIPTION	POSSIBLE CAUSES	RESET PROCEDURE
Controller Severe Overtemperature	The steering motor controller temperature has exceed the allowable temperature of 203 F (95 C). When this code is active the controller will shut down to prevent damage to the controller or steer motor.	The steering motor controller temperature must be below 203 F (95 C) before it will power up. Clean any debris/dirt that may be affecting the controllers ability to cool.	Turn the vehicle ignition off, allow the system to power down for 60 seconds.
Severe B+ Undervoltage	The battery supply voltage to the steering motor controller is below the allowable voltage of 26V DC. When this code is active the controller will shut down to prevent damage to the controller or steer motor.	The batteries may have an external drain, loose or disconnected cable, or damaged fuse to cause a low supply voltage.	Turn the vehicle ignition off, allow the system to power down for 60 seconds.
Severe B+ Overvoltage	The battery supply voltage to the steering motor controller is above the allowable voltage of 64V DC. When this code is active the controller will shut down to prevent damage to the controller or steer motor.	Incorrect battery output voltage in battery bank.	Turn the vehicle ignition off, allow the system to power down for 60 seconds.
Speed Limit Supervision	The steering motor speed exceeds the maximum speed limit. When this code is active the controller will shut down to prevent damage to the controller or steer motor.	Faulty motor encode or internal transmission causing overspeed condition.	Turn the vehicle ignition off, allow the system to power down for 60 seconds.

Fault Codes - Steering Controller DTCs

FAULT	DESCRIPTION	POSSIBLE CAUSES	RESET PROCEDURE
Motor Not Stopped	The steering motor controller has detected the steering motor is still in motion when commanded to stop. When this code is active the controller will shut down to prevent damage to the controller or steer motor.	Internal error in steering motor controller. The steering motor controller must be replaced.	Turn the vehicle ignition off, allow the system to power down for 60 seconds.
Critical OS General	The steering motor controller has an internal fault. When this code is active the controller will shut down to prevent damage to the controller or steer motor.	Internal error in steering motor controller. The steering motor controller must be replaced.	Turn the vehicle ignition off, allow the system to power down for 60 seconds.
OS General 2	The steering motor controller has an internal fault. When this code is active the controller will shut down to prevent damage to the controller or steer motor.	Internal error in steering motor controller. The steering motor controller must be replaced.	Turn the vehicle ignition off, allow the system to power down for 60 seconds.
Reset Rejected	The steering motor controller is attempting to reset while still controlling the steering motor. When this code is active the controller will shut down to prevent damage to the controller or steer motor.	The system power was turned off while operating the steering motor.	Turn the vehicle ignition off, allow the system to power down for 60 seconds.
Motor Short	The steering motor controller has detected a short circuit between 2 or more of the steering motor poles. When this code is active the controller will shut down to prevent damage to the controller or steer motor.	There is a short circuit in the wiring or motor internal components between the W, V or U poles of the motor.	Turn the vehicle ignition off, allow the system to power down for 60 seconds.

Fault Codes - Steering Controller DTCs

FAULT	DESCRIPTION	POSSIBLE CAUSES	RESET PROCEDURE
Controller Overtemperature Cutback	The steering motor controller temperature has exceed the temperature of 185 F (85 C). When this code is active the controller will reduce output to prevent damage to the controller or steer motor.	The steering motor controller temperature must be below 185 F (85 C) before it will power up. Clean any debris/dirt that may be affecting the controllers ability to cool.	Turn the vehicle ignition off, allow the system to power down for 60 seconds.
Undervoltage Cutback	The battery supply voltage to the steering motor controller is below the voltage of 26V DC. When this code is active the controller will reduce output to prevent damage to the controller or steer motor.	The batteries may have an external drain, loose or disconnected cable, or damaged fuse to cause a low supply voltage.	Turn the vehicle ignition off, allow the system to power down for 60 seconds.
Overvoltage Cutback	The battery supply voltage to the steering motor controller is above the voltage of 64 V DC. When this code is active the controller will reduce output to prevent damage to the controller or steer motor.	Incorrect battery output voltage in battery bank.	Turn the vehicle ignition off, allow the system to power down for 60 seconds.
Ext 5V Supply Failure	The 5 volt supply wire to the steering motor controller is not within the 5V +/- 10% parameter. When this code is active the 5V supply voltage is disabled.	Internal failure within Steering Motor Controller.	Turn the vehicle ignition off, allow the system to power down for 60 seconds.
Ext 12V Supply Failure	The 12 volt supply wire to the steering motor controller is not within the 12V +/- 15% parameter. When this code is active the 12V supply voltage is disabled.	Internal failure within Steering Motor Controller.	Turn the vehicle ignition off, allow the system to power down for 60 seconds.

Fault Codes - Steering Controller DTCs

FAULT	DESCRIPTION	POSSIBLE CAUSES	RESET PROCEDURE
Motor Temp Hot Cutback	The steering motor temperature has exceed the allowable temperature of 284 F (140 C). When this code is active the controller will reduce power to prevent damage to the controller or steer motor.	The steering motor temperature must be below 248 F (120 C) for normal operation. Clean any debris/dirt that may be affecting the controllers ability to cool.	Turn the vehicle ignition off, allow the system to power down for 60 seconds.
Motor Temp Sensor	The steering motor temperature sensor circuit is not within specifications.	Check that the steering motor temperature sensor is properly connected, the resistance of the sensor is within specification and that the polarity of the sensor is wired correctly.	Turn the vehicle ignition off, allow the system to power down for 60 seconds.
Main Driver	The Main driver circuit in the steering motor controller has detected an over/ under current draw. When this code is active the controller will shut down to prevent damage to the controller or steer motor.	Open or short on the driver load, dirty connector pins at controller, loose wiring connections or damaged wiring.	Turn the vehicle ignition off, allow the system to power down for 60 seconds.
EM Brake Driver	The EM Brake driver circuit in the steering motor controller has detected an over/ under current draw. When this code is active the controller will shut down to prevent damage to the controller or steer motor.	Open or short on the driver load, dirty connector pins at controller, loose wiring connections or damaged wiring.	Turn the vehicle ignition off, allow the system to power down for 60 seconds.

Fault Codes - Steering Controller DTCs

FAULT	DESCRIPTION	POSSIBLE CAUSES	RESET PROCEDURE
Pump Driver	The Pump driver circuit in the steering motor controller has detected an over/ under current draw. When this code is active the controller will shut down to prevent damage to the controller or steer motor.	Open or short on the driver load, dirty connector pins at controller, loose wiring connections or damaged wiring.	Turn the vehicle ignition off, allow the system to power down for 60 seconds.
Load Hold Driver	The Load Local driver circuit in the steering motor controller has detected an over/ under current draw. When this code is active the controller will shut down to prevent damage to the controller or steer motor.	Open or short on the driver load, dirty connector pins at controller, loose wiring connections or damaged wiring.	Turn the vehicle ignition off, allow the system to power down for 60 seconds.
Lower Driver	The Lower driver circuit in the steering motor controller has detected an over/ under current draw. When this code is active the controller will shut down to prevent damage to the controller or steer motor.	Open or short on the driver load, dirty connector pins at controller, loose wiring connections or damaged wiring.	Turn the vehicle ignition off, allow the system to power down for 60 seconds.
IM Motor Feedback	The steering motor controller detected a rapid decrease in steering motor RPM to zero RPM. When this code is active the controller will shut down to prevent damage to the controller or steer motor.	Open or short circuit in the motor encoder wiring or a possible motor encoder failure.	Turn the vehicle ignition off, allow the system to power down for 60 seconds.

Fault Codes - Steering Controller DTCs

FAULT	DESCRIPTION	POSSIBLE CAUSES	RESET PROCEDURE
Motor Open	The steering motor controller has detected an open circuit in one of the motor phase wires from the controller to the steering motor. When this code is active the controller will shut down to prevent damage to the controller or steer motor.	Loose connection of the motor phase wires from the controller to the steering motor or an internal open circuit in the steering motor.	Turn the vehicle ignition off, allow the system to power down for 60 seconds.
Main Contactor Welded	The steering motor controller has detected a load in the system prior to the main contactor closing to indicate the contactor is welded closed. When this code is active the controller will shut down to prevent damage to the controller or steer motor.	The steering motor phase U or V wires are disconnected or open, a short circuit from the battery + to the capacitor bank or the internal main contactor is welded closed.	Turn the vehicle ignition off, allow the system to power down for 60 seconds.
Main Contactor Did Not Close	The steering motor controller has detected the main contactor did not close when commanded, disconnected during operation or disconnected from battery. When this code is active the controller will shut down to prevent damage to the controller or steer motor.	Damaged fuse on battery + circuit, poor connection at the battery + cables, weak battery or internal controller fault.	Turn the vehicle ignition off, allow the system to power down for 60 seconds.

Fault Codes - Steering Controller DTCs

FAULT	DESCRIPTION	POSSIBLE CAUSES	RESET PROCEDURE
Motor Setup Needed	The steering motor controller setup has not been completed. When this code is active the controller will shut down to prevent damage to the controller or steer motor.	Internal programming is required, the controller must be replaced.	Turn the vehicle ignition off, allow the system to power down for 60 seconds.
Throttle Input	The steering motor controller has detected the throttle input voltage is outside the allowable parameters. When this code is active the controller will shut down to prevent damage to the controller or steer motor.	Open circuit or short to power on the throttle input wire or a faulty throttle sensor.	Turn the vehicle ignition off, allow the system to power down for 60 seconds.
Brake Input	The steering motor controller has detected the brake input voltage is outside the allowable parameters. When this code is active the controller will shut down to prevent damage to the controller or steer motor.	Internal short or malfunction, the controller must be replaced.	Turn the vehicle ignition off, allow the system to power down for 60 seconds.
NV Memory Failure	The steering motor controller failed to read or write to the EEPROM memory. When this code is active the controller will shut down to prevent damage to the controller or steer motor.	This is an internal memory fault, if the code remains active and cannot be reset, the controller must be replaced.	Turn the vehicle ignition off, allow the system to power down for 60 seconds.

Fault Codes - Steering Controller DTCs

FAULT	DESCRIPTION	POSSIBLE CAUSES	RESET PROCEDURE
HPD Sequencing	The steering motor controller detected an incorrect sequence of receiving signals from the keyswitch, interlock, direction or throttle. When this code is active the controller will shut down to prevent damage to the controller or steer motor.	Faulty wiring or component in inputs to the steering controller of the keyswitch, interlock, direction or throttle circuits.	Turn the vehicle ignition off, allow the system to power down for 60 seconds.
Parameter Change	The steering motor controller detected a safety related parameter was changed while the interlock was On. When this code is active the controller will shut down to prevent damage to the controller or steer motor.	Internal programming is required, the controller must be replaced.	Turn the vehicle ignition off, allow the system to power down for 60 seconds.
EMR Switch Redundancy	Internal parameters have been changed from factory settings.	Internal programming is required, the controller must be replaced.	Turn the vehicle ignition off, allow the system to power down for 60 seconds.
Steering Sensor Fault	The steering motor controller has detected the redundant steering angle values are not within specification. When this code is active the controller will shut down to prevent damage to the controller or steer motor.	Open or short circuit within the steering angle sensor causing the redundant signals to not match.	Turn the vehicle ignition off, allow the system to power down for 60 seconds.

Fault Codes - Steering Controller DTCs

FAULT	DESCRIPTION	POSSIBLE CAUSES	RESET PROCEDURE
Steering Sensor NO CAN	The steering motor controller has not received a message from the steering angle sensor in over 100ms. When this code is active the controller will shut down to prevent damage to the controller or steer motor.	Open or short circuit in the steering angle sensor circuit or sensor.	Turn the vehicle ignition off, allow the system to power down for 60 seconds.
Steering Not Centered on Startup	The steering motor controller detected the steering angle was not at 0 degrees during power up. When this code is active the controller will shut down to prevent damage to the controller or steer motor.	If the steering wheel was not rotated at the time of power up it is possible the steering angle sensor is defective	Turn the vehicle ignition off, allow the system to power down for 60 seconds.
VCL Run Time Error	The steering motor controller has detected an internal error in the VCL Module. When this code is active the controller will shut down to prevent damage to the controller or steer motor.	Reset the steering controller module, if the code does not clear the module must be replaced.	Turn the vehicle ignition off, allow the system to power down for 60 seconds.
OS General	The steering motor controller has detected an internal controller fault. When this code is active, the controller will shut down to prevent damage to the controller or steer motor.	Reset the steering controller module, if the code does not clear the module must be replaced.	Turn the vehicle ignition off, allow the system to power down for 60 seconds.

Fault Codes - Steering Controller DTCs

FAULT	DESCRIPTION	POSSIBLE CAUSES	RESET PROCEDURE
PDO Timeout	The steering motor controller has not received expected CAN messages from the chassis controller or steering sensor. When this code is active the controller will shut down to prevent damage to the controller or steer motor.	Chassis controller, steering sensor or wiring between the components not allowing CAN messages to be sent or received.	Turn the vehicle ignition off, allow the system to power down for 60 seconds.
Stall Detected	The steering motor controller has not detected any movement of the steering motor indicating it has stalled. When this code is active, the controller will shut down to prevent damage to the controller or steer motor.	Faulty motor encoder, loose connections between the motor and controller or a faulty steering motor.	Turn the vehicle ignition off, allow the system to power down for 60 seconds.
Supervision	The steering motor controller has detected an internal error. When this code is active the controller will shut down to prevent damage to the controller or steer motor.	Reset the steering controller module, if the code does not clear the module must be replaced.	Turn the vehicle ignition off, allow the system to power down for 60 seconds.
Supervision Input Check	The steering motor controller has detected an internal error. When this code is active the controller will shut down to prevent damage to the controller or steer motor.	Reset the steering controller module, if the code does not clear the module must be replaced.	Turn the vehicle ignition off, allow the system to power down for 60 seconds.

Fault Codes - Steering Controller DTCs

FAULT	DESCRIPTION	POSSIBLE CAUSES	RESET PROCEDURE
PDO Mapping Error	The steering motor controller has detected an internal error. When this code is active the controller will shut down to prevent damage to the controller or steer motor.	Reset the steering controller module, if the code does not clear the module must be replaced.	Turn the vehicle ignition off, allow the system to power down for 60 seconds.
Internal Hardware	The steering motor controller has detected an internal error. When this code is active the controller will shut down to prevent damage to the controller or steer motor.	Reset the steering controller module, if the code does not clear the module must be replaced.	Turn the vehicle ignition off, allow the system to power down for 60 seconds.
Motor Braking Impaired	The steering motor controller has detected an error in the steering motor. When this code is active the controller will shut down to prevent damage to the controller or steer motor.	Battery overcharged, motor or controller temperatures exceeds limits.	Turn the vehicle ignition off, allow the system to power down for 60 seconds.
Motor Characterization	Internal parameters have been changed from factory settings.	Internal programming is required, the controller must be replaced.	Turn the vehicle ignition off, allow the system to power down for 60 seconds.
Encoder Pulse Error	The steering motor controller has detected an error in the encoder pulse signal. When this code is active the controller will shut down to prevent damage to the controller or steer motor.	Intermittent short circuit or open in the encoder wiring, connections or encoder sensor or encoder wheel damage.	Turn the vehicle ignition off, allow the system to power down for 60 seconds.
Parameter Out of Range	Internal parameters have been changed from factory settings.	Internal programming is required, the controller must be replaced.	Turn the vehicle ignition off, allow the system to power down for 60 seconds.

Fault Codes - Fan Controller DTCs

FAULT	DESCRIPTION	POSSIBLE CAUSES	RESET PROCEDURE
Controller Over Voltage	The fan controller supply voltage has exceeded the limit of 90 VDC. When this code is active, the fan controller will shut down to prevent damage to the fan controller or fan motor.	Loose 54 volt battery cable connections, faulty 16 volt battery or faulty 54 volt regulator.	Turn the vehicle ignition off, allow the system to power down for 60 seconds.
Phase Over Current	Internal fan motor fault. When this code is active, the fan controller will shut down to prevent damage to the fan controller or fan motor.	Internal fan motor fault, fan motor must be replaced.	Turn the vehicle ignition off, allow the system to power down for 60 seconds.
Controller Over Temperature	When the fan controller temperature reaches 176 F (80 C), the controller will derate the output to prevent damage. Once the fan controller internal temperature has exceeded 212 F (100 C), the fan controller will shut down to prevent damage to the fan controller or fan motor.	Cooling fan not working properly or a faulty controller.	Turn the vehicle ignition off, allow the system to power down for 60 seconds.
Motor Hall Sensor Fault	Internal fan motor fault. When this code is active, the fan controller will shut down to prevent damage to the fan controller or fan motor.	Internal fan motor fault, fan motor must be replaced.	Turn the vehicle ignition off, allow the system to power down for 60 seconds.

Fault Codes - Fan Controller DTCs

FAULT	DESCRIPTION	POSSIBLE CAUSES	RESET PROCEDURE
Controller Under Voltage	The fan controller supply voltage is under the required minimum of 13.5 VDC. When this code is active, the fan controller will shut down to prevent damage to the fan controller or fan motor.	Loose 54 volt battery cable connections, faulty 16 volt battery or faulty 54 volt regulator/alternator.	Turn the vehicle ignition off, allow the system to power down for 60 seconds.
Post Static Gating Test	Internal fan motor fault. When this code is active, the fan controller will shut down to prevent damage to the fan controller or fan motor.	Internal fan motor fault, fan motor must be replaced.	Turn the vehicle ignition off, allow the system to power down for 60 seconds.
Instantaneous Phase Over Current	Internal fan motor fault. When this code is active, the fan controller will shut down to prevent damage to the fan controller or fan motor.	Internal fan motor fault, fan motor must be replaced.	Turn the vehicle ignition off, allow the system to power down for 60 seconds.
Motor Over Temperature	When the fan controller temperature reaches 176 F (80 C), the controller will derate the output to prevent damage. Once the fan controller internal temperature has exceeded 212 F (100 C), the fan controller will shut down to prevent damage to the fan controller or fan motor.	Cooling fan not working properly, plugged radiator or a faulty fan.	Turn the vehicle ignition off, allow the system to power down for 60 seconds.

Fault Codes - Fan Controller DTCs

FAULT	DESCRIPTION	POSSIBLE CAUSES	RESET PROCEDURE
Instantaneous Controller Over Voltage	The fan controller supply voltage has exceeded the limit of 90 VDC. When this code is active, the fan controller will shut down to prevent damage to the fan controller or fan motor.	Loose 54 volt battery cable connections, faulty 16 volt battery or faulty 54 volt regulator.	Turn the vehicle ignition off, allow the system to power down for 60 seconds.
Internal Error	Internal fan controller fault. When this code is active, the fan controller will shut down to prevent damage to the fan controller or fan motor.	Internal fan controller fault, fan controller must be replaced.	Turn the vehicle ignition off, allow the system to power down for 60 seconds.
Post Dynamic Gating Test	Internal fan motor fault. When this code is active, the fan controller will shut down to prevent damage to the fan controller or fan motor.	Internal fan motor fault, fan motor must be replaced.	Turn the vehicle ignition off, allow the system to power down for 60 seconds.
Instantaneous Under Voltage	The fan controller supply voltages below the minimum of 13.5 VDC. When this code is active, the fan controller will shut down to prevent damage to the fan controller or fan motor.	Loose 54 volt battery cable connections, faulty 16 volt battery or faulty 54 volt regulator/alternator.	Turn the vehicle ignition off, allow the system to power down for 60 seconds.
CAN Bus	The fan motor controller has detected an error in receiving CAN messages. When this code is active, the fan controller will shut down to prevent damage to the fan controller or fan motor.	CAN communication wires in harness may be open or shorted, damaged terminating resistor, chassis controller failure, fan controller failure.	Turn the vehicle ignition off, allow the system to power down for 60 seconds.

Fault Codes - Fan Controller DTCs

FAULT	DESCRIPTION	POSSIBLE CAUSES	RESET PROCEDURE
Hall Stall	Internal fan motor fault. When this code is active, the fan controller will shut down to prevent damage to the fan controller or fan motor.	Internal fan motor fault, fan motor must be replaced.	Turn the vehicle ignition off, allow the system to power down for 60 seconds.
Remote CAN Fault	The fan motor controller has detected an error in receiving CAN messages. When this code is active, the fan controller will shut down to prevent damage to the fan controller or fan motor.	CAN communication wires in harness may be open or shorted, damaged terminating resistor, chassis controller failure, fan controller failure.	Turn the vehicle ignition off, allow the system to power down for 60 seconds.
Open Phase Fault	The fan motor controller has detected an internal open circuit in the fan motor. When this code is active, the fan controller will shut down to prevent damage to the fan controller or fan motor.	Loose power cables between the controller and fan motor or faulty fan motor.	Turn the vehicle ignition off, allow the system to power down for 60 seconds.

Fault Codes - Engine DTCs

CODE	DESCRIPTION	SPN	FMI
P0002	Maximum positive deviation of rail pressure exceeded	157	11
P0003	Fuel Metering unit plausibility error in idle mode	1076	4
P0004	Fuel Metering unit plausibility error in overrun mode	1076	3
P000F	Common rail pressure relief valve is open	5571	25
P0072	Environment Temperature Sensor Signal Low	171	4
P0073	Environment Temperature Sensor Signal High	171	3
P007C	Inlet air temperature sensor Low fault	172	4
P007D	Inlet air temperature sensor High fault	172	3
P0087	Fuel Leakage is detected based on fuel quantity balance	157	10
P009B	Common rail pressure relief valve reached maximum allowed opening count	5571	22
P009C	Common rail pressure relief valve Forced to open status (Pressure increase)	5571	23
P009D	Common rail pressure relief valve Forced to open status (Pressure shock)	5571	24
P009F	Averaged rail pressure is outside the expected tolerance range	5571	27
P00AC	Intake manifold temperature sensor Low fault	105	4
P00AD	Intake manifold temperature sensor High fault	105	3
P00BC	Intake manifold pressure low plausibility fault (Compressor out pressure too low)	132	1
P00BE	Sensitivity drift error low for Air mass flow sensor	132	21
P0100	Signal error of Air mass flow sensor	132	19
P0101	Battery voltage error of Air mass flow sensor	132	5
P0102	Signal range check low error for Air mass flow sensor	132	4
P0103	Signal range check high error for Air mass flow sensor	132	3
P0107	Intake Manifold Pressure Sensor Low Fault	102	4
P0108	Intake Manifold Pressure Sensor High Fault	102	3
P0117	Coolant Temperature Sensor Low Fault	110	4
P0118	Coolant Temperature Sensor High Fault	110	3
P011E	Coolant Temperature Plausibility Fault	110	10
P0121	Hand pedal position track1 sensor High fault	91	15
P0122	Accel pedal position track1 sensor Low fault	91	4
P0123	Accel pedal position track1 sensor High fault	91	3
P0124	Hand pedal position track1 sensor Low fault	91	17
P0182	Fuel Temperature Sensor Low Fault	174	4
P0183	Fuel Temperature Sensor High Fault	174	3

Fault Codes - Engine DTCs

CODE	DESCRIPTION	SPN	FMI
P018C	Fuel filter pressure low fault	1382	1
P018D	Fuel filter pressure high fault	1382	0
P018F	Common rail pressure relief valve reached maximum allowed open time	5571	28
P0192	Rail pressure sensor Low fault	5313	4
P0193	Rail pressure sensor High fault	5313	3
P0196	Oil combination (Level and temperature) sensor itself Oil temperature out of range error	175	11
P01C2	Fuel filter pressure sensor signal low fault	1382	4
P01C4	Fuel Filter Pressure low detection 1 - Warning	1382	7
P01C5	Fuel Filter Pressure low detection 2 - Torque reduction	1382	13
P01C6	Fuel filter pressure sensor signal high fault	1382	3
P0201	Injector Open circuit Fault (Cylinder #1)	651	5
P0202	Open load on the power stage for cylinder #2	652	5
P0203	Injector Open circuit Fault (Cylinder #3)	653	5
P0204	Injector Open circuit Fault (Cylinder #4)	654	5
P0215	Engine shut off request through hardware	970	22
P0218	Timeout Error of CAN-Receive-Frame TRF1 (Transmission oil temperature)	65272	19
P0219	Engine over speed detection fault	190	0
P0221	Hand pedal position track2 sensor High fault	29	15
P0222	Accel pedal position track2 sensor Low fault	29	4
P0223	Accel pedal position track2 sensor High fault	29	3
P0224	Hand pedal position track2 sensor Low fault	29	17
P0252	Rail pressure too low for injection	1076	20
P0254	Maximum negative rail pressure deviation with metering unit on lower limit is exceeded	1076	16
P025A	Fuel metering unit Open circuit fault	4082	5
P025B	Fuel metering unit Over temperature fault	4082	7
P025C	Fuel metering unit Short circuit to Ground fault	4082	4
P025D	Fuel metering unit Short circuit to Battery fault	4082	3
P028A	PWM FAN Output open circuit fault	975	5
P028D	PWM FAN Output short to ground circuit fault	975	4
P028E	PWM FAN Output short to battery circuit fault	975	3
P02E0	Throttle valve H-Bridge Driver Open Circuit Fault	5419	5
P02E2	Throttle valve H-Bridge Driver Short circuit to ground	5419	4

Fault Codes - Engine DTCs

CODE	DESCRIPTION	SPN	FMI
P02E3	Throttle valve H-Bridge Driver Short circuit to battery	5419	3
P02E4	Throttle valve Position Open jammed fault	51	0
P02E5	Throttle valve Position Closed jammed fault	51	1
P02E7	Throttle valve Close Position Learning Drift Fault	51	30
P02E8	Throttle valve Position Sensor Low Fault	51	4
P02E9	Throttle valve Position Sensor High Fault	51	3
P02EA	Throttle valve Close Position Learning Drift Fault for long time	51	22
P02EB	Throttle valve Close Position Learning Drift Fault for short time	51	23
P02EE	Injector Short circuit Fault (Cylinder #1)	651	4
P02EF	Injector Short circuit Fault (Cylinder #2)	652	4
P02F0	Injector Short circuit Fault (Cylinder #3)	653	4
P02F1	Injector Short circuit Fault (Cylinder #4)	654	4
P0340	Cam Signal Drift Fault	637	30
P0342	Cam Signal Lost fault	637	8
P0344	Cam Signal disturbed fault	637	2
P0372	Crank Signal disturbed fault	636	2
P0374	Crank No signal error	636	8
P0380	Glow plug Relay driver Open circuit Fault	676	5
P0381	Glow plug Lamp Open circuit	1081	5
P0383	Glow plug Relay driver Short circuit to Ground Fault	676	4
P0384	Glow plug Relay driver Short circuit to Battery Fault	676	3
P0406	EGR Position Sensor High Fault	27	3
P0407	EGR Position Sensor Low Fault	27	4
P0408	Maximum EGR rate governor deviation	3236	16
P0421	DOC Exothermal Efficiency Fault	173	1
P042E	EGR Position Open jammed fault	27	0
P042F	EGR Position Closed jammed fault	27	1
P049B	EGR rate slow response positive error	3236	0
P0512	Starter switch stuck fault (Cranking request is too long.)	626	12
P0522	Engine Oil Pressure Sensor Low Fault	100	4
P0523	Engine Oil Pressure Sensor High Fault	100	3
P0527	Fan speed signal long period fault path	1639	11
P0528	Fan speed too high fault	1639	3
P0529	Fan speed too low fault	1639	4
P0544	Turbine inlet temperature Plausibility Fault	2789	11

Fault Codes - Engine DTCs

CODE	DESCRIPTION	SPN	FMI
P0545	Turbine inlet temperature sensor Low fault	2789	4
P0546	Turbine inlet temperature sensor High fault	2789	3
P055B	Oil Pressure Warning Lamp Open circuit	5099	5
P055C	Short circuit to ground error of oil pressure lamp	5099	4
P055D	Oil Pressure Warning Lamp Short to Battery	5099	3
P0562	Battery Voltage Signal Range Min fault	444	4
P0563	Battery Voltage Signal Range Max fault	444	3
P056D	DEF Supply module PWM signal fault	7538	26
P0591	PTO (Idle up) Lamp Open circuit	5067	5
P0592	PTO (Idle up) Lamp Short to Ground	5067	4
P0593	PTO (Idle up) Lamp Short to Battery	5067	3
P05ED	DEF heater line circuit Short circuit to battery Fault	5746	6
P060B	ECU ADC(Analog to Digital Converter) NTP(Null Load Test Pulse) Monitoring fault	520618	12
P060C	ECU query response-communication error	520698	12
P0615	Starter relay power stage output open circuit	7748	5
P0616	Starter relay power stage output short circuit to ground	7748	4
P0617	Starter relay power stage output short circuit to battery	7748	3
P062D	Injector bank 1st Short circuit fault	1612	3
P062E	Injector bank 2nd Short circuit fault	1612	12
P062F	ECU EEPROM Read Error	55296	12
P0630	ECU EEPROM Write Error	55552	12
P0641	ECU Sensor Supply (5V) Overvoltage monitoring error	3509	11
P0642	ECU Sensor Supply (5V) Undervoltage monitoring error	3510	11
P0657	ECU Sensor Supply (5V)1 Short circuit to ground	3509	6
P0658	ECU Sensor Supply (5V)1 Under voltage fault	3509	4
P0659	ECU Sensor Supply (5V)1 Over voltage fault	3509	3
P0669	ECU temperature High fault	1027	0
P0685	ECU Main relay Stuck fault	1485	7
P068A	ECU Main relay Early opening fault	1485	11
P06AD	ECU temperature sensor Low fault (Short circuit to ground)	1207	4
P06AE	ECU temperature sensor High fault (Short circuit to battery)	1207	3
P06F0	DEF Supply module temperature duty cycle in failure range	7538	12
P06F1	Diagnostic Fault Check for DEF supply module duty cycle in the invalid range	7538	13

Fault Codes - Engine DTCs

CODE	DESCRIPTION	SPN	FMI
P0C17	EGR Close Position Learning Range Over Fault	27	20
P0C18	EGR Close Position Learning Drift Fault for long time	27	22
P0C19	EGR Close Position Learning Drift Fault for short time	27	23
P1013	MoF(Monitoring of Function) Engine speed error	520797	12
P101A	MoF(Monitoring of Function) Over Run error	520643	12
P1033	DPF(SDPF) inlet temperature High fault	3242	0
P1044	DEF Tank Temperature sensor Low plausibility fault	3031	18
P1045	DEF Tank Temperature sensor High plausibility fault	3031	16
P106C	DEF Quality Too Low fault	3516	1
P106D	DEF Quality Too High fault	3516	0
P1073	Environment Temperature Too High	171	0
P107D	Inlet air temperature High fault	172	0
P108A	DEF Supply Pump Motor Speed Deviation Fault	4374	8
P108B	DEF Supply Pump Motor Speed Deviation Permanent Fault	4374	9
P108C	DEF Supply Pump Motor No activation Fault	4374	12
P10AD	Intake manifold temperature High fault	105	16
P1118	Coolant high temperature Fault	110	0
P1183	Fuel temperature high fault	174	0
P1227	DEF Tank temperature plausibility fault (Insufficient temperature increment)	4365	14
P1230	DEF Tank Level Signal error	1761	19
P12E5	NCD inducement Fault Level1 (Group1 - EGR Block)	520723	12
P12E6	NCD inducement Fault Level2 (Group1 - EGR Block)	520724	12
P12E7	NCD inducement Fault Level3 Final inducement (Group1 - EGR Block)	520725	12
P12E8	NCD inducement Fault Warning (Group1 - EGR Block)	520726	12
P12E9	NCD inducement Fault Level1 (Group2 –Dosing Interrupt)	520727	12
P12EA	NCD inducement Fault Level2 (Group2 –Dosing Interrupt)	520728	12
P12EB	NCD inducement Fault Level3 Final inducement (Group2 – Dosing Interrupt)	520729	12
P12EC	NCD inducement Fault Warning (Group2 – Dosing Interrupt)	520730	12
P12F2	NCD inducement Fault Level1 (Group4 – DEF Quality)	520736	12
P12F3	NCD inducement Fault Level2 (Group4 – DEF Quality)	520737	12
P12F4	NCD inducement Fault Level3 Final inducement (Group 4 – DEF Quality)	520738	12
P12F5	NCD inducement Fault Warning (Group 4 – DEF Quality)	520739	12

Fault Codes - Engine DTCs

CODE	DESCRIPTION	SPN	FMI
P12F6	NCD inducement Fault Level1 (Group 5 – Tampering)	520740	12
P12F7	NCD inducement Fault Level2 (Group 5 – Tampering)	520741	12
P12F8	NCD inducement Fault Level3 Final inducement (Group 5 – Tampering)	520742	12
P12F9	NCD inducement Fault Warning (Group 5 – Tampering)	520743	12
P1303	NCD inducement Repeat offense Level 1	520790	12
P1304	NCD inducement Repeat offense Level 2	520791	12
P1305	NCD inducement Repeat offense Level 3 Final inducement	520792	12
P1450	DEF Overpressure error at METERING CONTROL (DEF pump pressure is too high)	4335	0
P1451	DEF Underpressure error at METERING CONTROL (DEF pump pressure is too low)	4335	1
P1452	DEF Overpressure error regardless of the state (DEF pump pressure is too high)	4335	12
P1453	DEF pressure stabilization error at DETECTION MODE (DEF pump pressure is not stable)	5435	10
P1454	DPF differential pressure too low fault	3251	18
P1457	DEF pressure build up error at PRESSURE BUILDUP (DEF pump pressure is too low)	4335	2
P1459	(Detected an insufficient pressure drop)	4335	15
P1460	DEF underpressure error at AFTERRUN_PRESSURE COMPENSATION	4335	16
P1461	DEF Reverting valve is blocked (Detected an insufficient pressure drop)	5436	14
P1522	Engine Oil Pressure Too Low Fault	100	1
P1546	Turbine inlet temperature High fault	2789	0
P1562	Battery Voltage Low fault (Warning)	444	1
P1563	Battery Voltage High fault (Warning)	444	0
P1564	Powerstage diagnosis disabled due to high Battery voltage	444	12
P1565	Powerstage diagnosis could be disabled due to low Battery voltage	444	2
P160B	CY327(Power control chipset) SPI (Serial Peripheral Interface Bus) Communication Error	520601	12
P160C	ECU ADC(Analog to Digital Converter) Test error	520696	12
P160D	ECU ADC(Analog to Digital Converter) Voltage ratio error	520697	12
P160E	ECU SPI (Serial Peripheral Interface Bus) communication error	520699	12
P160F	ECU ROM Memory multiple error	520641	12
P1610	ECU MM(Monitoring Module) Synchronization Loss fault during Shut-off path test	520642	12

Fault Codes - Engine DTCs

CODE	DESCRIPTION	SPN	FMI
P1611	ECU Shut-off path test error	520700	12
P1612	ECU Wrong set response time error during shut off path test	520701	12
P1613	ECU Too many SPI (Serial Peripheral Interface Bus) errors during shut off path test	520702	12
P1614	ECU Undervoltage error during Shut-off path test	520707	4
P1615	ECU WDA working error during Shut-off path test	520703	12
P1616	ECU OS Timeout error during Shut-off path test	520704	12
P1617	ECU Positive test failure error during Shut-off path test	520705	12
P1618	ECU Shut-off path test timeout fault	520706	12
P1619	ECU Overvoltage error during Shut-off path test	520707	3
P1657	ECU Sensor Supply (5V)1 voltage fault	3509	5
P1669	ECU Sensor Supply (5V)2 voltage fault	3510	5
P1684	ECU Sensor Supply (5V)3 voltage fault	3511	5
P1893	DEF backflow Line plausibility error at DETECTIONMODE (Does not detect a pressure drop)	4344	2
P1904	Glow plug Lamp Short to Ground	1081	4
P1906	DPF lamp 3 (DPF regeneration switch inhibit lamp) Open circuit	6916	5
P1907	DPF lamp 3 (DPF regeneration switch inhibit lamp) Short to Ground	6916	4
P1908	DPF lamp 3 (DPF regeneration switch inhibit lamp) Short to Battery	6916	3
P190B	Maximum rail pressure exceeded	157	27
P190C	Rail pressure too low fault	157	26
P192E	CE(Check engine) Lamp Open circuit	987	5
P192F	CE(Check engine) Lamp Short to Ground	987	4
P1931	CE(Check engine) Lamp Short to Battery	987	3
P1934	Pressure relief valve(PRV) failure	157	28
P202D	DEF Leakage detection at METERINGCONTROL	4335	7
P202E	DEF dosing valve actuator Over temperature Fault	3361	13
P2032	DPF(SDPF) inlet temperature sensor Low fault	3242	4
P2033	DPF(SDPF) inlet temperature sensor High fault	3242	3
P2034	DPF(SDPF) inlet temperature Plausibility Fault	3242	11
P2035	DPF(SDPF) inlet temperature Drift fault	3242	20
P203A	DEF Level Sensor Open circuit	3532	3
P203F	DEF Tank level is empty	3517	18
P2041	DEF Level Sensor Short circuit	3532	4

Fault Codes - Engine DTCs

CODE	DESCRIPTION	SPN	FMI
P2043	DEF Temperature Sensor Open circuit	4365	3
P2046	DEF Temperature Sensor Short circuit	4365	4
P2047	DEF dosing valve actuator Short circuit to battery Fault	3361	3
P2048	DEF dosing valve actuator Short circuit to ground Fault	3361	4
P2049	DEF dosing valve actuator Open Circuit Fault	3361	5
P204A	DEF pressure check error at DETECTIONMODE (Detected an insufficient pressure drop)	5435	12
P204C	DEF Supply Pump pressure sensor Low fault	6875	4
P204D	DEF Supply Pump pressure sensor High fault	6875	3
P2050	DEF dosing valve actuator HS(High side) Short circuit to battery Fault	3361	22
P2051	DEF dosing valve actuator HS(High side) Short circuit to ground Fault	3361	23
P205E	DEF Tank temperature overheated	3031	14
P208A	DEF Supply Pump Motor Signal Open circuit Fault	4374	5
P208B	DEF Supply Pump Motor Signal Over temperature Fault	4374	7
P208C	DEF Supply Pump Motor Signal Short circuit to ground Fault	4374	4
P208D	DEF Supply Pump Motor Signal Short circuit to battery Fault	4374	3
P208E	DEF Dosing valve is blocked	3361	27
P20A0	DEF Reverting valve output Open circuit Fault	5436	5
P20A1	DEF Reverting valve output Over temperature Fault	5436	7
P20A2	DEF Reverting valve output Short circuit to ground Fault	5436	4
P20A3	DEF Reverting valve output Short circuit to battery Fault	5436	3
P20A5	DEF Reverting valve Pressure drop plausibility fault	5436	11
P20AC	DEF Supply module heater temperature duty cycle in failure range	7538	22
P20AD	DEF Supply module heater temperature duty cycle in invalid range	7538	23
P20B0	DEF Supply module temperature measurement non-availability fault	7538	24
P20B1	DEF Tank heating coolant valve output Open circuit Fault	3363	5
P20B3	DEF Tank heating coolant valve output Short circuit to ground Fault	3363	4
P20B4	DEF Tank heating coolant valve output Short circuit to battery Fault	3363	3
P20B9	DEF Supply module heater relay output Open circuit Fault	7416	5
P20BA	DEF Supply module heater feedback plausibility Fault	7416	12
P20BB	DEF Supply module heater relay output Short circuit to ground Fault	7416	4

Fault Codes - Engine DTCs

CODE	DESCRIPTION	SPN	FMI
P20BC	DEF Supply module heater relay output Short circuit to battery Fault	7416	3
P20BD	DEF Pressure line heater relay output Open circuit Fault	5491	5
P20BE	DEF Pressure line heater feedback plausibility Fault	5491	12
P20BF	DEF Pressure line heater relay output Short circuit to ground Fault	5491	4
P20C0	DEF Pressure line heater relay output Short circuit to battery Fault	5491	3
P20C1	DEF Backflow line heater relay output Open circuit Fault	7069	5
P20C2	DEF Backflow line heater feedback plausibility Fault	7069	12
P20C3	DEF Backflow line heater relay output Short circuit to ground Fault	7069	4
P20C4	DEF Backflow line heater relay output Short circuit to battery Fault	7069	3
P20C5	DEF Suction line heater relay output Open circuit Fault	7540	5
P20C6	DEF Suction line heater feedback plausibility Fault	7540	12
P20C7	DEF Suction line heater relay output Short circuit to ground Fault	7540	4
P20C8	DEF Suction line heater relay output Short circuit to battery Fault	7540	3
P20EE	SCR Efficiency Too low fault	4364	14
P20FF	DEF Supply module time period outside specified range	7538	25
P2135	Accel pedal position sensor plausibility fault (Not synchronism between track1 and track2)	91	11
P2136	Hand pedal position sensor plausibility fault (Not synchronism between track1 and track2)	91	12
P213E	Injection cut off demand (ICO) for shut off coordinator	8614	12
P2143	EGR H-Bridge Driver Open Circuit Fault	2791	5
P2144	EGR H-Bridge Driver Short circuit to ground	2791	4
P2145	EGR H-Bridge Driver Short circuit to battery	2791	3
P214F	DEF Supply module heater circuit Open circuit Fault	5706	5
P215E	DEF Suction line heater circuit Open circuit or Short circuit to ground Fault	4356	6
P215F	DEF Suction line heater circuit Open circuit Fault	4356	5
P21C2	DEF Main heater relay output Open circuit Fault	5746	5
P21C3	DEF Main heater relay output Short circuit to ground Fault	5746	4
P21C4	DEF Main heater relay output Short circuit to battery Fault	5746	3
P21C7	SCR system Main relay open circuit	5965	5
P21C8	SCR system Main relay short circuit to ground	5965	4
P21C9	SCR system Main relay short circuit to battery	5965	3
P21DD	DEF Supply module heater circuit Open circuit or Short circuit to ground Fault	5706	6
P2202	NOx sensor Short circuit fault (Upstream NOx sensor)	3224	6

Fault Codes - Engine DTCs

CODE	DESCRIPTION	SPN	FMI
P2203	NOx sensor Open circuit fault (Upstream NOx sensor)	3224	5
P2215	NOx sensor Short circuit fault (Downstream NOx sensor)	3234	6
P2216	NOx sensor Open circuit fault (Downstream NOx sensor)	3234	5
P221C	DEF Pressure line heater circuit Open circuit or Short circuit to ground Fault	4354	6
P221D	DEF Pressure line heater circuit Open circuit Fault	4354	5
P221E	DEF Backflow line heater circuit Open circuit or Short circuit to ground Fault	4355	6
P221F	DEF Backflow line heater circuit Open circuit Fault	4355	5
P2228	Atmospheric Pressure Sensor Low Fault	108	4
P2229	Atmospheric Pressure Sensor High Fault	108	3
P225D	NOx sensor 1 (Upstream) concentration Low plausibility fault	3216	18
P2265	Water in fuel detected – Torque de-rate step (After 20min)	97	23
P2266	Water In Fuel Sensor signal range low fault	97	4
P2267	Water In Fuel Sensor signal range high fault	97	3
P2269	Water in fuel detected – Warning step	97	14
P2381	Glow plug Lamp Short to Battery	1081	3
P2383	NOx sensor Mounting Error (Upstream NOx sensor)	104332	9
P2384	NOx sensor Mounting Error (Downstream NOx sensor)	104385	9
P2397	NOx sensor signal low fault (Upstream NOx sensor)	3216	4
P2398	NOx sensor signal low fault (Downstream NOx sensor)	3226	4
P23B2	DEF Supply module heater plausibility fault (Insufficient temperature increment)	5706	22
P23B3	DEF Supply module heater temperature plausibility fault (Insufficient temperature increment)	5706	12
P23B4	DEF Supply module heater temperature plausibility fault at cold start (Insufficient temperature increment)	5706	14
P23B5	DEF Supply module temperature plausibility fault (Insufficient temperature increment)	7107	12
P23B6	DEF Supply module temperature plausibility fault at cold start (Insufficient temperature increment)	7107	14
P242F	DPF Ash loading High fault (Ash cleaning is needed)	3720	16
P244A	DPF differential pressure too low fault	3251	18
P2454	DPF differential pressure sensor Low fault	3251	4
P2455	DPF differential pressure sensor High fault	3251	3
P2463	DPF Soot mass high status (> 110%)	4781	16
P2465	DPF differential pressure high fault (Warning)	5629	15

Fault Codes - Engine DTCs

CODE	DESCRIPTION	SPN	FMI
P246B	DPF regeneration failure (DPF regeneration is not performed well during machine operation mode)	3715	14
P246C	DPF differential pressure too high fault	5629	14
P24A3	DPF Soot mass too high status (> 120%)	4781	15
P2505	ECU over temperature for SCR Monitoring	1867	1
P2506	ECU Software Reset 0 fault	1867	22
P2507	"ABE active" report due to undervoltage detection	1867	4
P2508	"ABE active" report due to overvoltage detection	1867	3
P2509	"WDA active" report due to errors in query- response communication	1867	19
P250A	Oil combination (Level and temperature) sensor itself open or short circuit error	98	5
P250C	Oil combination (Level and temperature) signal short circuit to ground error	98	4
P250D	Oil combination (Level and temperature) signal short circuit to battery error	98	3
P250F	Engine oil level is too low (Low step3)	98	18
P2511	"WDA/ABE active" report due to unknown reason	1867	11
P2546	Multi-torque switch signal too low fault	1568	4
P2547	Multi-torque switch signal too high fault	1568	3
P25BA	DPF regeneration inhibit & enable switch plausibility fault (Hardware)	3696	11
P25BB	DPF regeneration enable switch Stuck (Short to Battery) fault (Hardware)	3696	3
P25BC	DPF regeneration inhibit switch Stuck (Short to Battery) fault (Hardware)	3695	3
P260E	DPF lamp 1 (DPF regeneration switch enable lamp) Open circuit	3697	5
P260F	DPF lamp 1 (DPF regeneration switch enable lamp) Short to Ground	3697	4
P2611	DPF lamp 1 (DPF regeneration switch enable lamp) Short to Battery	3697	3
P2632	Electric fuel feed pump Output open circuit fault	6323	5
P2633	Electric fuel feed pump Output short to ground circuit fault	6323	4
P2634	Electric fuel feed pump Output short to battery circuit fault	6323	3
P2635	Electric fuel feed pump performance fault	6323	13
P263D	DEF pressure line heater error (Perform afterrun)	3360	14
P2669	ECU Sensor Supply (5V)2 Short circuit to ground	3510	6
P2670	ECU Sensor Supply (5V)2 Under voltage fault	3510	4

Fault Codes - Engine DTCs

CODE	DESCRIPTION	SPN	FMI
P2671	ECU Sensor Supply (5V)2 Over voltage fault	3510	3
P2684	ECU Sensor Supply (5V)3 Short circuit to ground	3511	6
P2685	ECU Sensor Supply (5V)3 Under voltage fault	3511	4
P2686	ECU Sensor Supply (5V)3 Over voltage fault	3511	3
P268C	Injector Code(IQA) Program Missing Fault (Cylinder#1)	651	2
P268D	Injector Code(IQA) Program Missing Fault (Cylinder#2)	652	2
P268E	Injector Code(IQA) Program Missing Fault (Cylinder#3)	653	2
P268F	Injector Code(IQA) Program Missing Fault (Cylinder#4)	654	2
P273F	Transmission oil temperature high fault (CAN)	177	15
P274F	Transmission oil temperature high fault (H/W Switch)	177	16
P2C11	DEF dosing valve plausibility fault	3361	14
P304C	DEF Supply Pump pressure sensor Low plausibility fault	6875	18
P304D	DEF Supply Pump pressure sensor High plausibility fault	6875	16
P3052	DPF differential pressure drift fault	3251	13
P30B1	DEF Tank heating coolant valve output Over temperature Fault	3363	7
P30B9	DEF Supply module heater relay output Over temperature Fault	7416	7
P30BD	DEF Pressure line heater relay output Over temperature Fault	5491	7
P30C1	DEF Backflow line heater relay output Over temperature Fault	7069	7
P30C5	DEF Suction line heater relay output Over temperature Fault	7540	7
P31C5	DEF Main heater relay output Over temperature Fault	5746	7
P32EE	Injector High Low side Short circuit Fault (Cylinder #1)	651	22
P32EF	Injector High Low side Short circuit Fault (Cylinder #2)	652	22
P32F0	Injector High Low side Short circuit Fault (Cylinder #3)	653	22
P32F1	Injector High Low side Short circuit Fault (Cylinder #4)	654	22
P350D	Oil combination (Level and temperature) sensor timeout fault	98	22
P350E	Oil combination (Level and temperature) sensor itself Voltage out of range error	98	23
P350F	Engine oil level is low (Low step2)	98	24
P360E	DPF lamp 2 (DPF Regeneration Active Lamp) Open circuit	6915	5
P360F	DPF lamp 2 (DPF Regeneration Active Lamp) Short to Ground	6915	4
P3611	DPF lamp 2 (DPF Regeneration Active Lamp) Short to Battery	6915	3
U0028	CAN bus off error	639	19
U0029	CAN communication error	639	2
U010F	Timeout Error of CAN-Receive-Frame DPM1 (Air Conditioning Switch Status / Oil life reset)	65401	19

Fault Codes - Engine DTCs

CODE	DESCRIPTION	SPN	FMI
U013C	Message Check Sum Error of CAN Receive Frame SMVCU (Pedal & Engine speed demand from VCU)	65400	22
U01B7	(Status of regeneration initiate and inhibit switches)	57344	19
U01B8	Timeout Error of CAN-Receive-Frame DPM9 (Multiple torque Map select switch)	65402	19
U01B9	Timeout Error of CAN-Receive-Frame EBC1 (Engine shut off request)	61441	19
U029D	Timeout Error of CAN-Receive-Frame AT11G1 (NOx Upstream Concentration)	61454	19
U029E	Timeout Error of CAN-Receive-Frame AT1O1 (NOx Downstream Concentration)	61455	19
U02A2	Timeout Error of CAN-Receive-Frame A1DEF1 (DEF Tank)	64923	19
U030D	NOx sensor heating error (Upstream NOx sensor)	3219	7
U030E	NOx sensor heating error (Downstream NOx sensor)	3229	7
U043D	Message Counter Error of CAN Receive Frame SMVCU (Pedal & Engine speed demand from VCU)	65400	23
U0606	Timeout Error of CAN-Receive-Frame EEC2 (Pedal)	91	19
U0607	Timeout Error of CAN-Receive-Frame TSC1VE (Engine speed & Torque demand)	0	19
U0608	RxSMVCU (Pedal & Engine speed demand from VCU)	65400	19
U0619	Timeout Error of CAN-Receive-Frame AT1T1I (DEF Level, Temperature over CAN)	65110	19
U0632	Timeout Error of CAN-Receive-Frame FanCtl (FAN Control)	65320	19
U1001	Timeout Error of CAN-Receive-Frame AAI (Hydraulic Oil Temperature)	65164	19
U1003	Engine shut off request through CAN (EBC1)	970	12
U1028	DEF Quality Sensor Open circuit	3520	3
U1030	DEF Quality Sensor Short circuit	3520	4
U1031	Timeout Error of CAN-Receive-Frame AUXIO1 (status of vehicle cut off [Safety bar])	65241	19
U1032	Timeout Error of CAN-Receive-Frame RxCCVS (PTO / Idle up)	65265	19
U1033	Timeout Error of CAN-Receive-Frame EOI (Engine Starter Motor Relay Control)	6385	19

SECTION 7

Ratings

XTV ratings include product identification numbers (PIN) and numbers of its component parts, the body and the engine.

- 1 - XTV PIN plate is located below the Battery Disconnect Switch on the drivers side of the vehicle.
- 2 - Product identification number (PIN) is engraved on the passenger side frame tube in the cab under the passenger side floorboard.

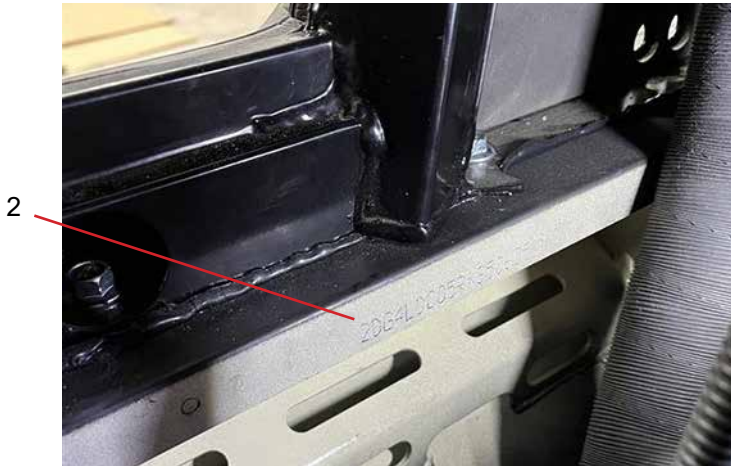



LIMITED WARRANTY

Ontario Drive & Gear Limited (hereinafter “ARGO”) extends a limited warranty on each new ARGOTV and on each genuine ARGOTV part and accessory sold by an authorized ARGOTV dealer. The limited warranty on an ARGOTV is provided to the original retail purchaser; however, the balance of the unused warranty may be transferred to another party through an ARGOTV dealer, but any such transfer will not extend the original term of the warranty. Warranty coverage is limited to the country in which the original retail purchase occurs and to the original retail purchaser resident in that country or, if transferred to a resident in that country for the balance of the remaining warranty.

The warranty is validated upon examination of said parts by ARGOTV or an authorized ARGOTV dealer. ARGOTV reserves the right to inspect such parts at its factory for final determination if warranty should apply. ARGOTV will repair or replace, at its option (including any related labor charges), any parts that are found to be warrantable in material or workmanship. This repair work must be done by an authorized ARGOTV dealer. No transportation charges, rental charges, or inconvenience costs will be paid by ARGOTV.

ARGOTV does not assume any liability for incidental or consequential damages.

WARRANTY COVERAGE PERIOD

1. Standard Warranty - 1 year or 1000 hours from the date of sale, whichever comes first.
2. Powertrain Warranty - 3 years or 3000 hours from date of sale, whichever comes first.
 - a. Includes coverage for defects in material or workmanship of the engine, transmission, and drivetrain.

Argo Promotional Extended Warranty provided at the time of sale will follow the Standard Warranty guidelines and coverage. Excludes batteries.

The warranty does not cover normal wear, abuse, or corrosion.

WARRANTY LIMITATIONS AND EXCLUSIONS

This ARGOTV limited warranty will become null and void if:

1. Failure to perform the proper break-in procedure and all related maintenance, storage procedures (if stored for extended periods), and/or service as recommended in the Operator’s Manual.
2. Repairs and/or adjustments made by anyone other than an authorized ARGOTV dealer unless instructed by ARGOTV.
3. Any modification, addition, or removal of parts unless instructed to do so by ARGOTV.
4. Removal of the engine for use in another vehicle.
5. Use of improper fuels, lubricating oils, or spark plug(s).
6. Vehicle has been involved in an accident or subject to misuse, abuse, or negligent operation, including overloading.
7. Use of the vehicle in any way for racing purposes.
8. Removal or mutilation of the Product Identification Number or Engine Serial Number.



9. Damage due to improper transportation.
10. Use of aftermarket or unapproved parts, accessories or attachments not sold by ARGO.
11. Damage caused by Acts of God, such as storm damage, hail, lightning, and other environmental conditions.
12. Collision, fire, theft, freezing, vandalism, riot, explosion, or objects striking the vehicle.
13. Tampering with the vehicle's hour meter.

In consideration of the foregoing, any implied warranty is limited in duration to the warranty periods set forth. This warranty gives you specific legal rights, and you may also have other rights which vary from state/province to state/province and country to country. Some jurisdictions do not allow limitations on how long an implied warranty lasts, so the above limitations may not apply to you.

WARRANTY PROCEDURE / OWNER RESPONSIBILITY

At the time of sale, a Training Certificate (if applicable) or an Owner Registration form is to be completed by the selling dealer and consumer. The receipt of the form by ARGO is a condition precedent to warranty coverage. It is the selling dealer's responsibility to retain and/or submit appropriate electronic registration to initiate warranty coverage.

The selling dealer is responsible to furnish the consumer a signed copy of the form which must be presented to the dealer when requesting warranty service. The registration form is the consumer's proof of ownership and warranty eligibility. The form is to be used by the dealer to validate the warranty claim. Retain your copy of the Owner Registration form and keep it in a safe place.

When warranty repair is suspected, the vehicle should be taken to an authorized ARGO dealer, who has the primary responsibility to perform warranty repairs.

The authorized ARGO dealer will examine the vehicle or part to determine if a warrantable condition exists. If a warrantable condition appears to exist, the dealer will repair or replace, at ARGO's option, including any related labor costs, all parts that are found to be warrantable and any other parts which the warrantable part caused to be damaged.

It is the owner's responsibility to maintain and service the vehicle in accordance with ARGO's recommendations in the Operator's Manual. To protect yourself and your vehicle, follow all safety and service tips. ARGO will NOT warrant repairs required as a result of not performing standard operator maintenance, storage procedures, and service as outlined in the Operator's Manual.

Should you have any questions concerning the warranty, contact an authorized ARGO dealer.



U.S. EPA & CARB EVAPORATIVE EMISSIONS WARRANTY

ARGO warrants to the purchaser and each subsequent purchaser that the ARGO emissions system is:

- Designed, built and equipped so as to conform with all applicable regulations
- Free from defects in materials and workmanship that cause the failure of a warranted part to be identical in all material respects to that part as described in ARGO's application for certification. The warranty period is limited to 30 months from date of sale.

Subject to certain conditions and exclusions as stated below, the warranty on emission-related parts is as follows:

- Any warranted part that is not scheduled for replacement as required maintenance in the written instructions supplied, is warranted for the warranty period stated above. If the part fails during the period of warranty coverage, the part will be repaired or replaced by ARGO. Any such part repaired or replaced under warranty will be warranted for the remainder of the period.
- Any warranted part that is scheduled only for regular inspection in the written instructions supplied is warranted for the warranty period stated above. Any such part repaired or replaced under warranty will be warranted for the remaining warranty period.
- Any warranted part that is scheduled for replacement as required maintenance in the written instructions supplied is warranted for the period of time before the first scheduled replacement date for that part. If the part fails before the first scheduled replacement, the part will be repaired or replaced. Any such part repaired or replaced under warranty will be warranted for the remainder of the period prior to the first scheduled replacement point for the part.
- Repair or replacement of any warranted part under the warranty provisions herein must be performed at a warranty station at no charge to the owner.
- The Argo owner will not be charged for diagnostic labor that is directly associated with diagnosis of a defective, emission-related warranted part, provided that such diagnostic work is performed at a warranty station.
- ARGO is liable for damages to other engine or equipment components proximately caused by a failure under warranty of any warranted part.
- Throughout the ARGO warranty period stated above, ARGO will maintain a supply of warranted parts sufficient to meet the expected demand for such parts.
- Any replacement part may be used in the performance of any warranty maintenance or repairs and must be provided without charge to the owner. Such use will not reduce the warranty obligations of ARGO.
- Add-on or modified parts that are not exempted by the Air Resources Board may not be used. The use of any non-exempted add-on or modified parts by the purchaser will be grounds for disallowing a warranty claims. ARGO will not be liable to warrant failures of warranted parts caused by the use of a non-exempted add-on or modified part.



U.S. EPA & CARB EVAPORATIVE EMISSIONS WARRANTED PARTS

The repair or replacement of any warranted part otherwise eligible for warranty coverage may be excluded from such warranty coverage if ARGO demonstrates that the XTV has been abused, neglected, or improperly maintained, and that such abuse, neglect, or improper maintenance was the direct cause of the need for repair or replacement of the part. That notwithstanding, any adjustment of a component that has a factory installed, and properly operating, adjustment limiting device is still eligible for warranty coverage.

The following emission warranty parts are covered:

For exhaust emissions, emission-related components include any engine parts related to the following systems:

1. Air-induction system
2. Fuel system
3. Ignition system
4. Exhaust gas recirculation systems

The following parts are also considered emission-related components for exhaust emissions:

1. After treatment devices
2. Crankcase ventilation valves
3. Sensors
4. Electronic control units

The following parts are considered emission-related components for evaporative emissions: (Not Applicable for Diesel Fuel Powered Vehicles)

- | | |
|----------------------------|-------------------------------------|
| 1. Fuel Tank | 10. Vacuum Control Diaphragms* |
| 2. Fuel Cap | 11. Control Cables* |
| 3. Fuel Line | 12. Control Linkages* |
| 4. Fuel Line Fittings | 13. Purge Valves |
| 5. Clamps* | 14. Vapor Hoses† |
| 6. Pressure Relief Valves* | 15. Liquid/Vapor Separator |
| 7. Control Valves* | 16. Carbon Canister† |
| 8. Control Solenoids* | 17. Canister Mounting Brackets |
| 9. Electronic Controls* | 18. Carburetor Purge Port Connector |

*As related to the evaporative emission control system.

†Applicable to California models only

Customer Information / Customer Checklist

Customer Information	
Name	
Address	
City, State, Zip Code	
Phone Number	
FAX	
E-MAIL	

Customer Checklist				
	Yes	No	Initial	Date
Visual Inspection				
Received Service Instructions				
Shown All Engine Controls				
Warranty Fully Explained				
Received Owner's / Engine Manual				
Dealer Demonstrated All Controls				
Received Keys				
I have reviewed and understand the warranty policy				
I have visually inspected the XTV and found no defects				
I understand this XTV is NOT designed for racing				
I understand that this XTV is designed for off-road use only and is NOT intended for use on public roads or highways*				
* Xtreme Terrain Vehicle (XTV) models are for OFF-ROAD USE ONLY. No XTV's are designed for or allowed on highways. Check local laws and ordinances regarding the use of Low-Speed vehicles in your area.				

Pre-Ride Inspection

ITEM	INSPECTION PROCEDURE	ACTION
Engine Oil Level	Add oil if necessary. DO NOT overfill. Replace filler cap securely.	Refer to operator's or engine manual.
Fuel Level	Add fuel (Diesel) if necessary. DO NOT mix oil with diesel. Replace cap securely.	Refer to operator's or engine manual. DO NOT refuel a hot engine. Allow engine to cool before adding fuel.
Warning Decals	Make sure all warning decals are legible and securely attached.	Replace as necessary.
Tires	Prior to operating XTV, check the internal tire pressure and, if necessary, bring the pressure to normal by starting the engine. Carefully inspect tires and wheels and remove foreign objects stuck in them (stones, nails, etc.).	Check the internal pressure measurement with a manometer installed in the cab. Add or remove air as necessary to meet requirements indicated in the specifications section of the Operator's Manual.
Fasteners	Check wheels to ensure that all wheel nuts are securely tightened. Check for missing fasteners. Check that all other fasteners are secure.	Tighten and/or replace fasteners as necessary.
Steering	Make sure steering controls operate-freely.	Lubricate and adjust if necessary
Frame / Chassis	Check for damaged frame and/or other chassis components.	Replace as necessary.
Guards / Shields	Check all guards/shields covering moving parts.	Tighten fasteners on loose guards/shields. Replace worn or damaged.
Lights	Check for proper operation.	See OPERATION section of the Operator's Manual.
Key Switch	Perform switch test and ensure that engine shuts off when key is turned to the "OFF" position.	Repair/replace as necessary
Brakes	Ensure brakes function properly.	Adjust/replace as necessary

ARGO RETAILER - Please complete this page at the time of sale to the new owner so your customer has all pertinent information that may be required.

ARGO MODEL _____

ARGO SERIAL NO. _____

ENGINE SERIAL NO. _____

TRANSMISSION SERIAL NO. _____

SOLD TO: _____

STREET ADDRESS: _____

CITY OR TOWN: _____ PROV/STATE: _____

POSTAL/ZIP: _____

DATE OF SALE: _____

WARRANTY PERIOD EXPIRES: _____

DEALER NAME: _____

PHONE: _____

ADDRESS: _____

CITY/TOWN: _____ PROV/STATE: _____